



Service manual

Europe Series

(DC Inverter 1 Drive 1 50Hz **R32**)

2018.12.29

Contents

Contents	2
Part1 General information	1
1. Nomenclature.....	1
2. Unit appearance.....	2
Part2 Features	4
1. Outdoor Units.....	4
2. Four-way Cassette.....	5
3. Ceiling Floor.....	6
4. Constant Duct.....	7
Part3 Piping System	10
Part4 Specification	11
1. Cassette.....	11
2. Ceiling Floor.....	17
3. Duct.....	23
4. Outdoor Unit.....	29
Part5 Dimension	35
1. Cassette.....	35
2. Ceiling Floor.....	37
3. Duct.....	38
4. Outdoor Unit.....	40
Part6 Electrical Principle Diagram	44
1. Cassette.....	44
2. Ceiling Floor.....	46
3. Duct.....	47
4. Outdoor Unit.....	48
Part7 Capacity Amendment	51
1. Operation range.....	51
2. Capacity amendment of different ambient temperature.....	51
3. Long piping length.....	53
4. Capacity amendment of different piping length.....	54
5. Equivalent Pipe length conversion.....	55
Part8 Static pressure curve	56

R32 High Efficiency DC Inverter LCAC

1. 18K Duct.....	56
2. 24K Duct.....	57
2. 30K Duct.....	58
2. 36K/42K Duct.....	59
3. 48K/60K Duct.....	60
Part9 Control.....	61
1. Controller.....	61
2. Parameters Setting.....	86
3. Room Card Function.....	91
4. Wifi Module.....	94
5. Static Pressure setting.....	97
Part10 Explosive View.....	101
1. Cassette.....	101
2. Ceiling Floor.....	108
3. Duct.....	116
4. Outdoor Unit.....	120
Part11 Installation.....	130
1. Preparation.....	130
2. Precaution.....	131
3. Cassette installation.....	131
4. Ceiling Floor installation.....	137
5. Duct installation.....	139
6. Outdoor Unit installation.....	142
7. Connection piping installation.....	144
8. Emptying or Vacuum.....	147
9. Insulation.....	148
10. Additional refrigerant charge.....	150
11. Electrical connection.....	151
Part12 PCB Instruction.....	155
1. Outdoor Unit PCB.....	155
2. Indoor Unit PCB.....	158
Part13 Trouble Shooting.....	160
1. Failure code display.....	160
2. Failure analysis.....	162

Part1 General information

1. Nomenclature

Indoor Unit

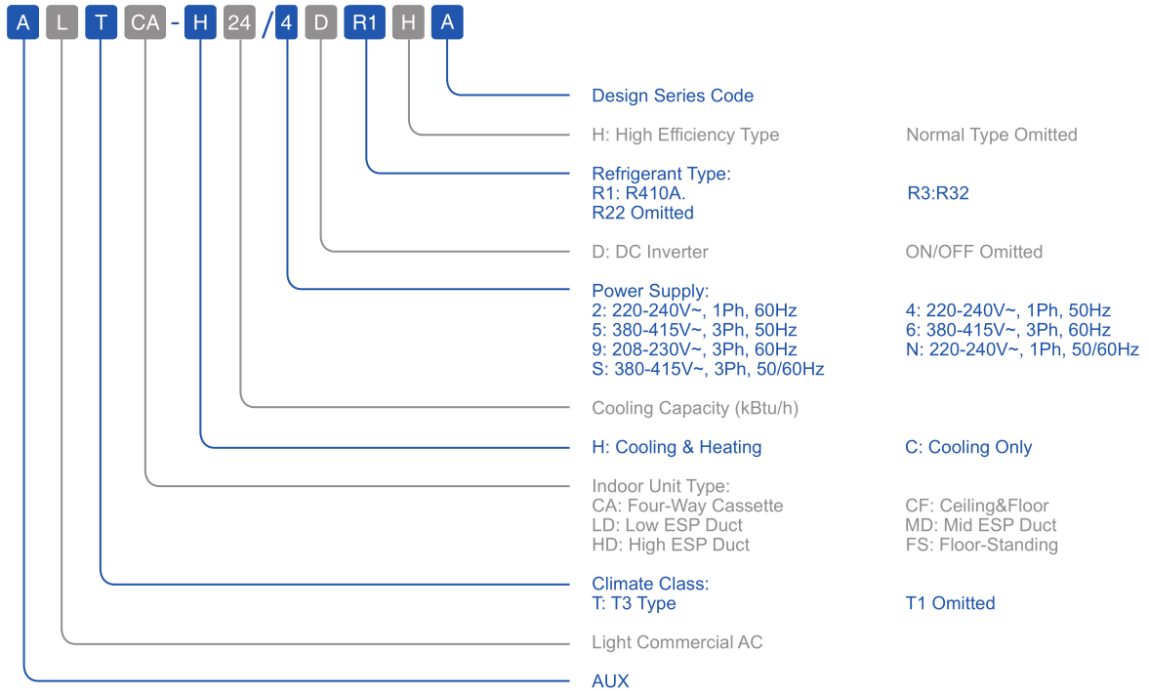



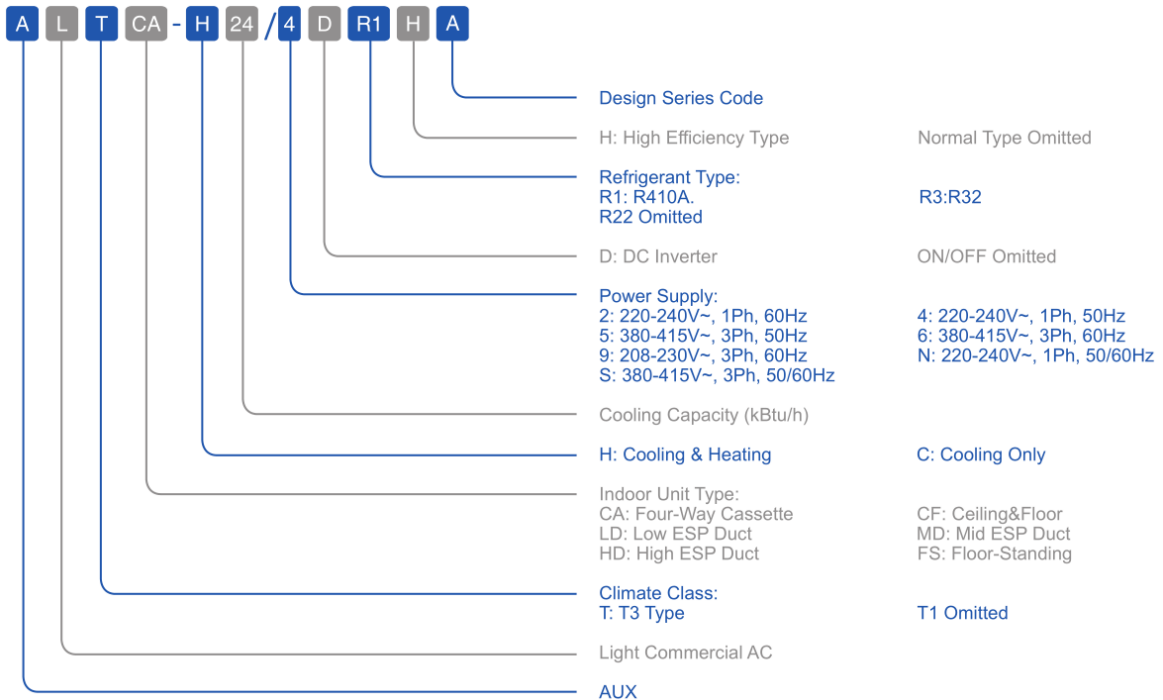



Outdoor Unit



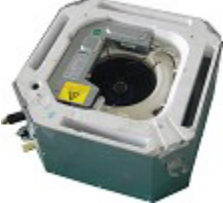

R32 High Efficiency DC Inverter LCAC

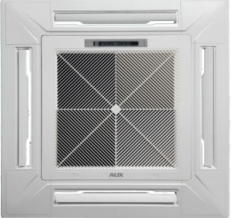
2. Unit appearance

2.1 Cassette

Cassette Body	Model	Panel	
		Standard	Optional
	ALCA-H12/NDR3HAA	 MB13-I	 B09
	ALCA-H18/NDR3HAA		
	ALCA-H24/NDR3HAA	 MB12	 MB08
	ALCA-H36/NDR3HAA		
	ALCA-H42/NDR3HAA		
	ALCA-H48/NDR3HAA		
	ALCA-H60/NDR3HAA		



2.2 Ceiling floor

PICTURE	Capacity	Model
	18k/Btu	ALCF-H18/NDR3HA
	24k/Btu	ALCF-H24/NDR3HA
	36k/Btu	ALCF-H36/NDR3HA
	42k/Btu	ALCF-H42/NDR3HA
	48k/Btu	ALCF-H48/NDR3HA
	60k/Btu	ALCF-H60/NDR3HA





2.3 Duct

PICTURE	Capacity	Model

R32 High Efficiency DC Inverter LCAC

	18k/Btu	ALMD-H18/NDR3HA
	24k/Btu	ALMD-H24/NDR3HA
	30k/Btu	ALMD-H30/NDR3HA
	36k/Btu	ALMD-H36/NDR3HA
	42k/Btu	ALMD-H42/NDR3HA
	48k/Btu	ALMD-H48/NDR3HA
	60k/Btu	ALMD-H60/NDR3HA

2.4 Outdoor Units

Capacity (BTU)	Picture	Capacity (BTU)	Picture
12K、 18K		24K	
30K、 36K、 42k		48K、 60k	 

Part2 Features

1. Outdoor Units

Environmental-friendly Refrigerant R32

The GWP value of R32 is smaller,so the effect on the greenhouse effect is smaller.The ODP value of R32 is 0,so it's no harm to our planet's ozone layer.

High Efficiency

Equipped with high efficiency DC Inverter compressor, adjustable fan motor and advanced 180° sine wave vector driver, the system can be higher than 6.1 in SEER and 4.0 in SCOP so as to meet the European and Australian new energy efficiency standards.

Reliability

Stable cooling under -15°C and heating under -15°C outdoor environment temperature.

180°Sine Wave Control

DC inverter compressor uses 180°sine wave vector control technique, make compressor motor operate smoothly and efficiency increases significantly.

Optimized Pipeline Design

The design ensures the sub-cooling and enhances the cooling capacity by separating the refrigerant inlet and outlet.

Simulation Technology

Via analysing piping stress distribution, piping amplitude and displacement in transportation and operation, the reliability has been improved greatly.

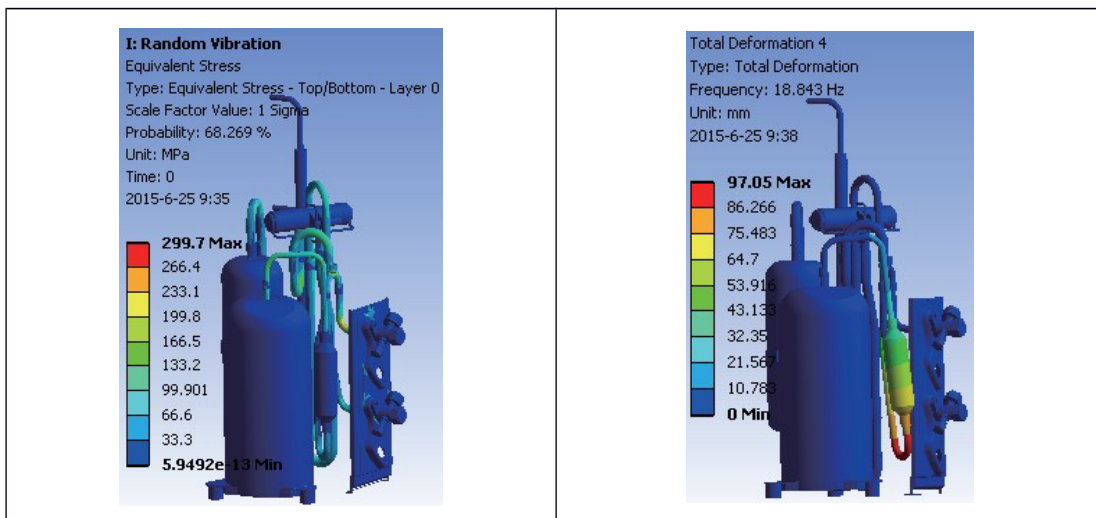

2. Four-way Cassette

Four-way cassette type A/C is installed under the ceiling, compared with Floor & Standing type A/C, it has following advantages: Ceiling installation combining with the decoration, makes the room more elegant; Flexible installation in anywhere in the ceiling and 4-direction blowing, makes you feel more comfortable.

Built-in Drain Pump

The built-in drain pump can lift condensing water up to 1200mm high from the drainage pan.

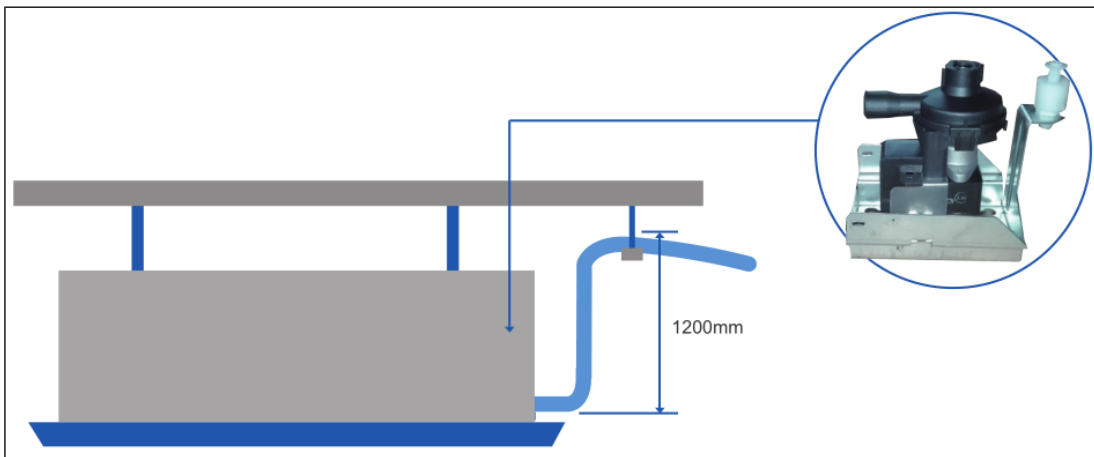

Fresh Air Intake

Fresh air makes indoor air healthy and comfortable.

Optimized Electric Box

Better fire-proof and easy to maintenance.

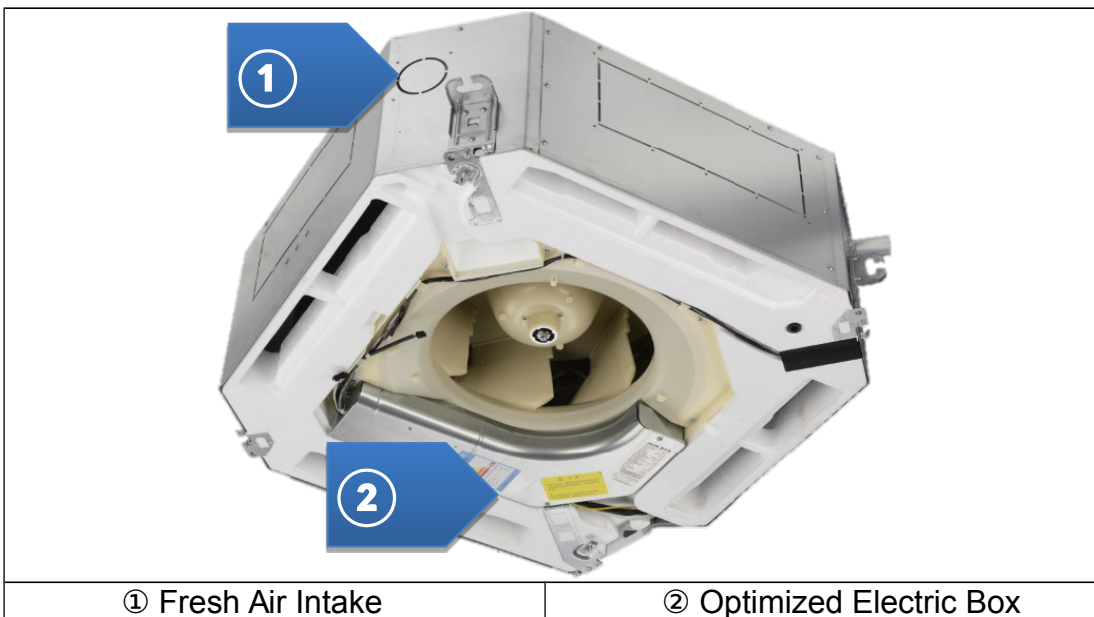

3. Ceiling Floor

Ceiling & Floor type A/C can be installed under the ceiling and also on the floor. Compared with normal Floor & Standing type A/C, it can be hoisted under the ceiling, saving room space, it is also the updating Product for Floor & Standing type A/C.

3D Air Swing

Vertical and horizontal swing makes air below to every corner of the room.

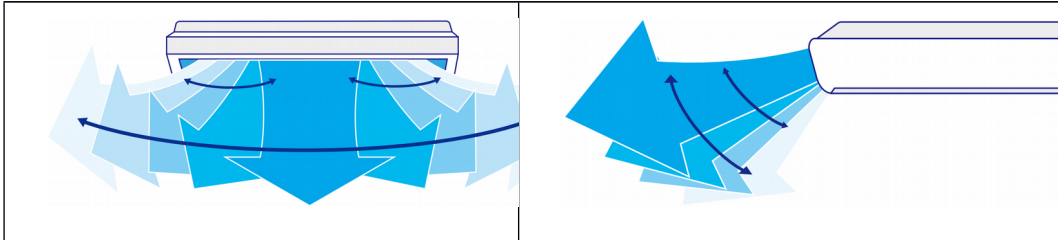

Ultra Slim Design

The thickness is only 205mm, save installation space.



Innovative Centrifugal Fan

Innovative centrifugal fan provides larger air volume but lower noise, making the air supply more quietly and smoothly.

Flexible Installation

Can be vertically installed against the wall or horizontally installed under the ceiling.



4. Constant Duct

Constant Air Flow Volume

Under different ESP, the product supply Constant air flow volume for comfort.

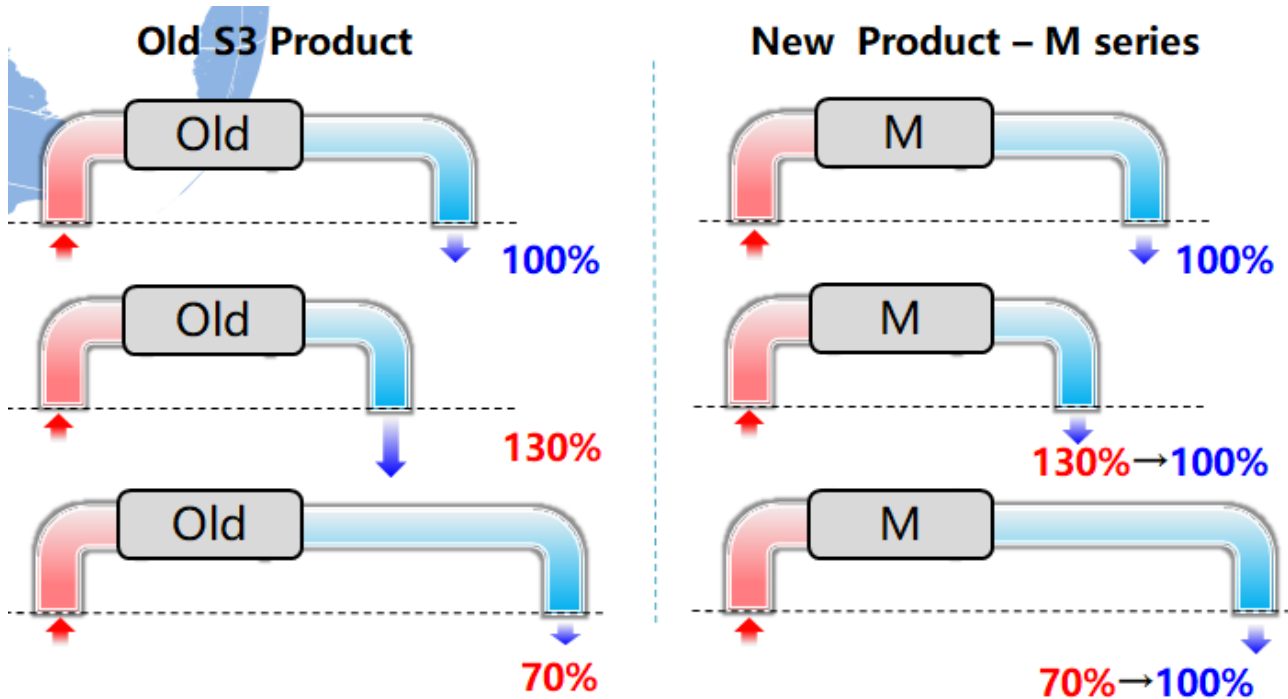

Integrate the control board and power board

High reliability

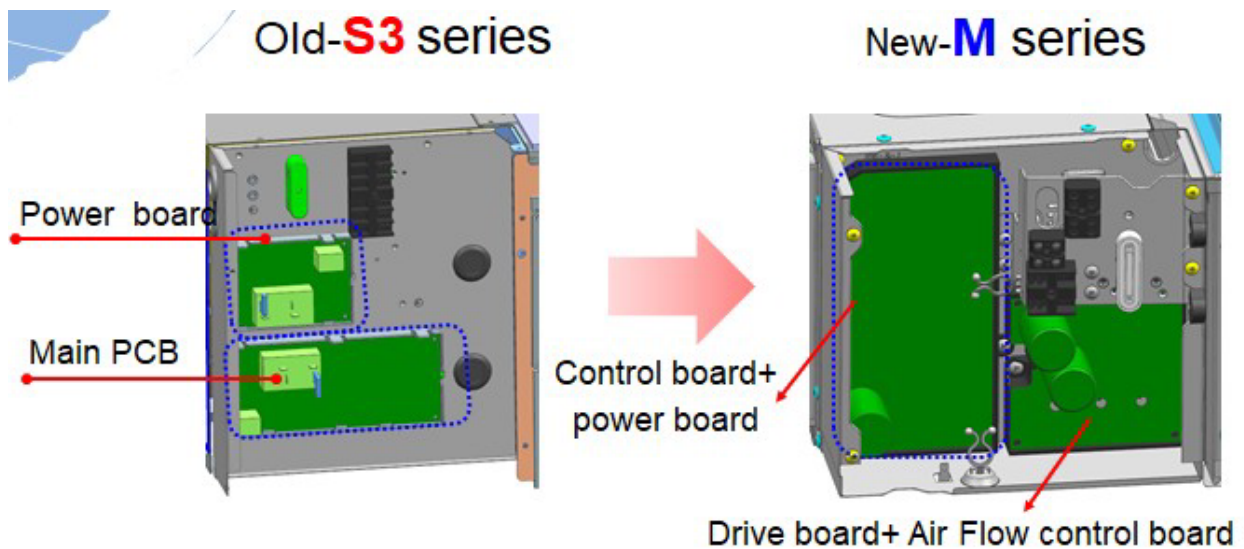

Two-way drain pan

Daikin Drain Pan
plastic suction, 1 way



Old product Drain Pan
printed steel, 1 way

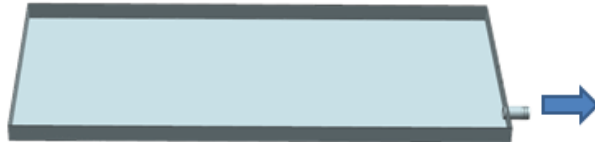

New Drain Pan
plastic suction, 2 way,
Convenient for installation

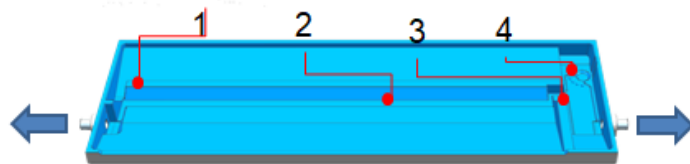

4-step Drain Pan (same as Daikin)
Less storage water

Independently designed bottom flange

Independently designed bottom flange, The air duct will not be damaged in maintenance

Easy for maintenance

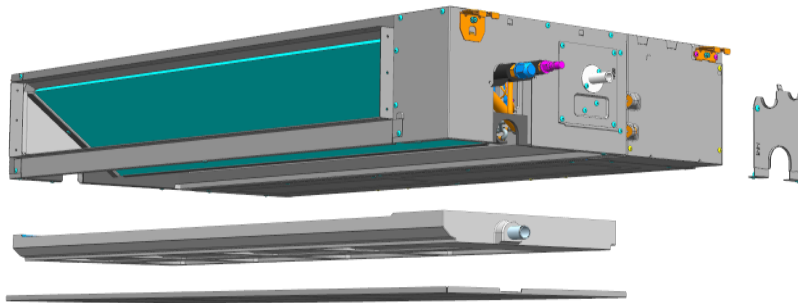

Easy disassembly filter

0 Screws, Easy disassembly, convenient for wash, W type high efficiency filter

R32 High Efficiency DC Inverter LCAC



R32 High Efficiency DC Inverter LCAC
Optimized Centrifugal Fan

Old Fan

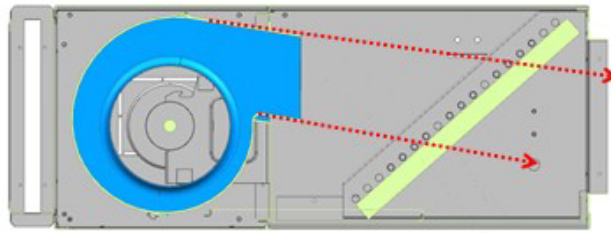

New Fan

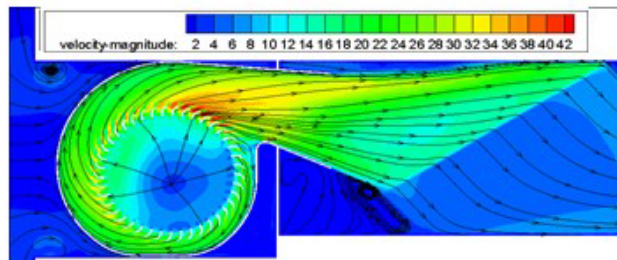
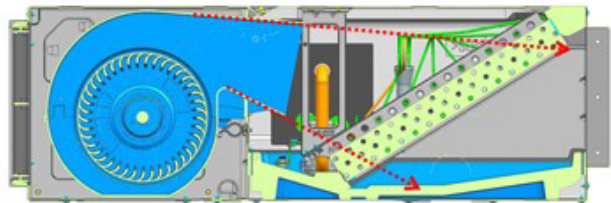

Removable Control Box

Daikin product



Non-removable

Old-S3 series

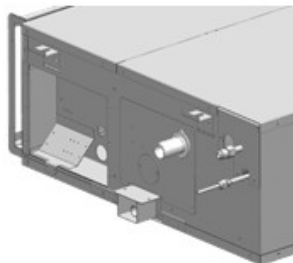

Not easy for remove

New product M series

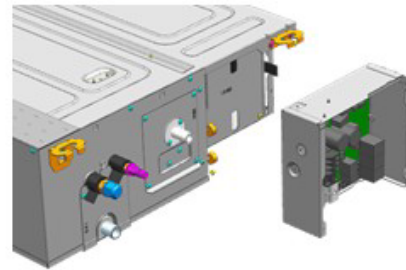

2 Screws, easy for remove
 Easy for maintenance

Part3 Piping System

The compressor inhales the low-temperature and low-pressure refrigerant vapor from the evaporator, and vapor be turned into high-temperature and high-pressure gas then enters into condenser, the high-temperature and high-pressure refrigerant gas and outdoor air make heat exchange in the condenser, the compressed vapor is then cooled by heat exchange with the outside air, so that the vapor condenses to be a high-temperature and high-pressure fluid, and then through capillary throttling to cooled, low pressure, then the liquid enters into the evaporator and two-phase of gas and liquid refrigerant in the evaporator completely evaporate, thereby cooling the indoor air; from evaporator the vapor is inhaled into compressor again, so it runs continuously cycle to cycle, cooled air is continuous supplied to the air-conditioned area though duct by fan motor.

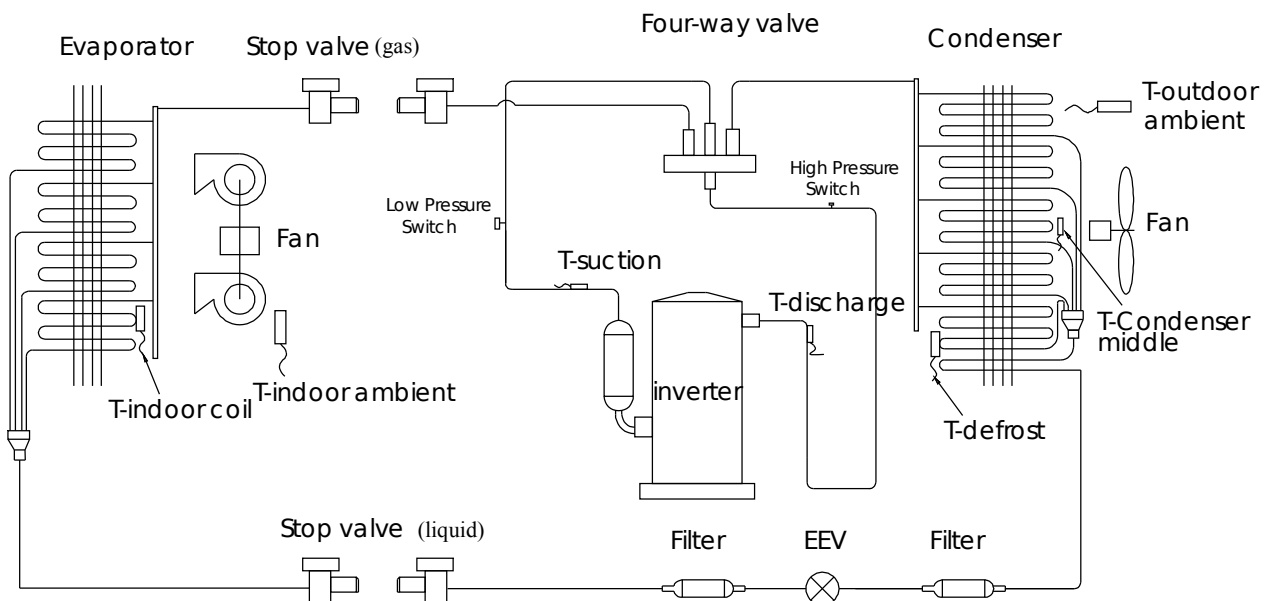

Part4 Specification

1. Cassette

1.1 12K, 18K , 24K, 36K ,

Model	Indoor		ALCA-H12/NDR3HA A ALCA-H12/NDR3HA B	ALCA-H18/NDR3HA A ALCA-H18/NDR3HA B	ALCA-H24/NDR3HA A ALCA-H24/NDR3HA B	ALCA-H36/NDR3HAA ALCA-H36/NDR3HAB
	Panel		MB09 MB13	MB09 MB13	MB08 MB12	MB08 MB12
	Outdoor		AL-H12/NDR3A(U))	AL-H18/NDR3A(U))	AL-H24/NDR3A(U))	AL-H36/NDR3A(U)
Factory Model	Indoor		ALCA-H12A4/R3VDS 1-C2	ALCA-H18A4/R3VDS 1-C2	ALCA-H24A4/R3VDS 1-C2	ALCA-H36A4E5/R3VD S1-C2
	Outdoor		AL-H12A4/R3VDS 1-C2	AL-H18A4/R3VDS 1-C2	AL-H24A4/R3VDS 1-C2	AL-H36A4/R3VDS1- C2
Power Supply		V~, Hz, P h	220-240/50/1	220-240/50/1	220-240/50/1	220-240/50/1
Capacity	Cooling	Btu/h	12000(4600-15000)	18000(5200-19100)	24000(7400-28000)	36000 (9800-44300)
		KW	3.60(1.35-4.40)	5.00(1.53-5.60)	7.00(2.16-8.20)	10.55 (2.9-13)
	Heating	Btu/h	14300(4200-18100)	19100(4800-21200)	27300(6800-31700)	38000 (8800-46000)
		KW	4.20(1.24-5.30)	5.60(1.40-6.20)	8.00(1.98-9.30)	11.15 (2.6-13.5)
Electric Data	Rated Cooling Power Input	KW	1.08(0.26 ~ 1.60)	1.63(0.47 ~ 2.30)	2.18(0.67-3.56)	3.4 (0.71-4.71)
	Rated Heating Power Input	KW	1.23(0.19 ~ 1.51)	1.73(0.46 ~ 2.25)	2.10(0.65-3.62)	3.45 (0.47-4.13)
	Rated Cooling Current	A	4.74(1.1 ~ 5.76)	7.16(2.25 ~ 10.10)	9.57 (3.21-15.63)	15 (3.2-21.5)
	Rated Heating Current	A	5.40(0.78 ~ 6.6)	7.60(2.20 ~ 9.88)	9.22 (3.11-15.90)	15.5 (2.43-18)
Performance	EER/COP	W/W	3.33/3.41	3.07/3.24	3.21/3.81	3.10/3.23
	SEER/SCOP	W/W	6.2/4.1	6.3/4.0	6.5/4.2	6.1/4.0
Indoor Fan Motor	Model		XD30C-ZL	XD30C-ZL	XD50B-ZL	XD100A-ZL
	Brand		Panasonic	Panasonic	Panasonic	Panasonic
	Output Power x Fan quantity	W	30×1	30×1	50×1	100*1
	Capacitor	uF	/	/	/	/

R32 High Efficiency DC Inverter LCAC

	Speed (Hi/Mi/Lo)	r/min	750/700/650	750/700/650	530/470/420	700/600/550
Indoor Coil	a.Number Of Row		2	2	2	2
	b.Tube Pitch(a)x Row Pitch(b)	mm	20.5×12.7	20.5×12.7	16.32×12.7	16.32×12.7
	c.Fin Pitch	mm	1.5	1.5	1.6	1.4
	d.Fin Material		Hydrophilic aluminum fin	Hydrophilic aluminum fin	Hydrophilic aluminum fin	Hydrophilic aluminum fin
	e.Tube Outside Dia.and Material	mm	φ7 , Inner grooved	φ7 , Inner grooved	φ7 , Inner grooved	φ7 , Inner grooved
	f.Coil Length x Height x Width	mm	1322×205×25.4	1322×205×25.4	2044×205×25.4	2074×494×25.4
	g.Heat Exchanging Area	m ²	5.76	6.12	12.7	11.63
Indoor Unit	Indoor Air Flow (Hi/Mi/Lo)	m ³ /h	700/600/530	700/600/530	1300/1050/950	1800/1550/1350
	Sound Pressure Noise Level (Hi/Mi/Lo)	dB(A)	45/44/36	45/44/36	47/43/38	51/48/45
	Sound Power Noise Level	dB(A)	56	56	57	62
	Net Dimension (W*H*D)	mm	570×570×260	570×570×260	835×835×250	835×835×290
	Packing Dimension (W*H*D)	mm	655×655×295	655×655×295	910×910×310	910×910×350
	Net Weight	Kg	17	17	24	26.5
	Gross Weight	Kg	20	20	27.5	30.5
Panel	Net Dimension (W*H*D)	mm	650×650×55	650×650×55	950×950×55	950×950×55
	Packing Dimension (W*H*D)	mm	710×710×80	710×710×80	1000×1000×100	1000×1000×100
	Net weight	Kg	2.2	2.2	5.3	5.3
	Gross weight	Kg	3.7	3.7	7.8	7.8
Refrigerant Pipe	Liquid Side	mm	6.35(1/4)	6.35(1/4)	9.52(3/8)	9.52
	Gas Side	mm	12.7(1/2)	12.7(1/2)	15.88(5/8)	15.88
	Drainage	mm	R3/4in(DN20)	R3/4in(DN20)	R3/4in(DN20)	R3/4in (DN20)
	Max. Refrigerant Pipe Length	m	25	30	50	65
	Max. Difference In Level	m	10	20	25	30
Operation Temperature	°C	16~32	16~32	16~32	16~32	

R32 High Efficiency DC Inverter LCAC

Range						
Ambient Temperature Range(Cooling/Heating)		°C	-15~52/-15~24	-15~52/-15~24	-15~52/-15~24	-15~52/-15~24
Connection Wiring	Power Wiring(Indoor)	mm ²	3*1.5	3*1.5	3*1.5	3*1.5
	Power Wiring(Outdoor)	mm ²	5*2.5	5*2.5	5*2.5	5*2.5
	Signal Wiring	mm ²	2*0.2	2*0.2	2*0.2	2*0.2
Wireless Remote Controller			YKR-L/300-HYE	YKR-L/300-HYE	YKR-L/300-HYE	YKR-L/300-HYE
Qty'per 20'& 40'&40HQ(Only For Reference)		Set	66/139/165	66/139/165	36/76/86	27/62/66

R32 High Efficiency DC Inverter LCAC

1.2 42K, 48K , 60K

Model	Indoor		ALCA- H42/NDR3HAA ALCA- H42/NDR3HAB	ALCA- H48/SDR3HAA ALCA- H48/SDR3HAB	ALCA- H60/SDR3HAA ALCA- H60/SDR3HAB
	Panel		MB08 MB12	MB08 MB12	MB08 MB12
	Outdoor		AL-H42/NDR3A(U)	AL-H48/SDR3A(U)	AL-H60/SDR3A(U)
Factory Model	Indoor		ALCA- H42A4E5/R3VDS1- C2	ALCA- H48A5E5/R3VDS1- C2	ALCA- H60A5E5/R3VDS1- C2
	Outdoor		AL- H42A4/R3VDS1-C2	AL- H48A5/R3VDS1-C2	AL- H60A5/R3VDS1-C2
Power Supply		V~,Hz ,Ph	220-240/50/1	380-415/50/3	380-415/50/3
Capacity	Cooling	Btu/h	42000(9800-46000)	48000(16241- 56298)	55000(16241- 59710)
		KW	12.1(2.9-13.5)	14.00(4.76-16.5)	16.00(4.76-17.5)
	Heating	Btu/h	46000 (8800- 51100)	55000(16309- 55104)	58000(16308- 63122)
		KW	13.5 (2.6-15)	16.00(4.78-16.15)	17.00(4.78-18.50)
Electric Data	Rated Cooling Power Input	KW	4.5 (0.71-5.1)	5.20 (1.71-6.7)	6.10 (1.71-6.8)
	Rated Heating Power Input	KW	4.6 (0.47-4.53)	5.40 (1.71-6.8)	5.80 (1.71-7.1)
	Rated Cooling Current	A	19.5 (3.2-22.3)	7.53(2.47~9.53)	8.83(2.47~9.7)
	Rated Heating Current	A	20 (2.43-19.7)	7.80(2.47~9.70)	8.40(2.47~9.83)
Performance	EER/COP	W/W	2.69/2.93	2.69/2.96	2.62/2.93
	SEER/SCOP	W/W	6.1/4.0	6.1/4.0	6.1/4.0
Indoor Fan Motor	Model		XD100A-ZL	XD100A-ZL	XD100A-ZL
	Brand		Panasonic	Panasonic	Panasonic
	Output Power x Fan quantity	W	100*1	100*1	100*1
	Capacitor	uF	/	/	/
	Speed (Hi/Mi/Lo)	r/min	700/600/550	700/600/550	700/600/550
Indoor Coil	a.Number Of Row		2	3	3
	b.Tube Pitch(a)x Row Pitch(b)	mm	16.32×12.7	20.5×12.7	20.5×12.7
	c.Fin Pitch	mm	1.4	1.5	1.5
	d.Fin Material		Hydrophilic aluminum fin	Hydrophilic aluminum fin	Hydrophilic aluminum fin

R32 High Efficiency DC Inverter LCAC

	e.Tube Outside Dia.and Material	mm	φ7 , Inner grooved	φ7 , Inner grooved	φ7 , Inner grooved
	f.Coil Length x Height x Width	mm	2074×494×25.4	2074×248×38.1	2074×248×38.1
	g.Heat Exchangin g Area	m ²	11.63	17.44	17.44
Indoor Unit	Indoor Air Flow (Hi/Mi/Lo)	m ³ /h	1800/1550/1350	1950/1750/1500	1950/1750/1500
	Sound Pressure Noise Level (Hi/Mi/Lo)	dB(A)	51/48/45	52/50/48	52/50/48
	Sound Power Noise Level	dB(A)	62	65	65
	Net Dimension (W*H*D)	mm	835×835×290	835×835×290	835×835×290
	Packing Dimension (W*H*D)	mm	910×910×350	910×910×350	910×910×350
	Net Weight	Kg	26.5	31	31
	Gross Weight	Kg	30.5	35	35
Panel	Net Dimension (W*H*D)	mm	950×950×55	950×950×55	950×950×55
	Packing Dimension (W*H*D)	mm	1000×1000×100	1000×1000×100	1000×1000×100
	Net weight	Kg	5.3	5.3	5.3
	Gross weight	Kg	7.8	7.8	7.8
Refrigerant Pipe	Liquid Side	mm	9.52	9.52	9.52
	Gas Side	mm	15.88	19.05	19.05
	Drainage	mm	R3/4in (DN20)	R3/4in (DN20)	R3/4in (DN20)
	Max. Refrigerant Pipe Length	m	65	65	65
	Max. Difference In Level	m	30	30	30
Operation Temperature Range		°C	16~32	16~32	16~32
Ambient Temperature Range(Cooling/ Heating)		°C	-15~52/-15~24	-15~52/-15~24	-15~52/-15~24

R32 High Efficiency DC Inverter LCAC

Connection Wiring	Power Wiring(Indoor)	mm ²	3*1.5	3*1.5	3*1.5
	Power Wiring(Outdoor)	mm ²	5*2.5	5*2.5	5*2.5
	Signal Wiring	mm ²	2*0.2	2*0.2	2*0.2
Wireless Remote Controller			YKR-L/300-HYE	YKR-L/300-HYE	YKR-L/300-HYE
Qty'per 20'& 40'&40HQ(Only For Reference)		Set	27/62/66	22/50/54	22/50/54

2. Ceiling Floor

2.1 18K, 24K, 36K

Model	Indoor		ALCF-H18/NDR3HA	ALCF-H24/NDR3HA	ALCF-H36/NDR3HA
	Outdoor		AL-H18/NDR3A(U)	AL-H24/NDR3A(U)	AL-H36/NDR3A(U)
Factory Model	Indoor		ALCF-H18A4/R3VDS1-C2	ALCF-H24A4/R3VDS1-C2	ALCF-H36A4C5/R3VDS1-C2
	Outdoor		AL-H18A4/R3VDS1-C2	AL-H24A4/R3VDS1-C2	AL-H36A4/R3VDS1-C2
Power Supply		V~,Hz, Ph	220-240/50/1	220-240/50/1	220-240/50/1
Capacity	Cooling	Btu/h	18000(5200-19100)	24000(7400-28000)	36000 (9800-44300)
		KW	5.00(1.53-5.60)	7.00(2.16-8.20)	10.55 (2.9-13)
	Heating	Btu/h	19100(4800-21200)	27300(6800-31700)	38000 (8800-46000)
		KW	5.60(1.40-6.20)	8.00(1.98-9.30)	11.15 (2.6-13.5)
Electric Data	Rated Cooling Power Input	W	1.63(0.47 ~ 2.30)	2.25(0.67-3.56)	3.4 (0.71-4.71)
	Rated Heating Power Input	W	1.73(0.46 ~ 2.25)	2.10(0.65-3.62)	3.45 (0.47-4.13)
	Rated Cooling Current	A	7.16(2.25 ~ 10.10)	9.88 (3.21-15.63)	15 (3.2-21.5)
	Rated Heating Current	A	7.60(2.20 ~ 9.88)	9.60 (3.11-15.90)	15.5 (2.43-18)
Performance	EER/COP	W/W	3.07/3.24	3.11/3.81	3.09/3.23
	SEER/SCOP	W/W	6.1/4.1	6.3/4.1	6.1/4.0
Indoor Fan Fotor	Model		FP40A-ZL	FP90A-ZL	FP110A-ZL
	Brand		Panasonic	Panasonic	Panasonic
	Output Power x Fan quantity	W	40×1	90×1	110×1
	Capacitor	uF	/	/	/
	Speed (Hi/Mi/Lo)	r/min	1300/1100/1000	1300/1100/1000	1350/1250/1100
Indoor Coil	a.Number Of Row		3	3	3
	b.Tube Pitch(a)x Row Pitch(b)	mm	20.5×12.7	20.5×12.7	22×19.05
	c.Fin Spacing	mm	1.6	1.6	1.6
	d.Fin Material		Hydrophilic aluminum fin	Hydrophilic aluminum fin	Hydrophilic aluminum fin
	e.Tube Outside	mm	φ7 , Inner grooved	φ7 , Inner grooved	φ7.94 , Inner grooved

R32 High Efficiency DC Inverter LCAC

	Dia.and Material				
	f.Coil Length x Height x Width	mm	599×246×38.1	950×246×38.1	1300×242×57.15
	g.Heat Exchanging Area	m ²	6.3	10	20.54
Indoor Unit	Indoor Air Flow (Hi/Mi/Lo)	m ³ /h	900/730/650	1300/1052/920	1800/1550/1350
	Sound Pressure Noise Level (Hi/Mi/Lo)	dB(A)	45/40/34	47/43/38	53/50/47
	Sound Power Noise Level	dB(A)	56	57	63
	Net Dimension (W*H*D)	mm	929×660×205	1280×660×205	1631×660×205
	Packing Dimension (W*H*D)	mm	1010×720×290	1360×720×290	1710×720×290
	Net Weight	Kg	25	32	44
	Gross Weight	Kg	28	38	50
Refrigerant Pipe	Liquid Side	mm	6.35(1/4)	9.52(3/8)	9.52
	Gas Side	mm	12.7(1/2)	15.88(5/8)	15.88
	Drainage	mm	R3/4in(DN20)	R3/4in(DN20)	R3/4in(DN20)
	Max. Refrigerant Pipe Length	m	30	50	65
	Max. Difference In Level	m	20	25	30
Operation Temperature Range		°C	16~32	16~32	16~32
Ambient Temperature Range(Cooling/Heating)		°C	-15~52/-15~24	-15~52/-15~24	-15~52/-15~24
Connection Wiring	Power Wiring(Indoor)	mm ²	3*1.5	3*1.5	3*1.5
	Power Wiring(Outdoor)	mm ²	5*2.5	5*2.5	5*2.5
	Signal Wiring	mm ²	2*0.2	2*0.2	2*0.2
Wireless Remote Controller			YKR-L/300-HYE	YKR-L/300-HYE	YKR-L/300-HYE
Qty'per 20'& 40'&40HQ(Only For Reference)		Set	57/123/149	48/92/102	32/70/81

R32 High Efficiency DC Inverter LCAC

2.2 42K, 48K, 60K

Model	Indoor		ALCF-H42/NDR3HA	ALCF-H48/SDR3HA	ALCF-H60SDR3HA
	Outdoor		AL-H42/NDR3A(U)	AL-H48/SDR3A(U)	AL-H60/SDR3A(U)
Factory Model	Indoor		ALCF-H42A4C5/R3VDS1-C2	ALCF-H48A5C5/R3VDS1-C2	ALCF-H60A5C5/R3VDS1-C2
	Outdoor		AL-H42A4/R3VDS1-C2	AL-H48A5/R3VDS1-C2	AL-H60A5/R3VDS1-C2
Power Supply		V~,Hz, Ph	220-240/50/1	380-415/50/3	380-415/50/3
Capacity	Cooling	Btu/h	42000(9800-46000)	48000(16241-56298)	55000(16241-59710)
		KW	12.1(2.9-13.5)	14.00(4.76-16.50)	16.00(4.76-17.5)
	Heating	Btu/h	46000 (8800-51100)	55000(16309-55104)	58000(16308-63122)
		KW	13.5 (2.6-15)	16.00(4.78-16.15)	17.00(4.78-18.50)
Electric Data	Rated Cooling Power Input	W	4.5 (0.71-5.1)	5.3 (1.71-6.7)	6.11 (1.71-6.8)
	Rated Heating Power Input	W	4.6 (0.47-4.53)	5.5 (1.71-6.8)	5.90 (1.71-7.1)
	Rated Cooling Current	A	19.5 (3.2-22.3)	7.67(2.47~9.53)	8.83(2.47~9.70)
	Rated Heating Current	A	20 (2.43-19.7)	7.97(2.47~9.70)	8.53(2.47~9.83)
Performance	EER/COP	W/W	2.69 /2.93	2.64/2.91	2.62/2.88
	SEER/SCOP	W/W	6.1/4.0	6.1/4.0	6.1/4.0
Indoor Fan Fotor	Model		FP110A-ZL	FP110A-ZL	FP110A-ZL
	Brand		Panasonic	Panasonic	Panasonic
	Output Power x Fan quantity	W	110×1	110×1	110×1
	Capacitor	uF	/	/	/
	Speed (Hi/Mi/Lo)	r/min	1350/1250/1100	1350/1250/1100	1350/1250/1100
Indoor Coil	a.Number Of Row		3	3	3
	b.Tube Pitch(a)x Row Pitch(b)	mm	22×19.05	22×19.05	22×19.05
	c.Fin Spacing	mm	1.6	1.6	1.6
	d.Fin Material		Hydrophilic aluminum fin	Hydrophilic aluminum fin	Hydrophilic aluminum fin
	e.Tube Outside Dia.and Material	mm	φ7.94 , Inner grooved	φ7.94 , Inner grooved	φ7.94 , Inner grooved
	f.Coil Length x	mm	1300*242*57.15	1300*242*57.15	1300*242*57.15

R32 High Efficiency DC Inverter LCAC

	Height x Width				
	g.Heat Exchanging Area	m ²	20.54	20.54	20.54
Indoor Unit	Indoor Air Flow (Hi/Mi/Lo)	m ³ /h	1800/1550/1350	1900/1600/1400	1900/1600/1400
	Sound Pressure Noise Level (Hi/Mi/Lo)	dB(A)	53/50/47	53/51/49	53/51/49
	Sound Power Noise Level	dB(A)	63	64	64
	Net Dimension (W*H*D)	mm	1631x660x205	1631x660x205	1631x660x205
	Packing Dimension (W*H*D)	mm	1710x720x290	1710x720x290	1710x720x290
	Net Weight	Kg	44	44	44
	Gross Weight	Kg	50	50	50
Refrigerant Pipe	Liquid Side	mm	9.52	9.52	9.52
	Gas Side	mm	15.88(5/8)	19.05	19.05
	Drainage	mm	R3/4in(DN20)	R3/4in(DN20)	R3/4in(DN20)
	Max. Refrigerant Pipe Length	m	65	65	65
	Max. Difference In Level	m	30	30	30
Operation Temperature Range		°C	16~32	16~32	16~32
Ambient Temperature Range(Cooling/Heating)		°C	-15~52/-15~24	-15~52/-15~24	-15~52/-15~24
Connection Wiring	Power Wiring(Indoor)	mm ²	3*1.5	3*1.5	3*1.5
	Power Wiring(Outdoor)	mm ²	5*2.5	5*2.5	5*2.5
	Signal Wiring	mm ²	2*0.2	2*0.2	2*0.2
Wireless Remote Controller			YKR-L/300-HYE	YKR-L/300-HYE	YKR-L/300-HYE
Qty'per 20'& 40'&40HQ(Only For Reference)		Set	32/70/81	24/54/54	24/54/54

3. Duct

3.1 18K, 24K,30K, 36K

Model	Indoor		ALMD-H18/NDR 3HA	ALMD-H24/NDR 3HA	ALMD-H30/NDR 3HA	ALMD-H36/NDR 3HA
	Outdoor		AL-H18/NDR 3A(U)	AL-H24/NDR 3A(U)	AL-H30/NDR 3A(U)	AL-H36/NDR 3A(U)
Factory Model	Indoor		ALMD-H18A4M3 /R3VDS1-C2	ALMD-H24A4M3 /R3VDS1-C2	ALMD-H30A4M3 /R3VDS1-C2	ALMD-H36A4M4 /R3VDS1-C2
	Outdoor		AL-H18A4/R 3VDS1-C2	AL-H24A4/R 3VDS1-C2	AL-H30A4/R 3VDS1-C2	AL-H36A4/R 3VDS1-C2
Power Supply		V ~, Hz, Ph	220-240/50/1	220-240/50/1	220-240/50/1	220-240/50/1
Capacity	Cooling	Btu/h	18000(5200 -19100)	24000(7400-28000)	28660 (8490~31390)	36000 (9800-44300)
		KW	5.00 (1.53-5.60)	7.00(2.16-8.20)	8.40 (2.49-9.20)	10.55 (2.9-13)
	Heating	Btu/h	19100(4800-21200)	27300(6800- 31700)	30700(9760~32760)	38000 (8800-46000)
		KW	5.60 (1.40-6.20)	8.00(1.98-9.30)	9.00 (2.86-9.60)	11.15 (2.6-13.5)
Electric Data	Rated Cooling Power Input	W	1.55 (0.47-2.30)	2.12 (0.67-3.56)	3.09 (0.71-3.70)	3.4 (0.71-4.71)
	Rated Heating Power Input	W	1.49 (0.46-2.25)	2.12 (0.65-3.62)	2.86 (0.67-3.70)	3.45 (0.47-4.13)
	Rated Cooling Current	A	6.73 (2.25-10.10)	9.22 (3.21-15.63)	13.43 (3.09-16.25)	15 (3.2-21.5)
	Rated Heating Current	A	6.8 (2.20-9.88)	9.6 (3.11-15.90)	12.50 (2.91-16.25)	15.5 (2.43-18)

R32 High Efficiency DC Inverter LCAC

	ent					
Per for ma nc e	EER /CO P	W / W	3.23/3.76	3.30/3.77	2.72/3.15	3.10/3.23
	SEE R/S COP	W / W	6.2/4.0	6.1/4.0	6.1/4.1	6.1/4.1
Ind oor Fa n Fot or	Mod el		FP200B- ZL	FP200B- ZL	FP200B- ZL	FP300B- ZL
	Br an d		dayang	dayang	dayang	weiling
	Out p u t P ow er x F an q uan t ity	W	200×1	200×1	200×1	300×1
	Cap ac ito r	u F	/	/	/	/
	Spe ed (Hi/ Mi/L o)	r/ m in	1020/915/ 855	1200/106 5/960	1350/124 5/1110	1185/109 5/1020
Ind oor Coi l	a.Nu mbe r Of Row		2	3	3	3
	b.Tu be Pitch (a)x Row Pitch (b)	m m	20.5×12.7	20.5×12.7	20.5×12.7	20.5×12.7
	c.Fin Spa cing	m m	1.5	1.5	1.5	1.5
	d.Fin Mate rial		Hydrophili c aluminum fin	Hydrophili c aluminum fin	Hydrophili c aluminum fin	Hydrophili c aluminum fin
	e.Tu be Outs ide Dia. and Mate rial	m m	φ7 , Inner grooved	φ7 , Inner grooved	φ7 , Inner grooved	φ7 , Inner grooved
	f.Coi l Leng th x Heig ht x Widt	m m	811*328* 25.4	811*328* 38.1	811*328* 38.1	1211*328 *38.1

R32 High Efficiency DC Inverter LCAC

	h						
	g.Heat Exchanging Area	m ²	8.05	12.08	12.08	18.03	
Indoor Unit	Indoor Air Flow (Hi/Mi/Lo)	m ³ /h	1150/960/840	1400/1190/980	1600/1400/1100	1900/1600/1400	
	Sound Pressure Noise Level (Hi/Mi/Lo)	dB(A)	43/41/40	44/41/39	46/44/41	44/41/39	
	Sound Power Noise Level	dB(A)	53	55	57	55	
	Net Dimension (W*H*D)	mm	1000x700x245	1000x700x245	1000x700x245	1400x700x245	
	Packing Dimension (W*H*D)	mm	1230x830x300	1230x830x300	1230x830x300	1630x830x300	
	Net Weight	Kg	31	32	32	42	
	Gross Weight	Kg	37	38	38	48	
	ESP	Pa	25(0~160)	25(0~160)	37(0~160)	37(0~160)	
	Refrigerant	Liquid Side	mm	6.35(1/4)	9.52(3/8)	9.52(3/8)	9.52(3/8)
		Gas	m	12.7(1/2)	15.88(5/8)	15.88(5/8)	15.88(5/8)

R32 High Efficiency DC Inverter LCAC

Pipe	Side	m				
	Drainage	m	R3/4in(D N20)	R3/4in(D N20)	R3/4in(D N20)	R3/4in(D N20)
	Max. Refrigerant Pipe Length	m	30	50	50	65
	Max. Difference In Level	m	20	25	25	30
Operation Temperature Range		°C	16~32	16~32	16~32	16~32
Ambient Temperature Range(Cooling/Heating)		°C	-15~52/-15~24	-15~52/-15~24	-15~52/-15~24	-15~52/-15~24
Connection Wiring	Power Wiring(Indoor)	m ²	3*1.5	3*1.5	3*1.5	3*1.5
	Power Wiring(Outdoor)	m ²	5*2.5	5*2.5	5*2.5	5*2.5
	Signal Wiring	m ²	2*0.2	2*0.2	2*0.2	2*0.2
Wireless Remote Controller			/	/	/	/
Qty'per 20'& 40'&40HQ (Only For Reference)		Set	46/97/112	42/89/99	32/64/83	27/56/69

R32 High Efficiency DC Inverter LCAC

2.2 42K, 48K,60K

Model	Indoor		ALMD-H42/NDR3HA	ALMD-H48/SDR3HA	ALMD-H60/SDR3HA
	Outdoor		AL-H42/NDR3A(U)	AL-H48/SDR3A(U)	AL-H60/SDR3A(U)
Factory Model	Indoor		ALMD-H42A4M4/R3VDS1-C2	ALMD-H48A5E5/R3VDS1-C2	ALMD-H60A5E5/R3VDS1-C2
	Outdoor		AL-H42A4/R3VDS1-C2	AL-H48A5/R3VDS1-C2	AL-H60A5/R3VDS1-C2
Power Supply		V~,Hz,Ph	220-240/50/1	380-415/50/3	380-415/50/3
Capacity	Cooling	Btu/h	42000(9800-46000)	48000(16241-56298)	55000(16241-59710)
		KW	12.1(2.9-13.5)	14.0(4.76-16.50)	16.00(4.76-17.5)
	Heating	Btu/h	46000 (8800-51100)	55000(16309-55104)	58000(16308-63122)
		KW	13.5 (2.6-15)	16.00(4.78-16.15)	17.00(4.78-18.50)
Electric Data	Rated Cooling Power Input	W	4.43 (0.71-5.1)	5.0 (1.71-6.6)	5.88 (1.71-6.7)
	Rated Heating Power Input	W	4.6 (0.47-4.53)	5.0 (1.71-6.7)	5.6 (1.71-6.8)
	Rated Cooling Current	A	19 (3.2-22.3)	7.93(2.47~9.53)	9.0(2.47~9.70)
	Rated Heating Current	A	20 (2.43-19.7)	8.23((2.47~9.70)	8.53(2.47~9.83)
Performace	EER/COP	W/W	2.73 /2.93	2.8/3.2	2.72 /3.04
	SEER/SCOP	W/W	6.1 / 4.1	6.1/4.0	6.1/4.0
Indoor Fan Fotor	Model		FP300B-ZL	FP300B-ZL	FP300B-ZL
	Brand		weiling	weiling	weiling
	Output Power x Fan quantity	W	300×1	300×1	300×1
	Capacitor	uF	/	/	/
	Speed (Hi/Mi/Lo)	r/min	1185/1095/1020	1425/1305/1200	1425/1305/1200
Indoor Coil	a.Number Of Row		3	3	3
	b.Tube Pitch(a)x Row Pitch(b)	mm	20.5×12.7	20.5×12.7	20.5×12.7
	c.Fin Spacing	mm	1.5	1.5	1.5
	d.Fin Material		Hydrophilic aluminum fin	Hydrophilic aluminum fin	Hydrophilic aluminum fin
	e.Tube Outside Dia.and Material	mm	φ7 , Inner grooved	φ7 , Inner grooved	φ7 , Inner grooved
	f.Coil Length x	mm	1211*328*38.1	1211*328*38.1	1211*328*38.1

R32 High Efficiency DC Inverter LCAC

	Height x Width				
	g.Heat Exchanging Area	m ²	18.03	18.03	18.03
Indoor Unit	Indoor Air Flow (Hi/Mi/Lo)	m ³ /h	1900/1600/1400	2300/2000/1700	2300/2000/1700
	Sound Pressure Noise Level (Hi/Mi/Lo)	dB(A)	44/41/39	52/49/47	52/49/47
	Sound Power Noise Level	dB(A)	55	64	64
	Net Dimension (W*H*D)	mm	1400×700×245	1400×700×245	1400×700×245
	Packing Dimension (W*H*D)	mm	1630×830×300	1630×830×300	1630×830×300
	Net Weight	Kg	42	42	42
	Gross Weight	Kg	48	48	48
	ESP	Pa	37(0~160)	50(0~160)	50(0~160)
Refrigerant Pipe	Liquid Side	mm	9.52(3/8)	9.52(3/8)	9.52(3/8)
	Gas Side	mm	15.88(5/8)	19.05 (3/4)	19.05 (3/4)
	Drainage	mm	R3/4in(DN20)	R3/4in(DN20)	R3/4in(DN20)
	Max. Refrigerant Pipe Length	m	65	65	65
	Max. Difference In Level	m	30	30	30
Operation Temperature Range		°C	16~32	16~32	16~32
Ambient Temperature Range(Cooling/Heating)		°C	-15~52/-15~24	-15~52/-15~24	-15~52/-15~24
Connection Wiring	Power Wiring(Indoor)	mm ²	3*1.5	3*1.5	3*1.5
	Power Wiring(Outdoor)	mm ²	5*2.5	5*2.5	5*2.5
	Signal Wiring	mm ²	2*0.2	2*0.2	2*0.2
Wireless Remote Controller			/	/	/
Qty'per 20'& 40'&40HQ(Only For Reference)		Set	27/56/69	22/49/52	22/49/52

4. Outdoor Unit

4.1 12K, 18K, 24K, 30K

Model			AL- H12/NDR3A(U)	AL- H18/NDR3A(U)	AL- H24/NDR3A(U)	AL- H30/NDR3A(U)
Factory Model			AL- H12A4/R3VDS 1-C2	AL- H18A4/R3VDS1 -C2	AL- H24A4/R3VDS 1-C2	AL- H30A4/R3VDS1 -C2
Power Supply		V~,Hz,Ph	220-240/50/1	220-240/50/1	220-240/50/1	220-240/50/1
Max. Input Consumption		W	2100	2400	3650	5370
Max. Current		A	11	12	16	23.5
Capacity	Cooling	Btu/h	12000(4600-15000)	18000(5200-19100)	24000(7400-28000)	28660 (8490-31390)
		KW	3.60(1.35-4.40)	5.00(1.53-5.60)	7.00(2.16-8.20)	8.40 (2.49-9.20)
	Heating	Btu/h	14300(4200-18100)	19100(4800-21200)	27300(6800-31700)	30700 (9760-32760)
		KW	4.20(1.24-5.30)	5.60(1.40-6.20)	8.00(1.98-9.30)	9.00 (2.86-9.60)
DC Inverter Compressor	Model		KSN108D22UF Z	KSM135D23UF Z	KTM240D57UK P	KTM240D57UK P
	Type		ROTARY	ROTARY	ROTARY	ROTARY
	Brand		GMCC	GMCC	GMCC	GMCC
	Capacity	W	3470	4245	7715	7715
	Input	W	890	1075	2085	2085
	Frequency range	Hz	10-120	10-120	12-120	12-120
	Rated Current (RLA)	A	6.05	7.1	9.5	9.5
	Refrigerant Oil	ml	310 (VG74)	440 (VG74)	670 (VG74)	670 (VG74)
Outdoor Fan Motor	Model		D-40-8	D-40-8	D-69-8	D-310-120-8A
	Brand		WELLING	WELLING	WELLING	WOLONG
	Output Power x Fan quantity	W	40×1	40×1	69×1	120×1
	Capacitor	uF	/	/	/	/
	Speed	r/min	850	850	870	940
Coil	a.Number Of Row		2	2	2	2
	b.Tube Pitch(a) x Row Pitch(b)	mm	22×19.05	22×19.05	22×19.05	22×19.05
	c.Fin Pitch	mm	1.4	1.4	1.5	1.5
	d.Fin		Hydrophilic	Hydrophilic	Hydrophilic	Hydrophilic

R32 High Efficiency DC Inverter LCAC

	Material		aluminum fin	aluminum fin	aluminum fin	aluminum fin
	e.Tube Outside Dia.And Material	mm	φ7.94 , Inner grooved	φ7.94 , Inner grooved	φ7.94 , Inner grooved	φ7 , Inner grooved
	f.Coil Length x Height x Width	mm	835×506×38.1	835×506×38.1	857×660×38.1	1017×759×38.1
	g.Heat Exchanging Area	m ²	18.4	18.4	24.4	34.33
Air Flow Volume		CFM	1529	1529	2206	2235
		m ³ /h	2600	2600	3750	3800
Sound Pressure Noise Level		dB(A)	54	55	58	57
Sound Power Noise Level		dB(A)	64	64	67	68
Dimension(W×D×H)	Net	mm	800×315×545	800×315×545	900×350×700	970×395×805
	Packing	mm	920x400x620	920x400x620	1020×430×770	1105×495×895
Weight	Net	kg	35	37	51	65
	Gross	kg	38	40	55	69
Refrigerant Type/Quantity	Type		R32	R32	R32	R32
	Charge d Volume	kg	0.9	1.16	1.4	1.60
Design Pressure		MPa	4.2	4.2	4.2	4.2
Refrigerant Piping	Liquid Side	mm	6.35(1/4)	6.35(1/4)	9.52(3/8)	9.52
	Gas Side	mm	12.7(1/2)	12.7(1/2)	15.88(5/8)	15.88
	Drainage	mm	R3/4in(DN20)	R3/4in(DN20)	R3/4in(DN20)	R3/4in (DN20)
	Max. Length	m	25	30	50	50
	Max. Height	m	10	20	25	25
Operation Temperature Range		°C	16~32	16~32	16~32	16~32
Ambient Temperature Range(Cooling/Heating)		°C	-15~52/-15~24	-15~52/-15~24	-15~52/-15~24	-15~52/-15~24
Connection Wiring	Power Wiring (Indoor)	mm ²	3*1.5	3*1.5	3*1.5	3*1.5
	Power Wiring (Outdoor)	mm ²	5*2.5	5*2.5	5*2.5	5*2.5
	Signal Wiring	mm ²	2*0.2	2*0.2	2*0.2	2*0.2
Stuffing Quantity	20/40/40H	Unit	102/219/292	102/219/292	87/183/183	44/96/144

R32 High Efficiency DC Inverter LCAC

4.2 36K, 42K,48K, 60K

Model			AL- H36/NDR3A(U)	AL- H42/NDR3A(U)	AL- H48/SDR3A(U)	AL- H60/SDR3A(U)
Factory Model			AL- H36A4/R3VDS 1-C2	AL- H42A4/R3VDS1 -C2	AL- H48A5/R3VDS 1-C2	AL- H60A5/R3VDS1 -C2
Power Supply		V~,Hz,Ph	220-240/50/1	220-240/50/1	380-415/50/3	380-415/50/3
Max. Input Consumption		W	5370	5730	6800	6900
Max. Current		A	23.5	24.9	27	27
Capacity	Cooling	Btu/h	36000 (9800-44300)	42000 (9800-46000)	48000(16241-56298)	55000(16241-59710)
		KW	10.55 (2.9-13)	12.1 (2.9-13.5)	14.00(4.76-16.50)	16.00(4.76-17.5)
	Heating	Btu/h	38000 (8800-46000)	46000 (8800-51100)	55000(16309-55104)	58000(16308-63122)
		KW	11.15 (2.6-13.5)	13.5 (2.6-15)	16.00(4.78-16.15)	17.00(4.78-18.50)
DC Inverter Compressor	Model		KTF310D43UM T	KTF310D43UM T	KTF400D66UM VA	KTF400D66UM VA
	Type		ROTOR	ROTOR	ROTOR	ROTOR
	Brand		GMCC	GMCC	GMCC	GMCC
	Capacity	W	10010	10010	13100	13100
	Input	W	2765	2765	3465	3465
	Frequency range	Hz	12-120	12-120	12-120	12-120
	Rated Current (RLA)	A	5.38	5.38	6.65	6.65
	Refrigerant Oil	ml	1000 (VG74)	1000 (VG74)	1400 (VG74)	1400 (VG74)

R32 High Efficiency DC Inverter LCAC

Outdoor Fan Motor	Model		D-310-120-8A	D-310-120-8A	CW100A-ZL	CW100A-ZL
	Brand		WOLONG	WOLONG	Panasonic	Panasonic
	Output Power x Fan quantity	W	120×1	120×1	100×2	100×2
	Capacitor	uF	/	/	/	/
	Speed	r/min	940	940	780	780
Coil	a.Number Of Row		3	3	2.5	2.5
	b.Tube Pitch(a) x Row Pitch(b)	mm	20.5×19.05	20.5×19.05	22×19.05	22×19.05
	c.Fin Pitch	mm	1.4	1.4	1.6	1.6
	d.Fin Material		Hydrophilic aluminum fin	Hydrophilic aluminum fin	Hydrophilic aluminum fin	Hydrophilic aluminum fin
	e.Tube Outside Dia.And Material	mm	φ7 , Inner grooved	φ7 , Inner grooved	φ7 , Inner grooved	φ7 , Inner grooved
	f.Coil Length x Height x Width	mm	1017×759×38.1	1017×759×38.1	1276×891×57.1	1276×891×57.1
	g.Heat Exchanging Area	m ²	58.33	58.33	78.67	78.67
Air Flow Volume	CFM		2353	2471	4235	4235
	m ³ /h		4000	4200	7200	7200
Sound Pressure Noise Level	dB(A)		57	57	60	60
Sound Power Noise Level	dB(A)		66	66	70	70
Dimension(W×D×H)	Net	mm	970×395×805	970×395×805	940×370×1325	940×370×1325
	Packing	mm	1105×495×895	1105×495×895	1080×430×1440	1080×430×1440
Weight	Net	kg	72	72	92	92
	Gross	kg	76	76	102	102
Refrigerant Type/Quantity	Type		R32	R32	R32	R32
	Charge d Volume	kg	2.54	2.54	3.6	3.6
Design Pressure	MPa		4.2	4.2	4.2	4.2
Refrigerant Piping	Liquid Side	mm	9.52	9.52	9.52	9.52
	Gas Side	mm	15.88	15.88	19.05	19.05
	Drainage	mm	R3/4in (DN20)	R3/4in (DN20)	R3/4in (DN20)	R3/4in (DN20)
	Max.	m	65	65	65	65

R32 High Efficiency DC Inverter LCAC

	Length					
	Max. Height	m	30	30	30	30
Operation Temperature Range		°C	16~32	16~32	16~32	16~32
Ambient Temperature Range(Cooling/Heating)		°C	-15~52/-15~24	-15~52/-15~24	-15~52/-15~24	-15~52/-15~24
Connection Wiring	Power Wiring (Indoor)	mm ²	3*1.5	3*1.5	3*1.5	3*1.5
	Power Wiring (Outdoor)	mm ²	5*2.5	5*2.5	5*2.5	5*2.5
	Signal Wiring	mm ²	2*0.2	2*0.2	2*0.2	2*0.2
Stuffing Quantity	20/40/40H	Unit	44/96/144	44/96/144	27/55/55	27/55/55

Part5 Dimension

1. Cassette

1.1 12K, 18K

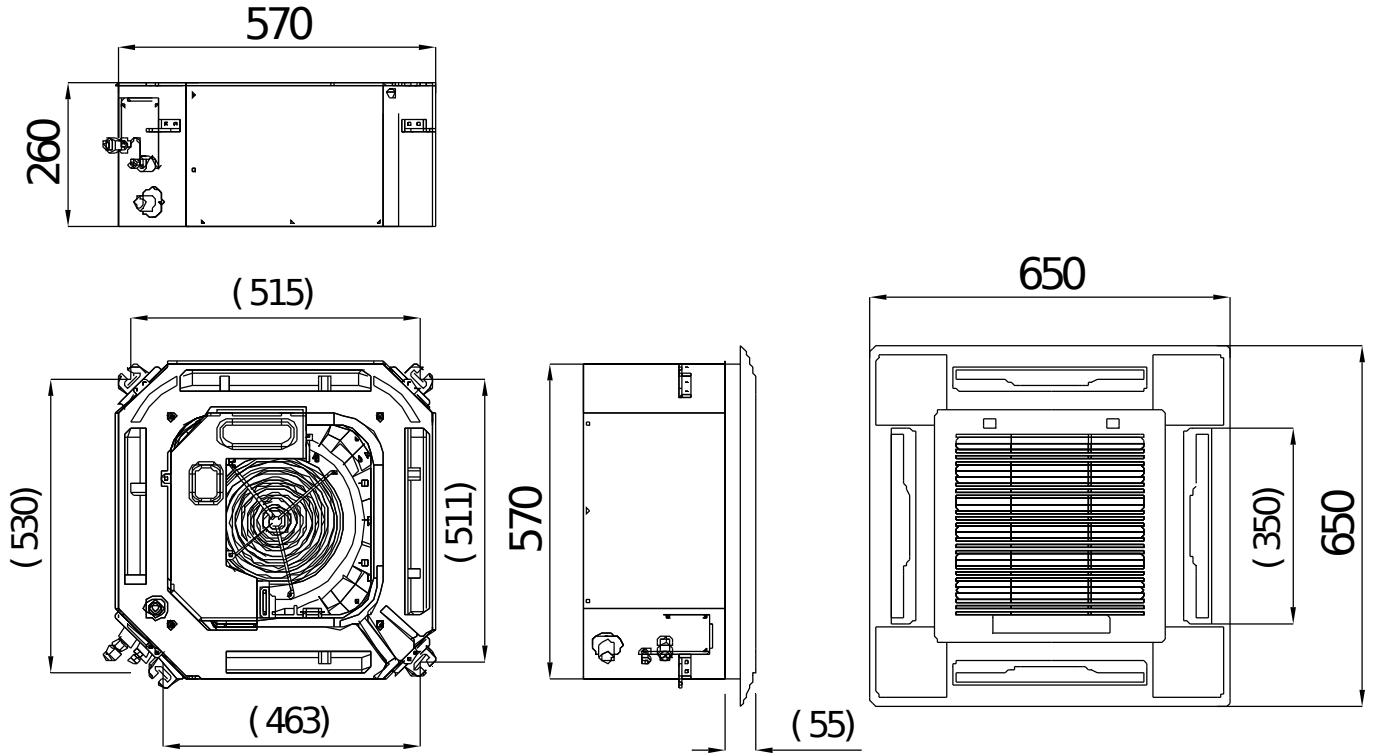

1.2 24K

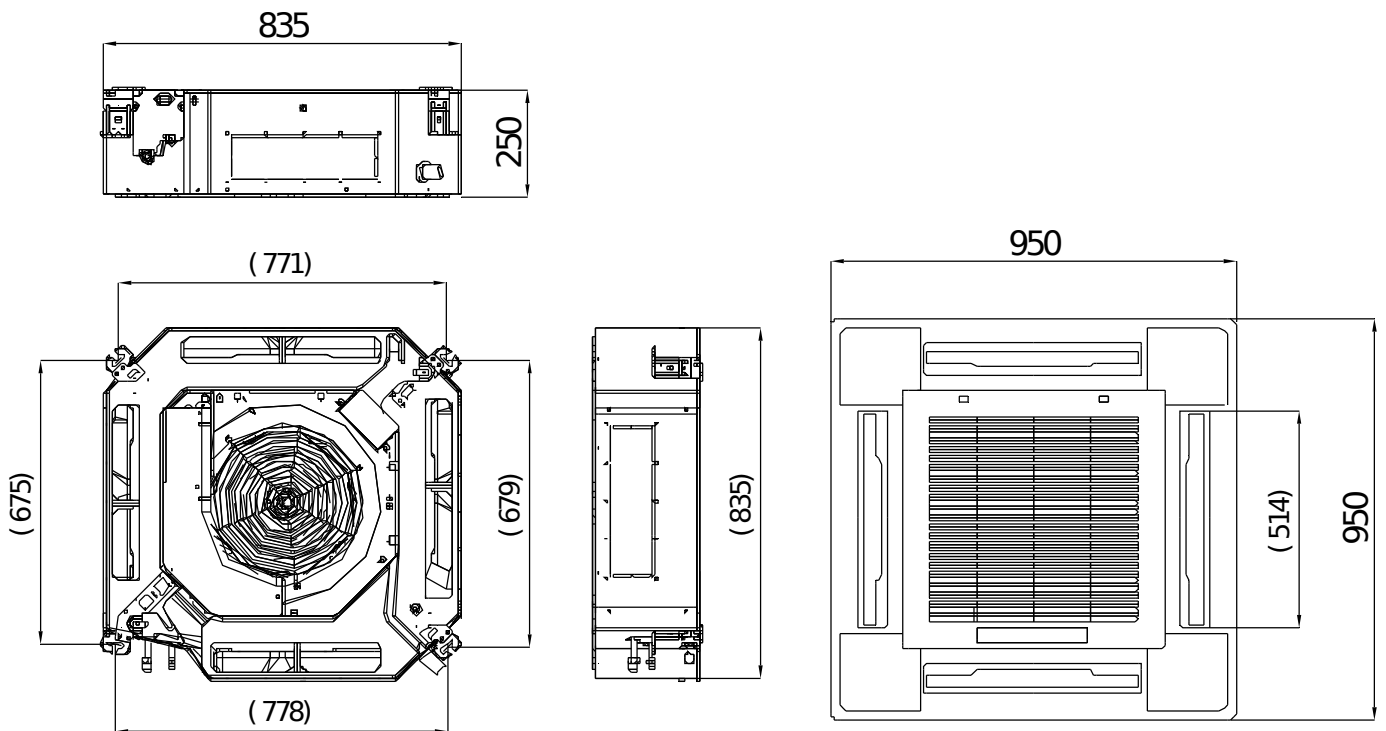

R32 High Efficiency DC Inverter LCAC

1.3 36K, 42K , 48K,60K

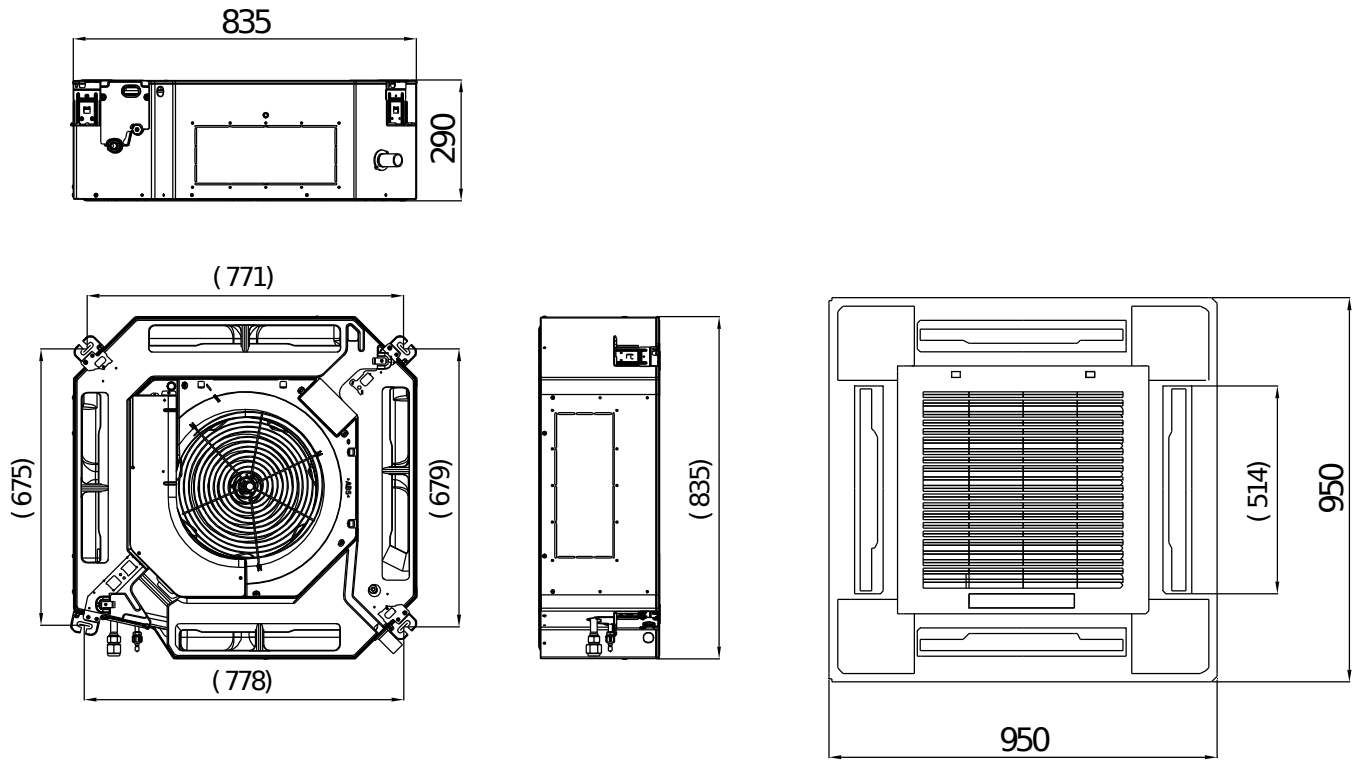

2. Ceiling Floor

2.1 18K

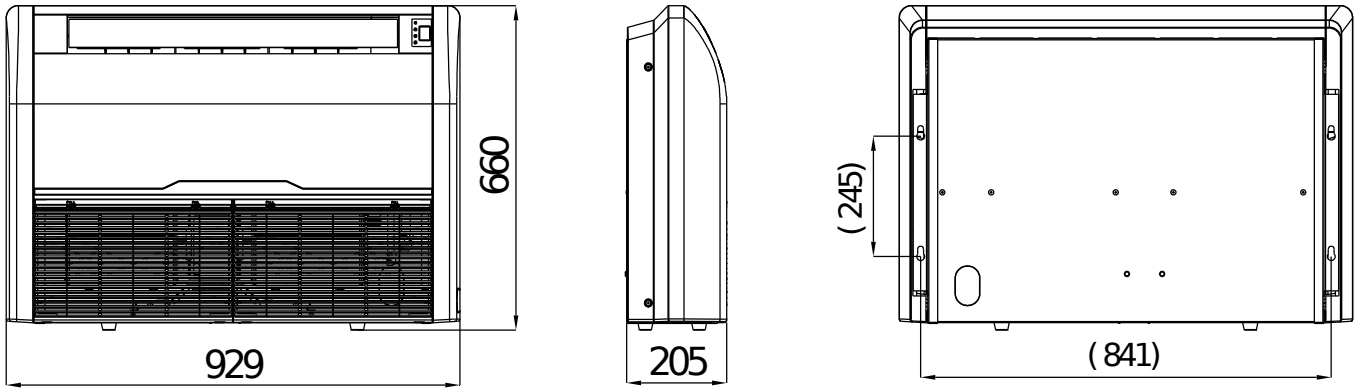

2.2 24K

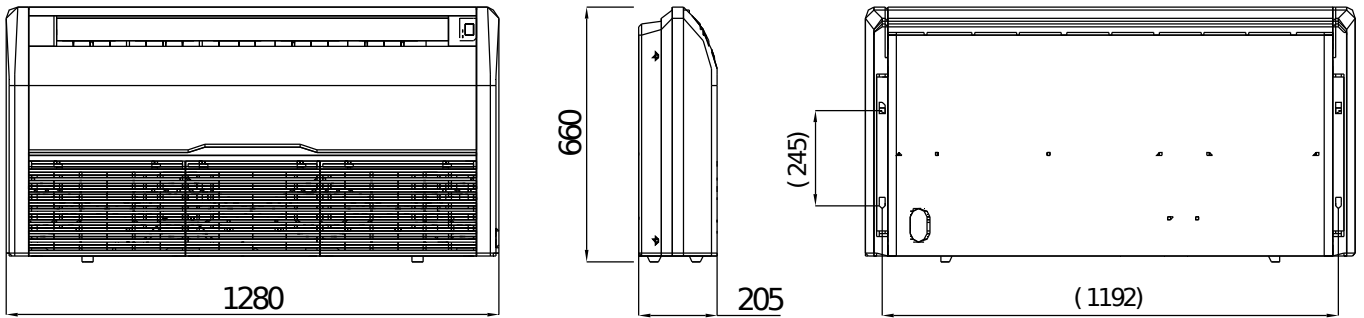

2.3 36K,42K,48K,60K

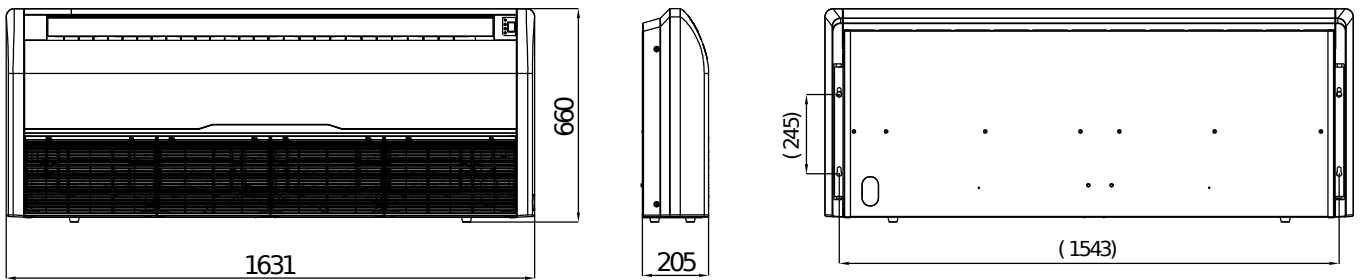

3. Duct

3.1 18K, 24K, 30K

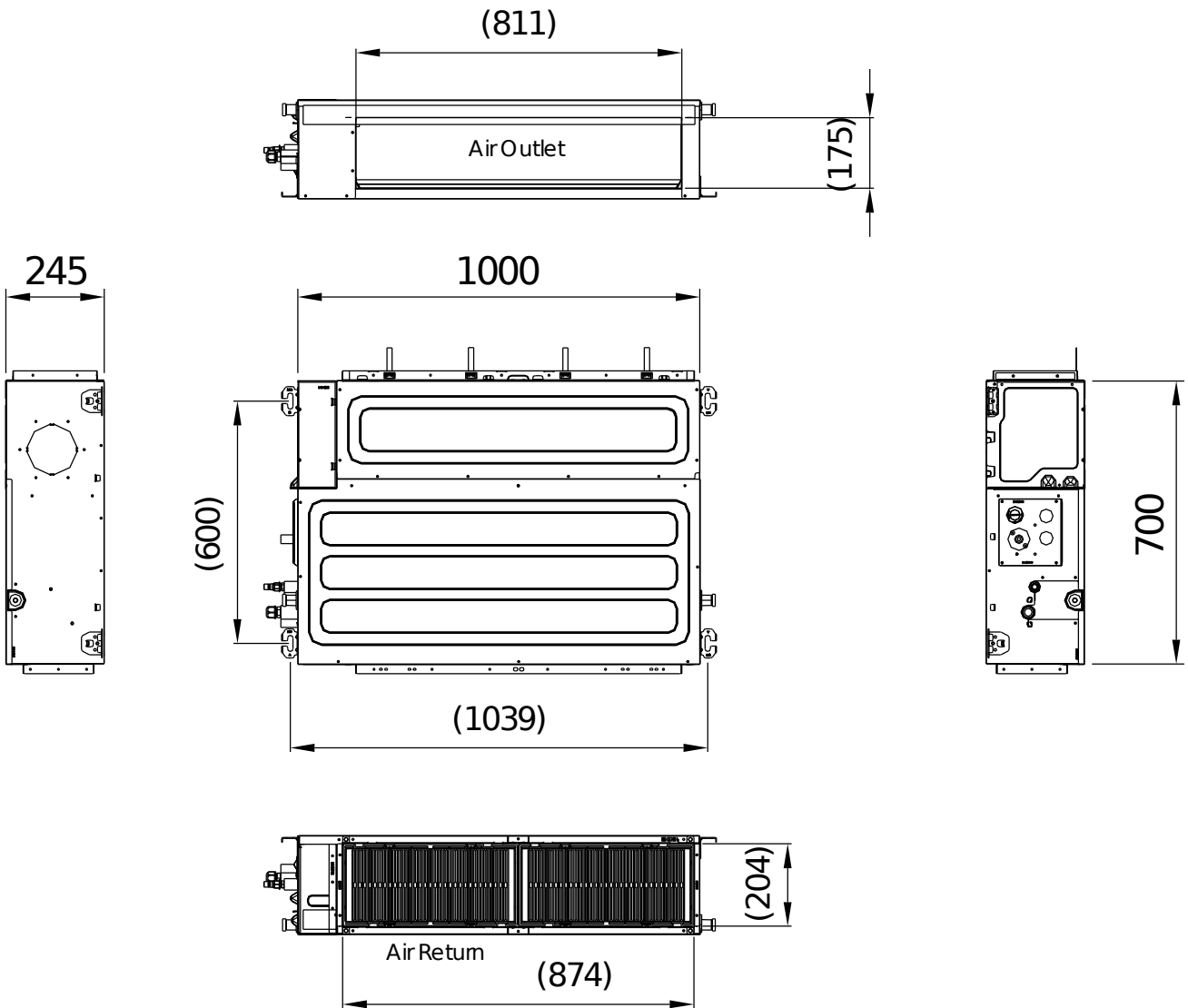

R32 High Efficiency DC Inverter LCAC

3.2 36K, 42K,48K,60K

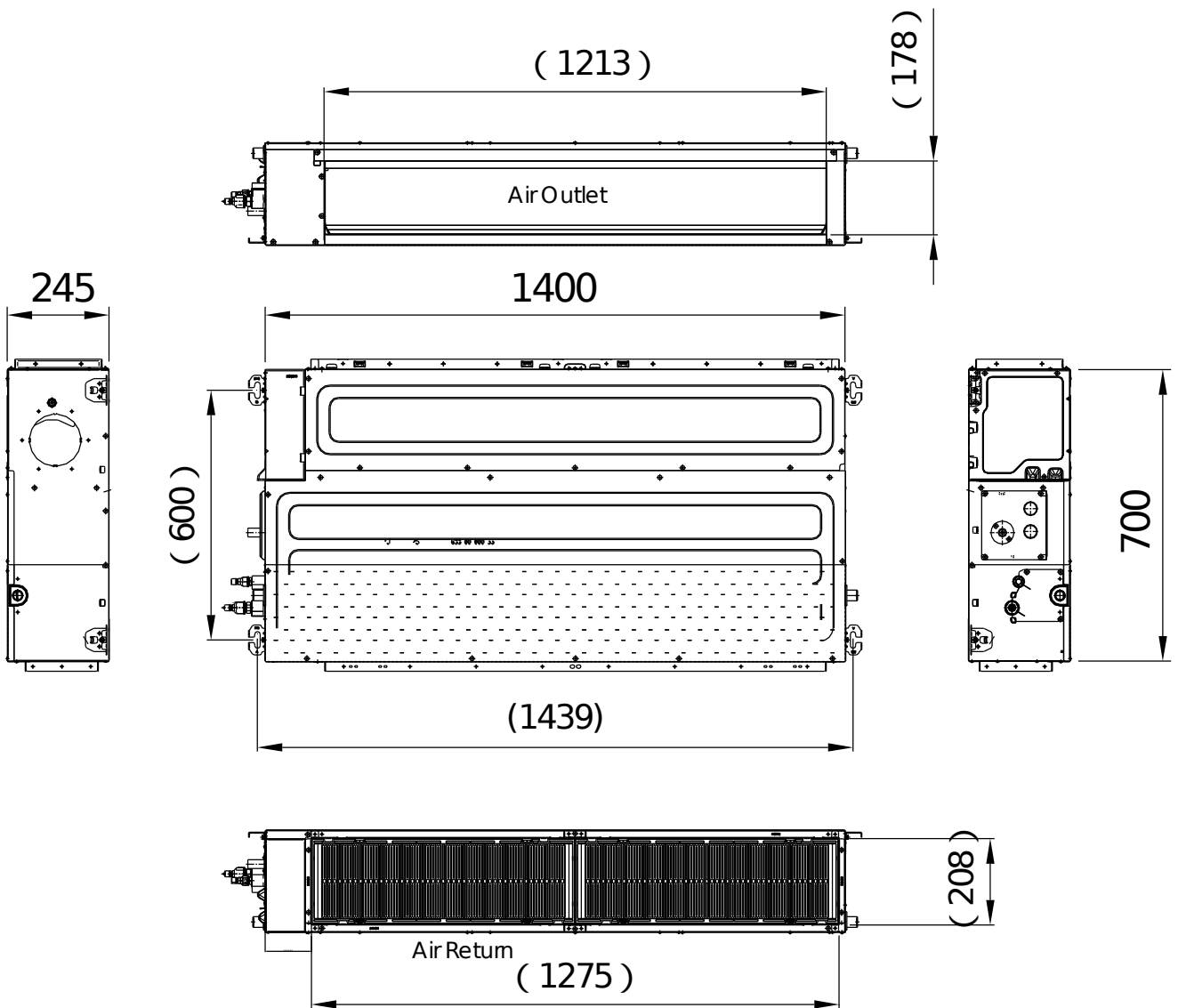

4. Outdoor Unit

4.1 12K, 18K

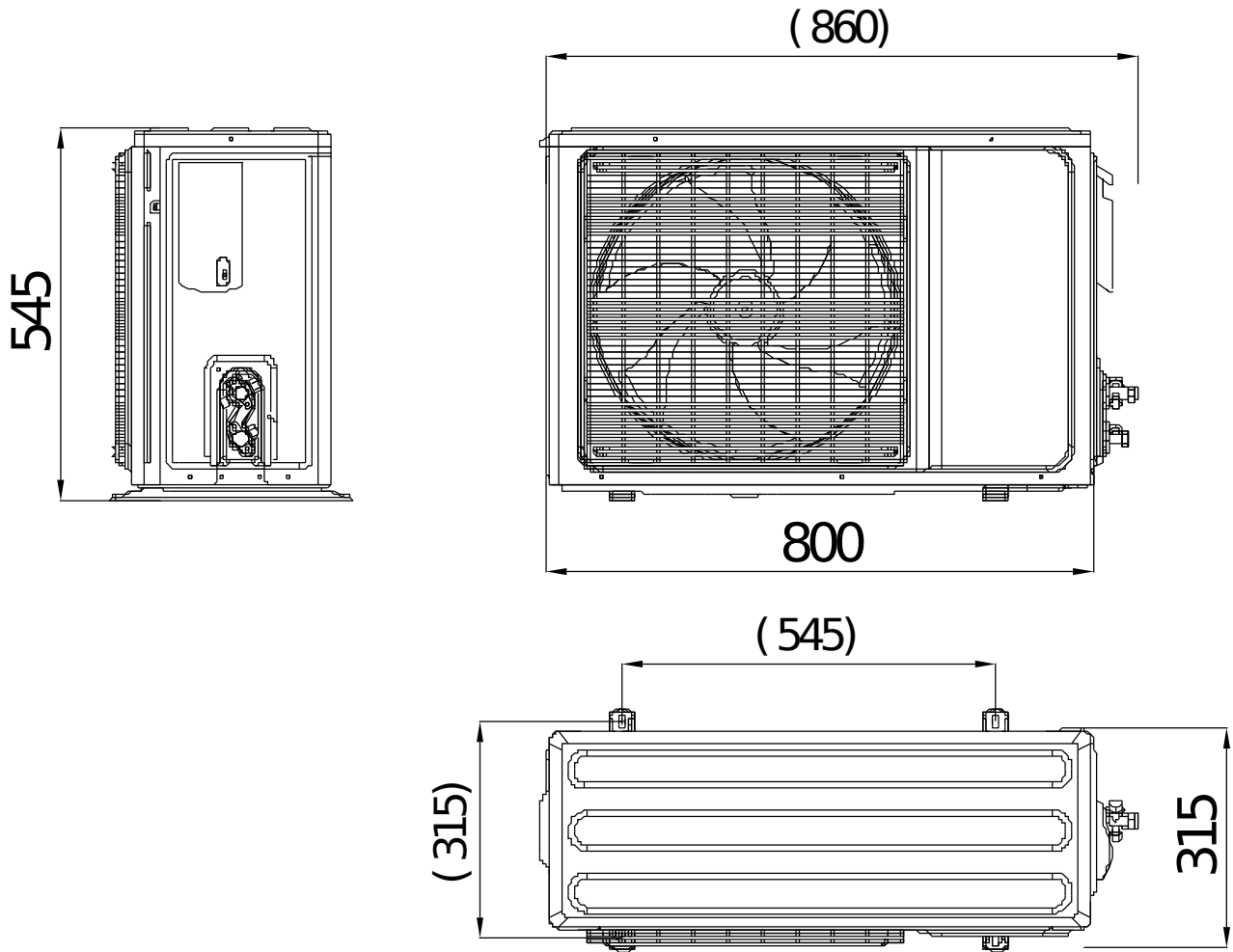

R32 High Efficiency DC Inverter LCAC

4.2 24K

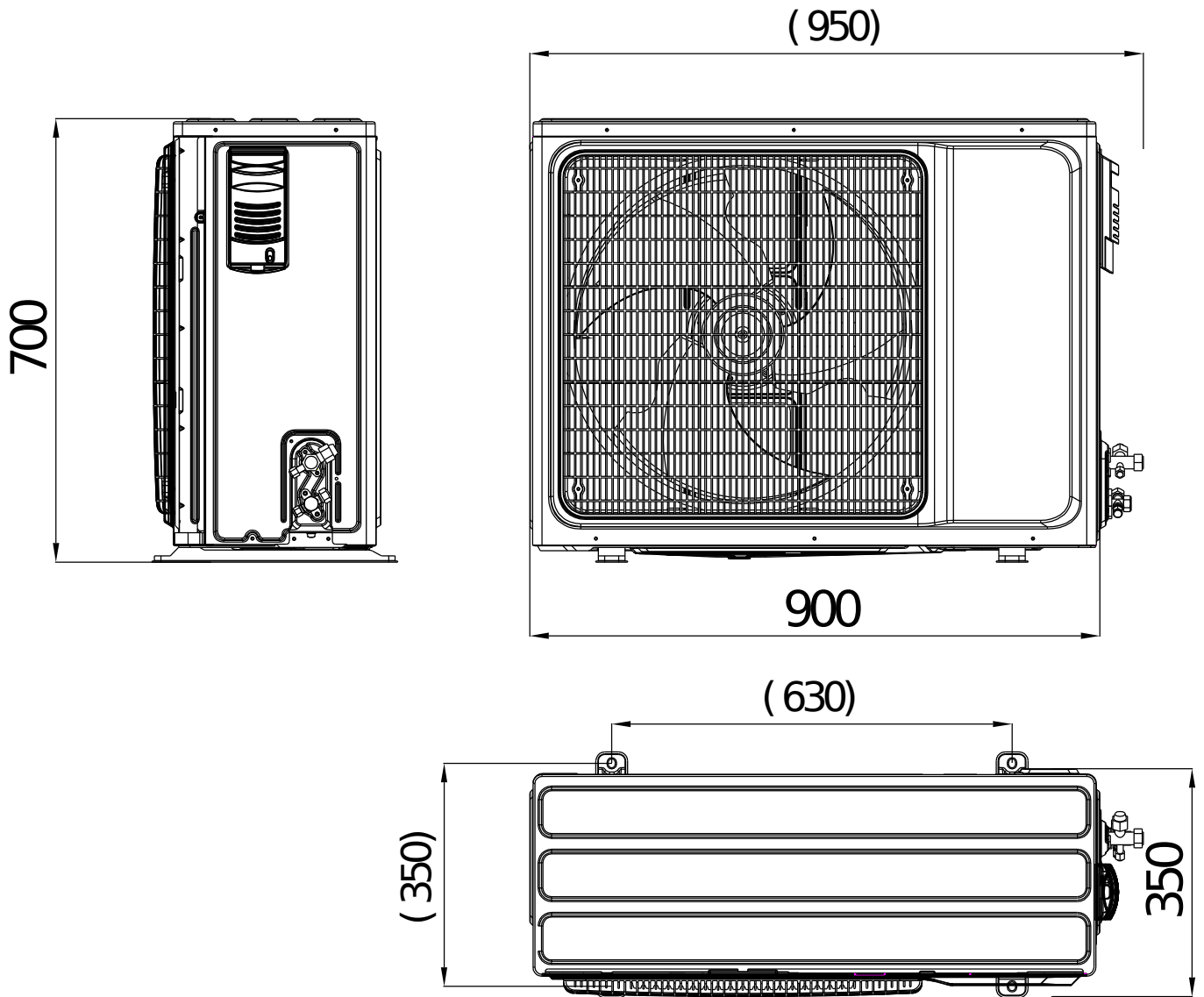

R32 High Efficiency DC Inverter LCAC

4.3 30K, 36K, 42K

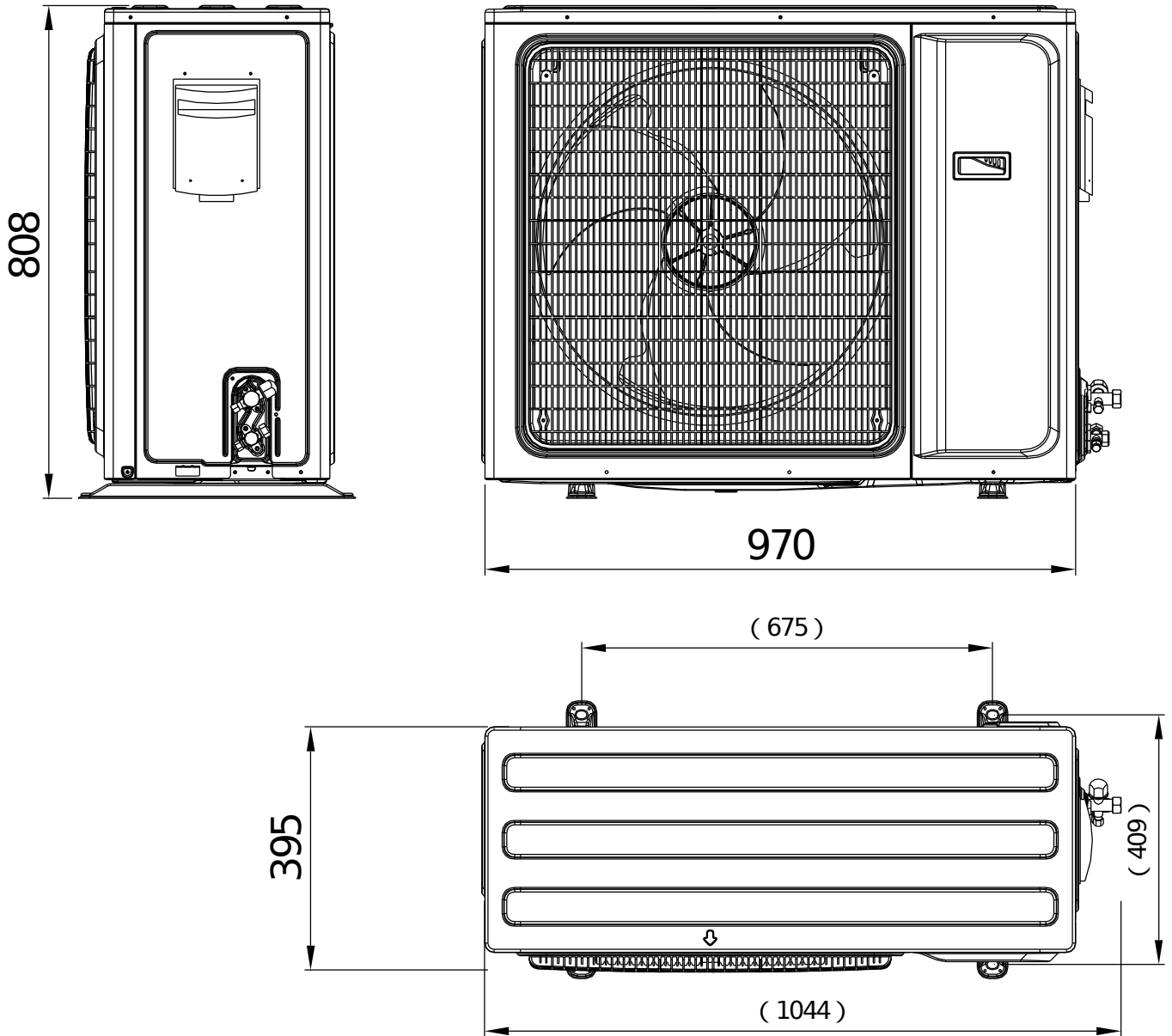

R32 High Efficiency DC Inverter LCAC

4.4 48K, 60K

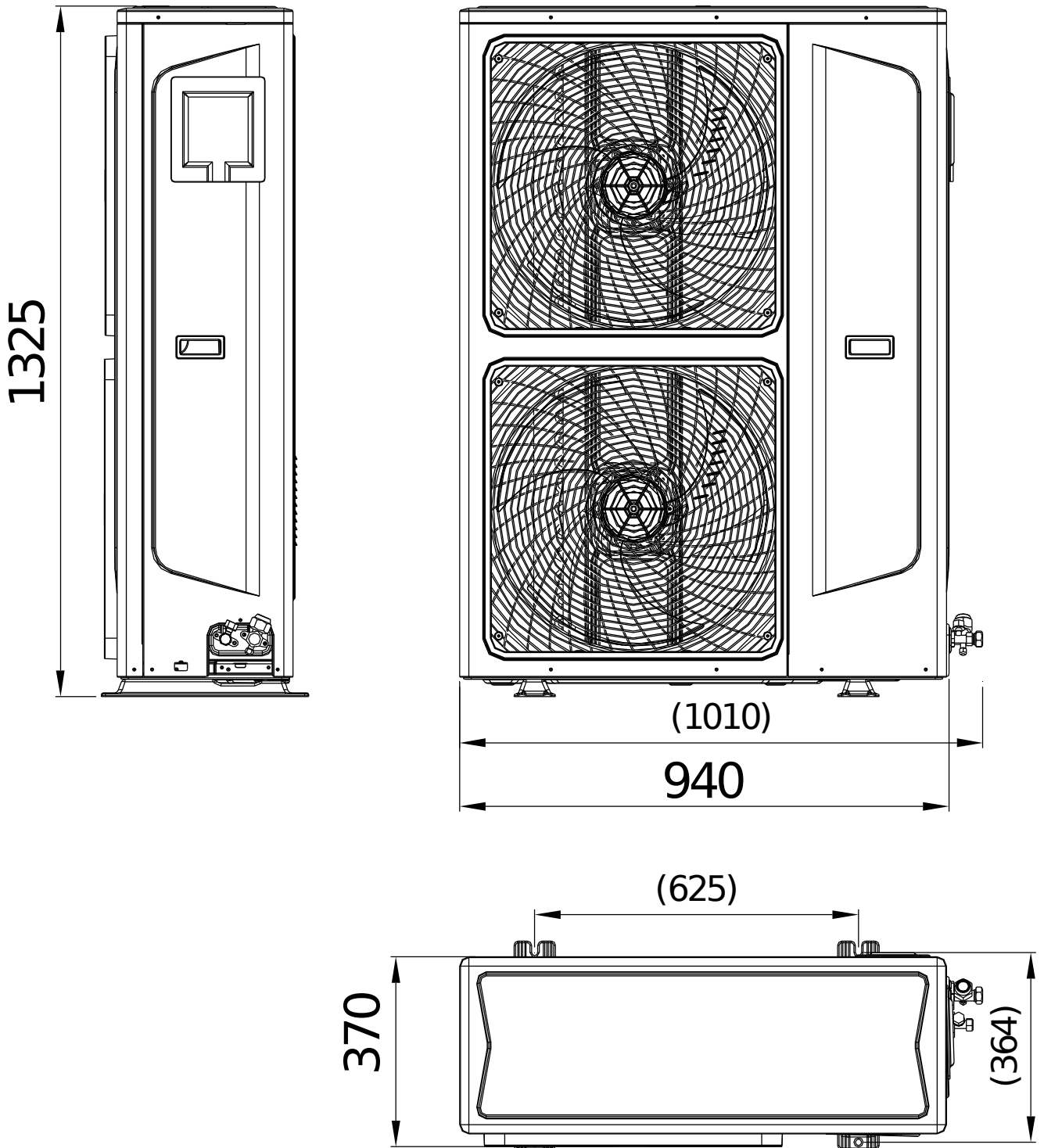

Part6 Electrical Principle Diagram

1. Cassette

1.1 12K, 18K

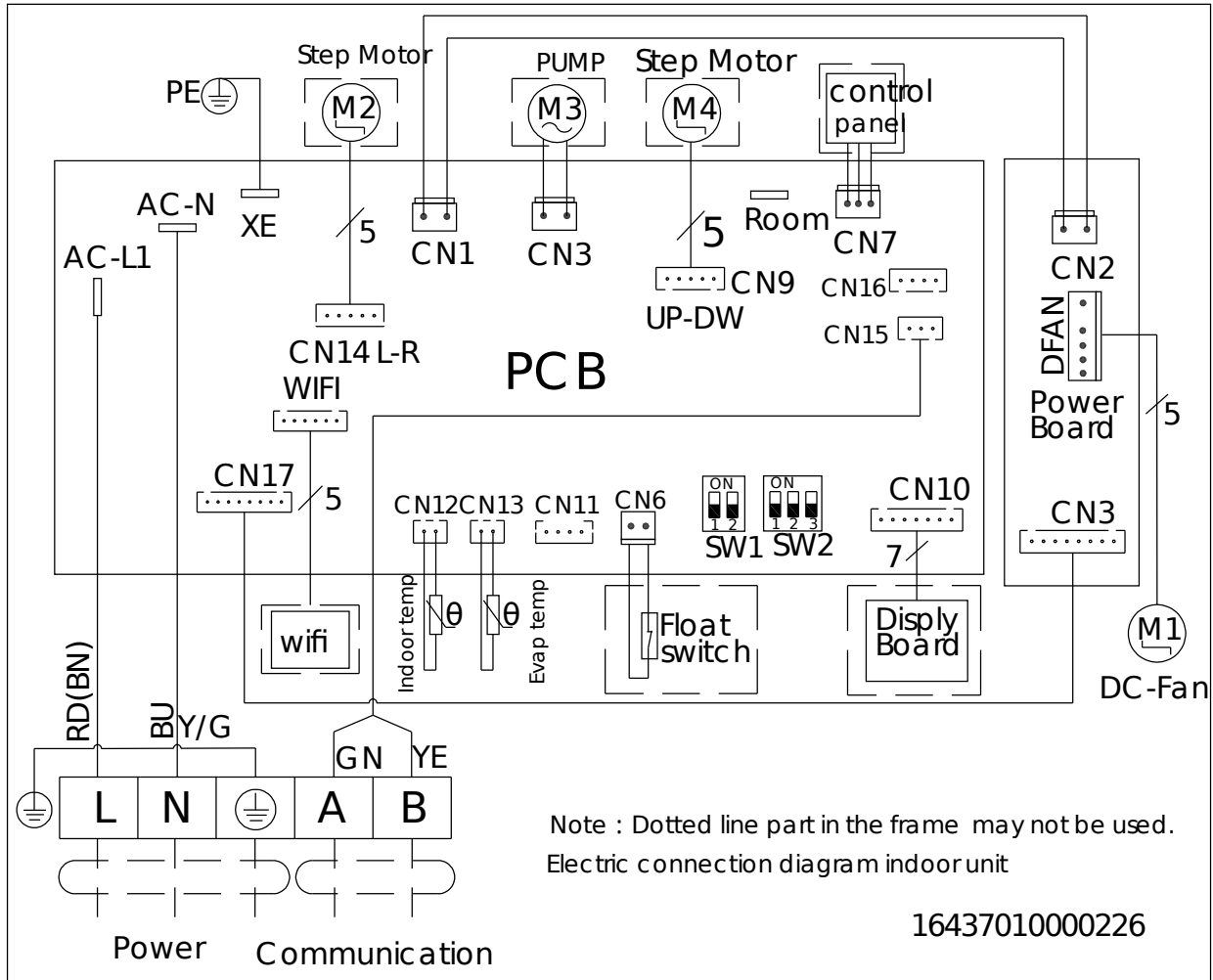

R32 High Efficiency DC Inverter LCAC

1.2 24K, 36K, 42K, 48K, 60K

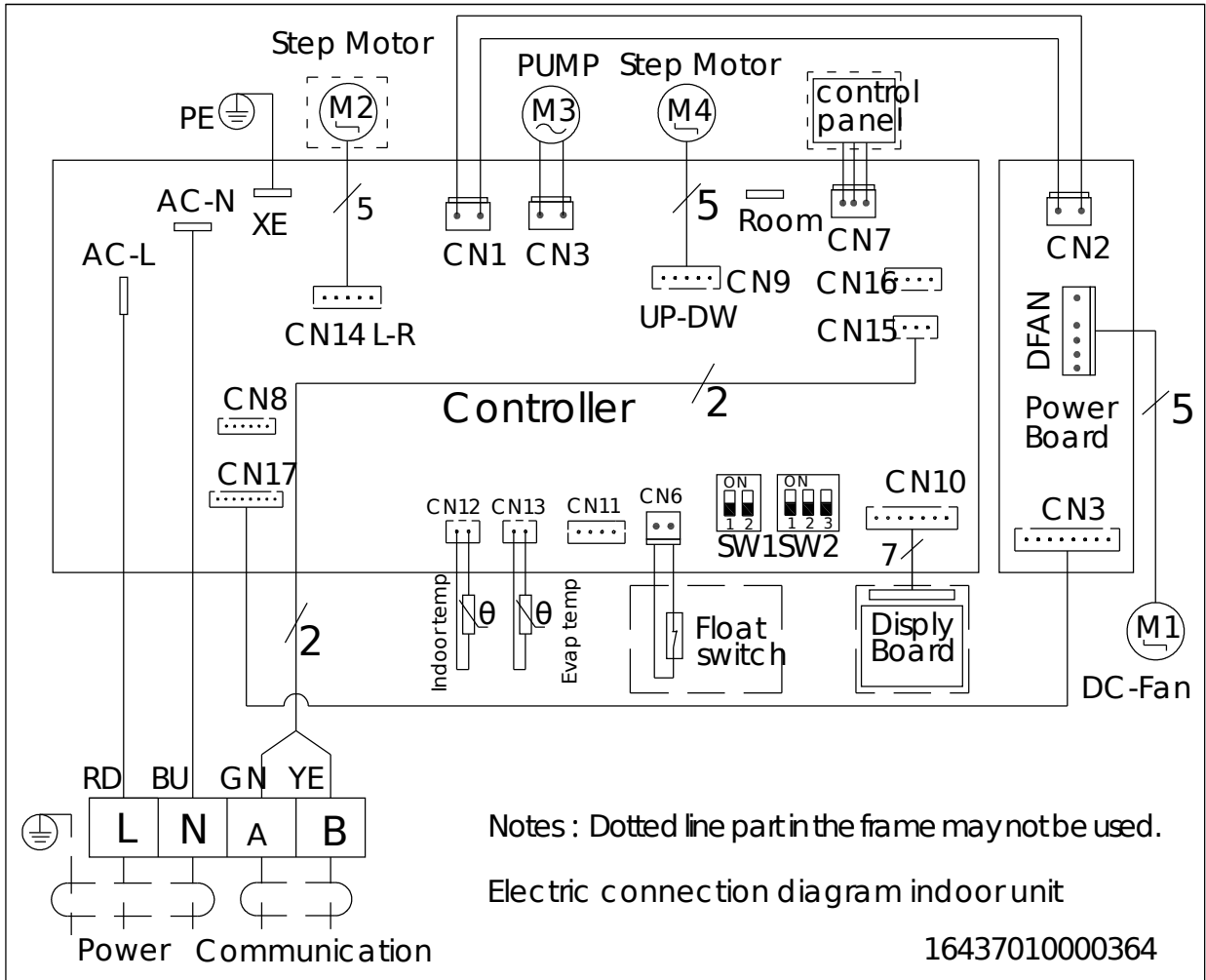

2. Ceiling Floor

2.1 18K, 24K, 36K, 42K, 48K, 60K

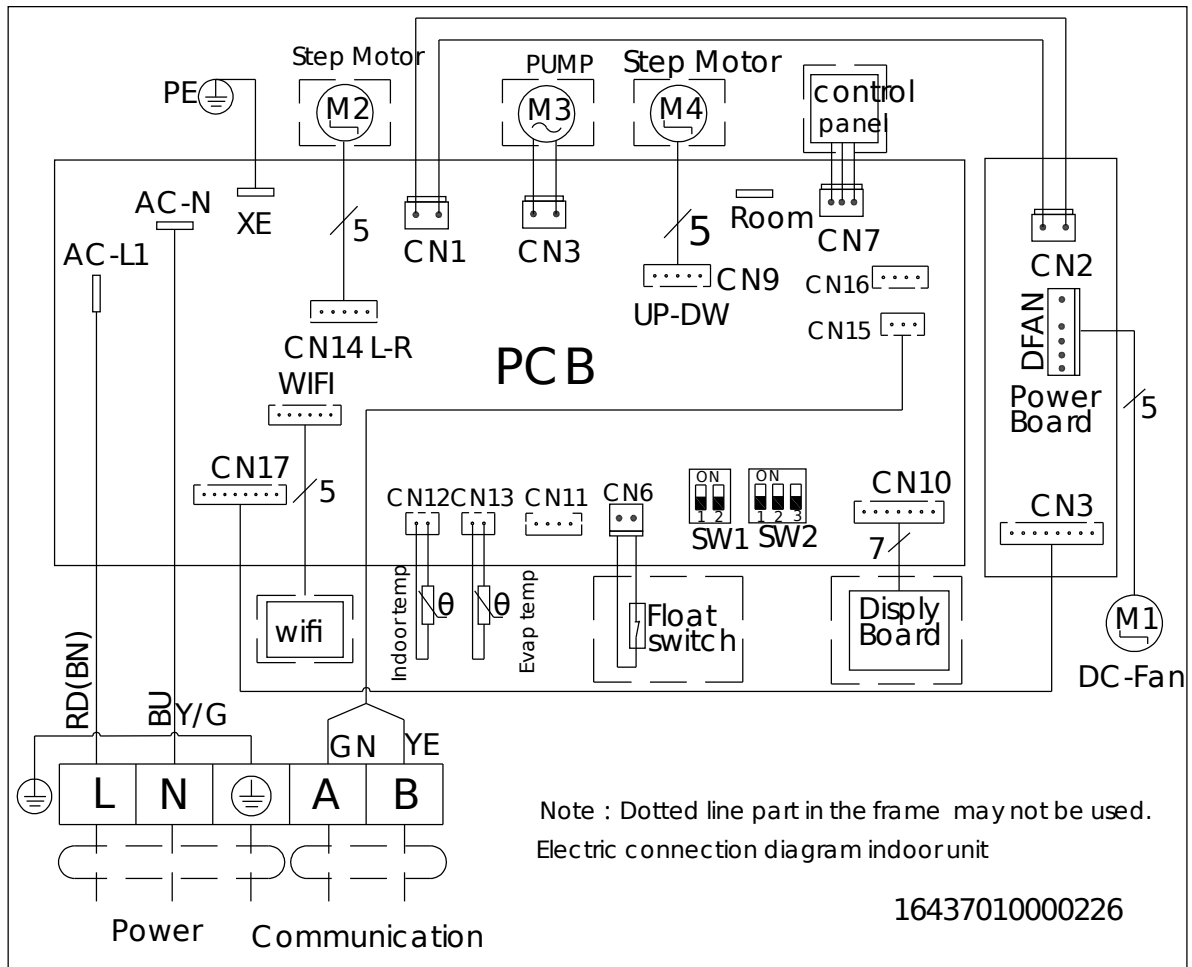

R32 High Efficiency DC Inverter LCAC

3. Duct

3.1 18K, 24K, 30K, 36K, 42K,48K,60K

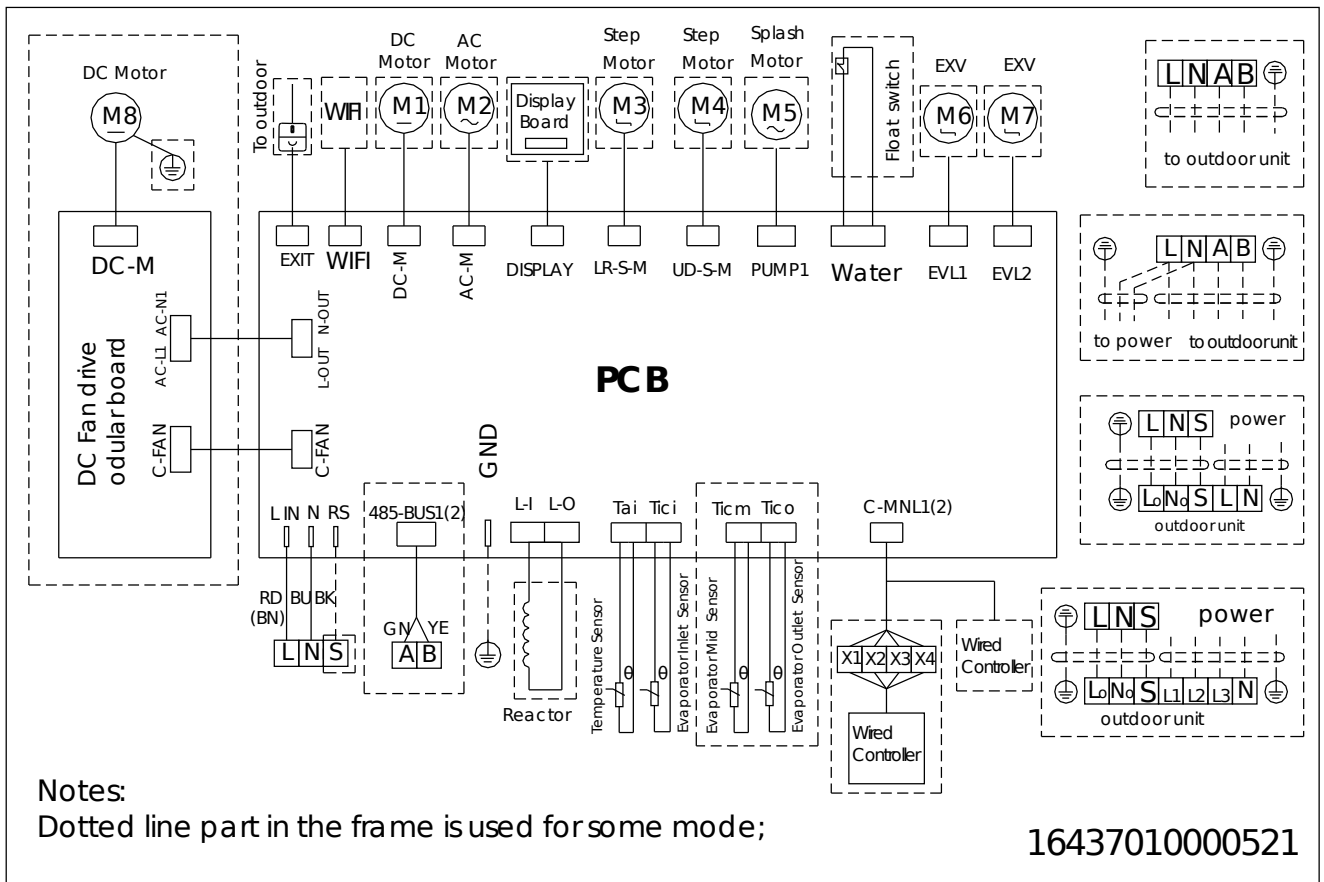

R32 High Efficiency DC Inverter LCAC

4. Outdoor Unit

4.1 12K, 18K, 24K

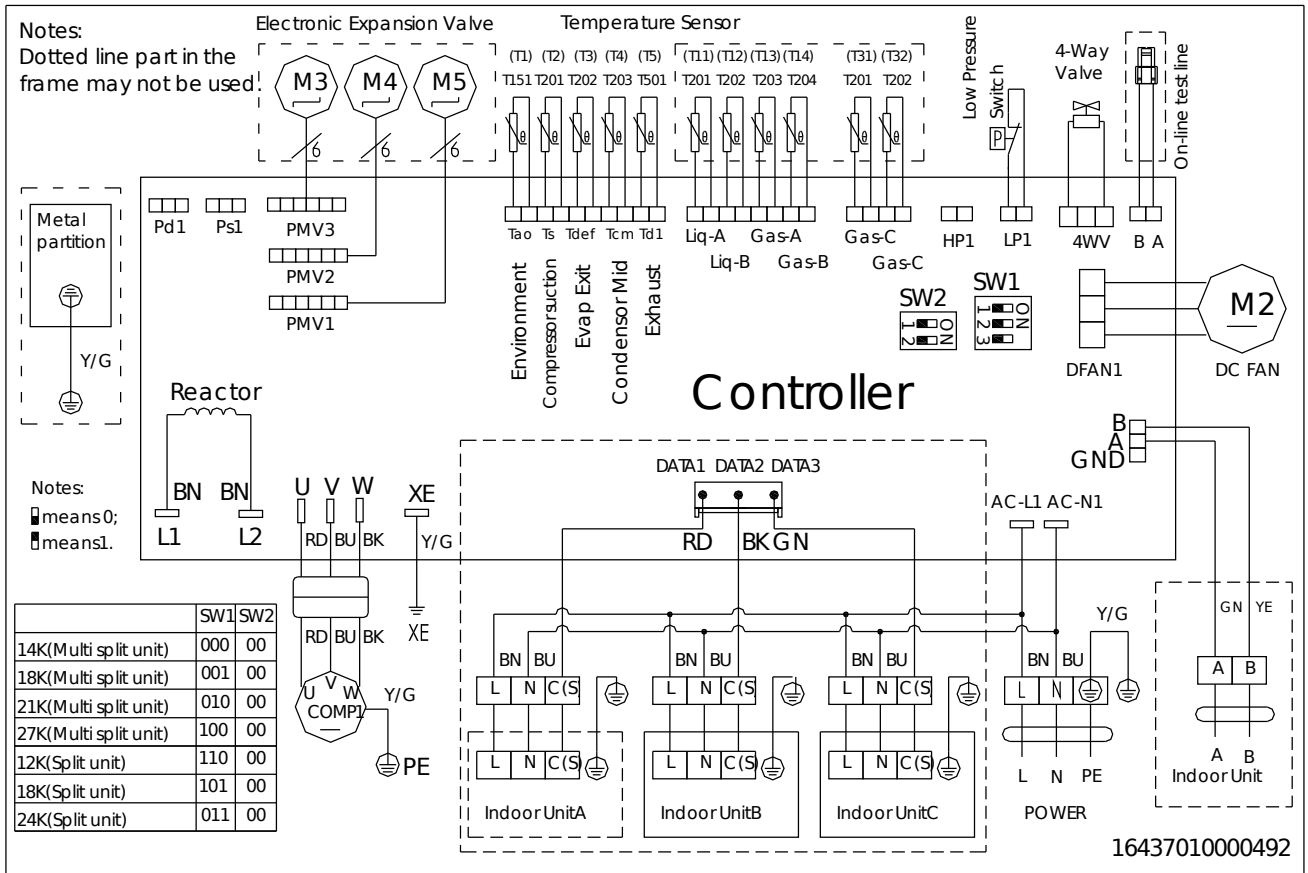

R32 High Efficiency DC Inverter LCAC

4.2 30K, 36K, 42K

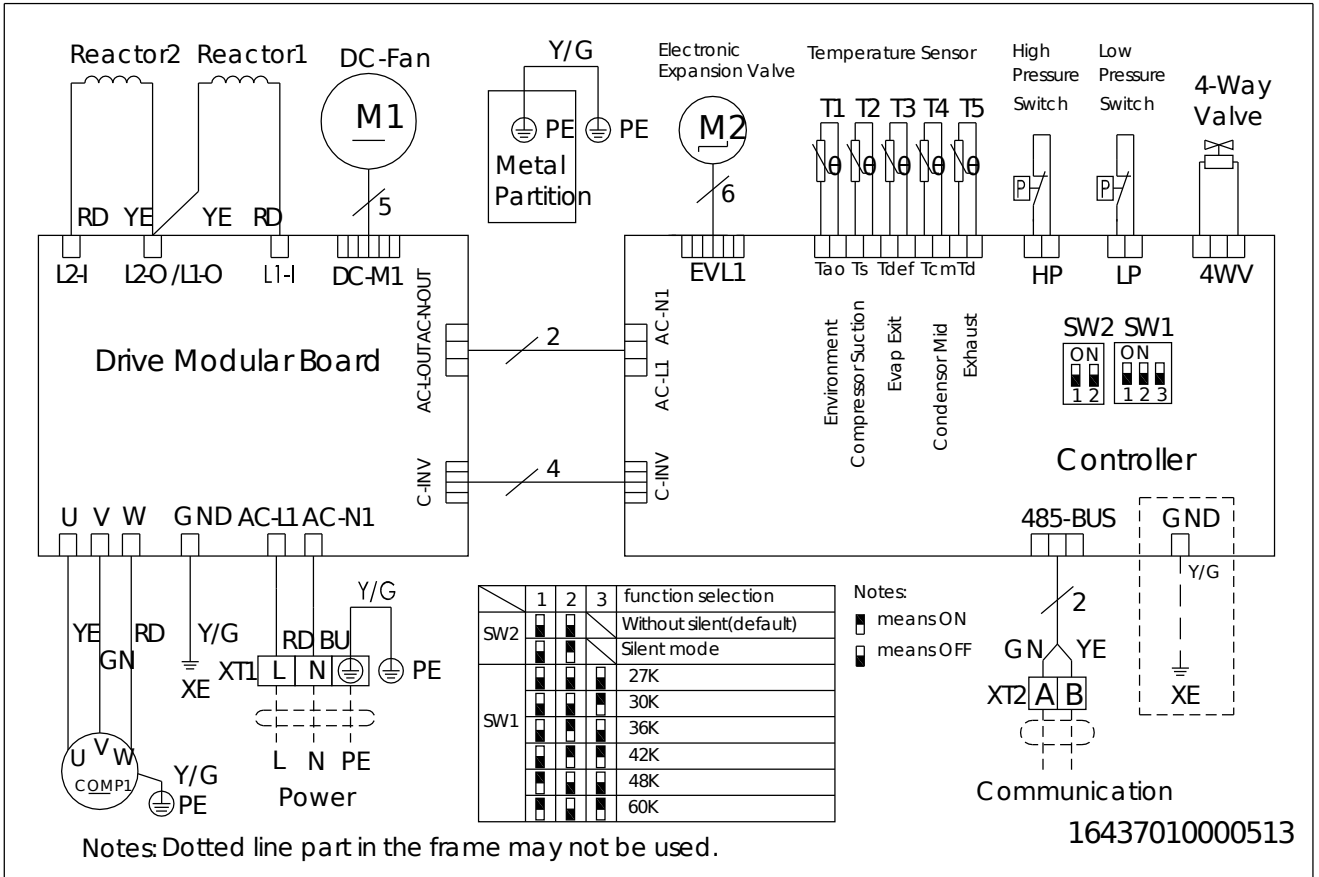

	1	2	3	function selection
SW2	<input type="checkbox"/>	<input type="checkbox"/>	<input type="checkbox"/>	Without silent(default)
	<input type="checkbox"/>	<input type="checkbox"/>	<input type="checkbox"/>	Silent mode
SW1	<input type="checkbox"/>	<input type="checkbox"/>	<input type="checkbox"/>	27K
	<input type="checkbox"/>	<input type="checkbox"/>	<input type="checkbox"/>	30K
	<input type="checkbox"/>	<input type="checkbox"/>	<input type="checkbox"/>	36K
	<input type="checkbox"/>	<input type="checkbox"/>	<input type="checkbox"/>	42K
	<input type="checkbox"/>	<input type="checkbox"/>	<input type="checkbox"/>	48K
	<input type="checkbox"/>	<input type="checkbox"/>	<input type="checkbox"/>	60K

Notes:
 means ON
 means OFF

R32 High Efficiency DC Inverter LCAC

4.2 48K, 60K

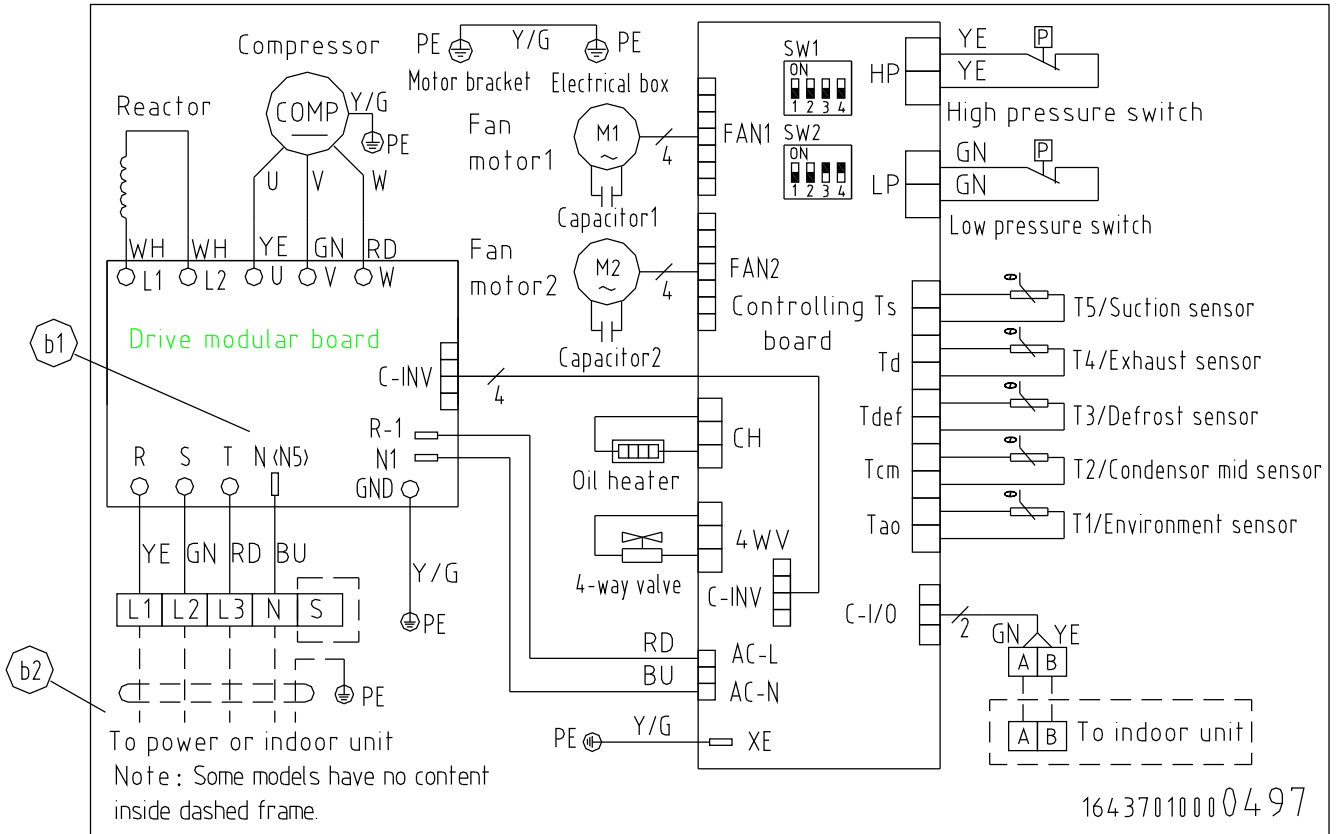

Part7 Capacity Amendment

1. Operation range

Cooling capacity (KBtu/h)		12K	18K	24K	30K	36K	42K	48K	60K	
Power supply		220-240V~/50Hz						380-415V~/50Hz		
Voltage		187~242V						342~456V		
Ambient temperature	Cooling	-10~52°C								
	Heating	15~24°C								

2. Capacity amendment of different ambient temperature

2.1 Amendment coefficient of Cooling capacity under different indoor/outdoor DB/WB temperature K1

IDU temp.°C		Outdoor air inlet DB temperature°C										
DB	WB	-10	0	10	16	25	30	35	40	43	48	52
23	16	1.19	1.12	1.08	1.05	1	0.95	0.90	0.87	0.85	0.82	0.77
25	18	1.26	1.19	1.12	1.08	1.05	1	0.95	0.90	0.87	0.85	0.82
27	19	1.28	1.26	1.19	1.12	1.08	1.05	1	0.95	0.90	0.87	0.85
28	20	1.30	1.28	1.26	1.19	1.12	1.08	1.05	1	0.95	0.90	0.87
30	22	1.33	1.30	1.28	1.26	1.19	1.12	1.08	1.05	1	0.95	0.90
32	24	1.5	1.33	1.30	1.28	1.26	1.19	1.12	1.08	1.05	1	0.95

Actual cooling capacity calculation:

Actual cooling capacity=amendment coefficient of cooling capacity × nominal cooling capacity

——Rated cooling capacity could be found from 【Part 4 Specification】

——Amendment coefficient of cooling capacity could be found from table above.

R32 High Efficiency DC Inverter LCAC

2.2 Amendment coefficient of Heating capacity under different indoor/outdoor DB/WB temperature K2

IDU temp. °C	Outdoor air inlet DB temperature°C									
	DB	-15	-10	-5	0	7	10	15	20	24
16		0.93	0.97	1	1.06	1.08	1.1	1.14	1.2	1.25
18		0.87	0.93	0.97	1	1.06	1.08	1.1	1.14	1.2
20		0.8	0.87	0.93	0.97	1	1.06	1.08	1.1	1.14
22		0.71	0.8	0.87	0.93	0.97	1	1.06	1.08	1.1
24		0.62	0.71	0.8	0.87	0.93	0.97	1	1.06	1.08

Actual heating capacity calculation:

Actual heating capacity=amendment coefficient of heating capacity × nominal heating capacity

——Rated heating capacity could be found from **【Part 4 Specification】**

——amendment coefficient of heating capacity could be found from table above.

3. Long piping length

Cooling capacity (KBtu/h)		12K	18K	24K	30K	36K	42K	48K	60K
Connection Pipe(mm)	Liquid pipe	Φ6.35		Φ9.52			Φ9.52		
	Gas pipe	Φ12.7		Φ15.88			Φ19.05		
Max.piping length(m)		25	30	50		65			
Max.piping height(m)		10	20	25		30			
Max.Bend Qty		5		8		10			

Caution:

1. The standard Pipe length is 5m, if the pipe length is less than this then no additional charging is necessary. If the pipe length is more than this then you should charge more refrigerant into the system according to the above Charging Data
2. The thickness of the pipe is 0.6-1.0, bearing pressure is 4.2MPa;
3. If the connection pipe is too long, the cooling capacity and stability would be decreased. And the more bend quantity, the resistance in the piping system would be bigger, then the cooling and heating capacity would be decreased even lead to compressor broken. We suggest you to use the shortest connection pipe according to the pipe length parameter in this manual. If the height difference between outdoor and indoor unit is more than 5m, an oil trap should be installed in the gas pipe for every 10 meters.

4. Capacity amendment of different piping length

4.1 Amendment coefficients of heating and cooling capacity under different height drop

Different Cooling Capacity modified coefficients at different height:

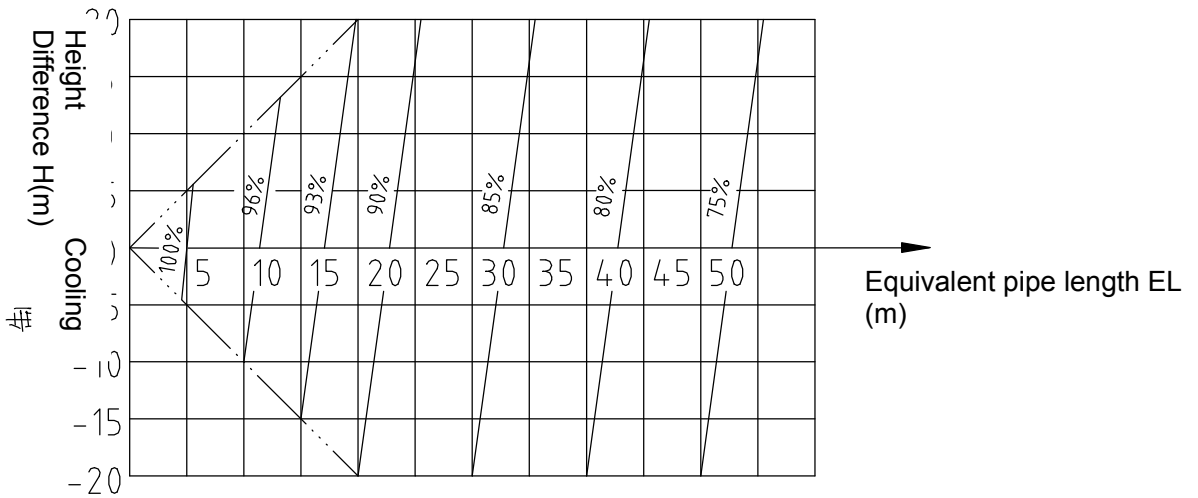

Note:

H = Height of Outdoor Unit - Height of Indoor Unit

Different Heating Capacity modified coefficients at different height:

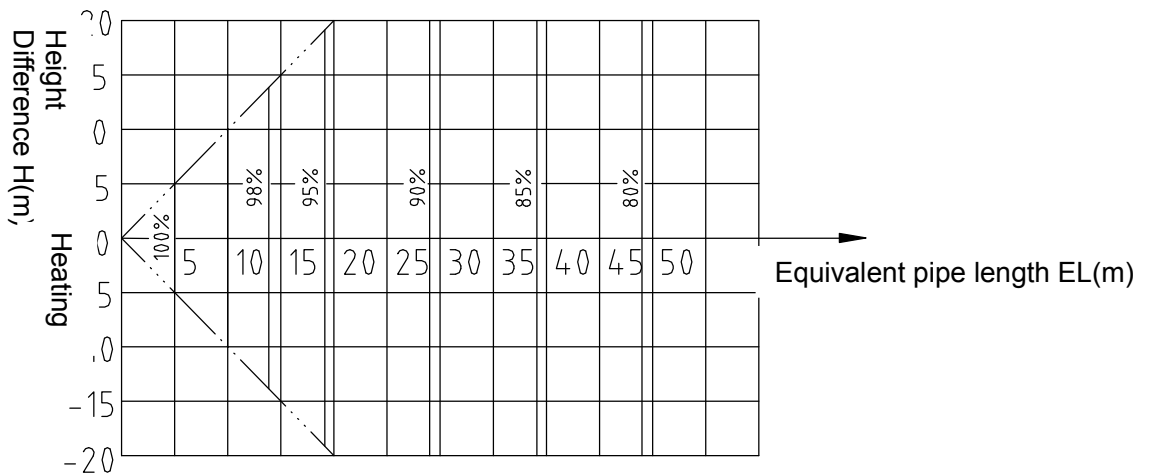

Note:

H = Height of Outdoor Unit - Height of Indoor Unit

4.2 Correction capability

Cooling capacity = Rated cooling capacity xK1xK3

Heating capacity = Rated heating capacity xK2xK3

5. Equivalent Pipe length conversion

Equivalent pipe length means converting pipe elbow to straight pipe length after considerate the pressure loss.

Bend and Oil Loop Conversion table

Type Pipe Dia.(mm)	Bend (m)	Oil Loop(m)
6.35	0.10	0.7
9.52	0.18	1.3
12.70	0.20	1.5
15.88	0.25	2.0
19.05	0.35	2.4
22.02	0.40	3.0

Equivalent Pipe length $L = \text{Actual Pipe length } L + \text{Bend Qty} \times \text{Equivalent pipe bend length} + \text{Oil Loop Qty} \times \text{Equivalent Oil Loop length}$

Sample:

ALCA-H42/5 Actual Pipe length is 25 meters, Gas pipe diameter is 15.88mm. If there's 5 bends and 2 oil loops during the installation, then the equivalent pipe length should be:

$$L = 25 + 0.25 \times 5 + 2.0 \times 2 = 30.25(\text{m})$$

Note:

If there is relatively level difference of indoor and outdoor unit, S-shaped oil trap must be installed every 8~10m for vertical pipe.

Part8 Static pressure curve

1. 18K Duct

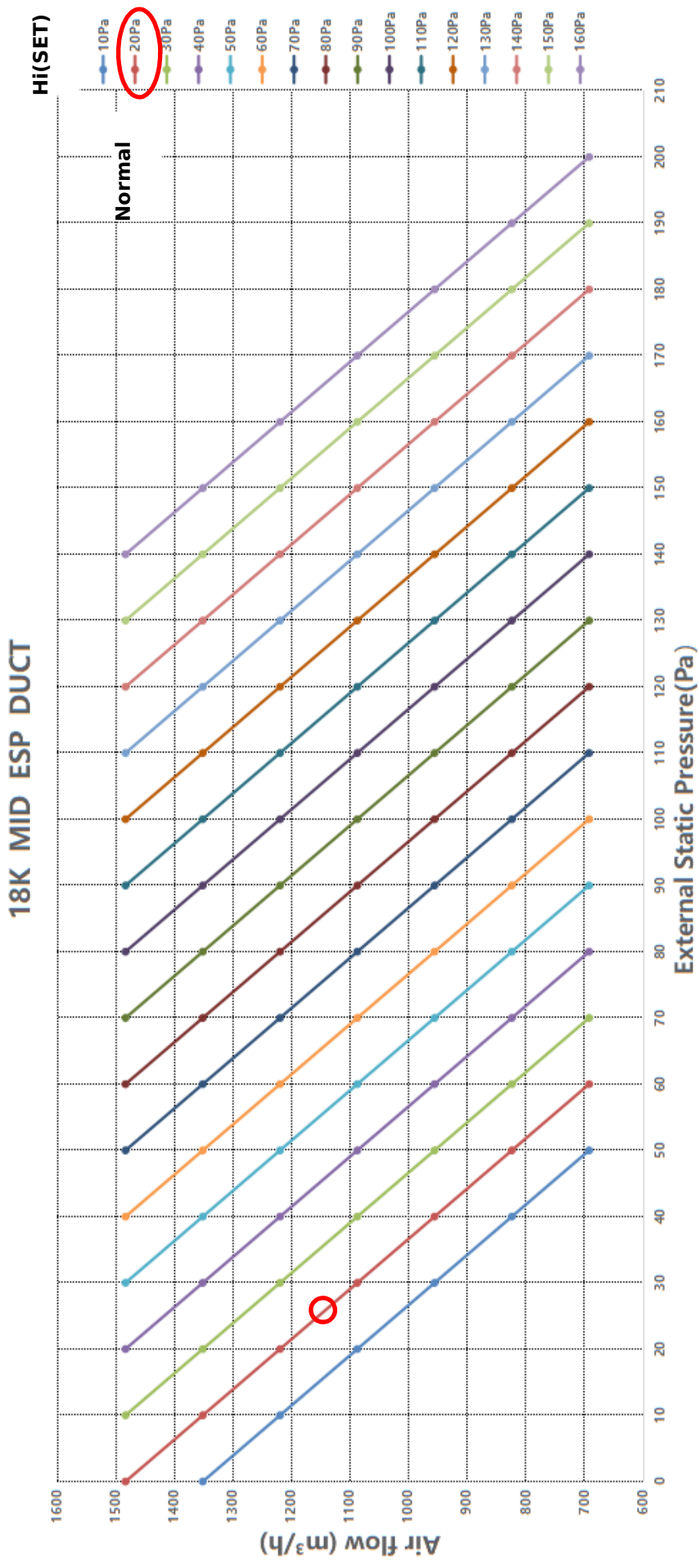

R32 High Efficiency DC Inverter LCAC

2. 24K Duct

24K MID ESP DUCT

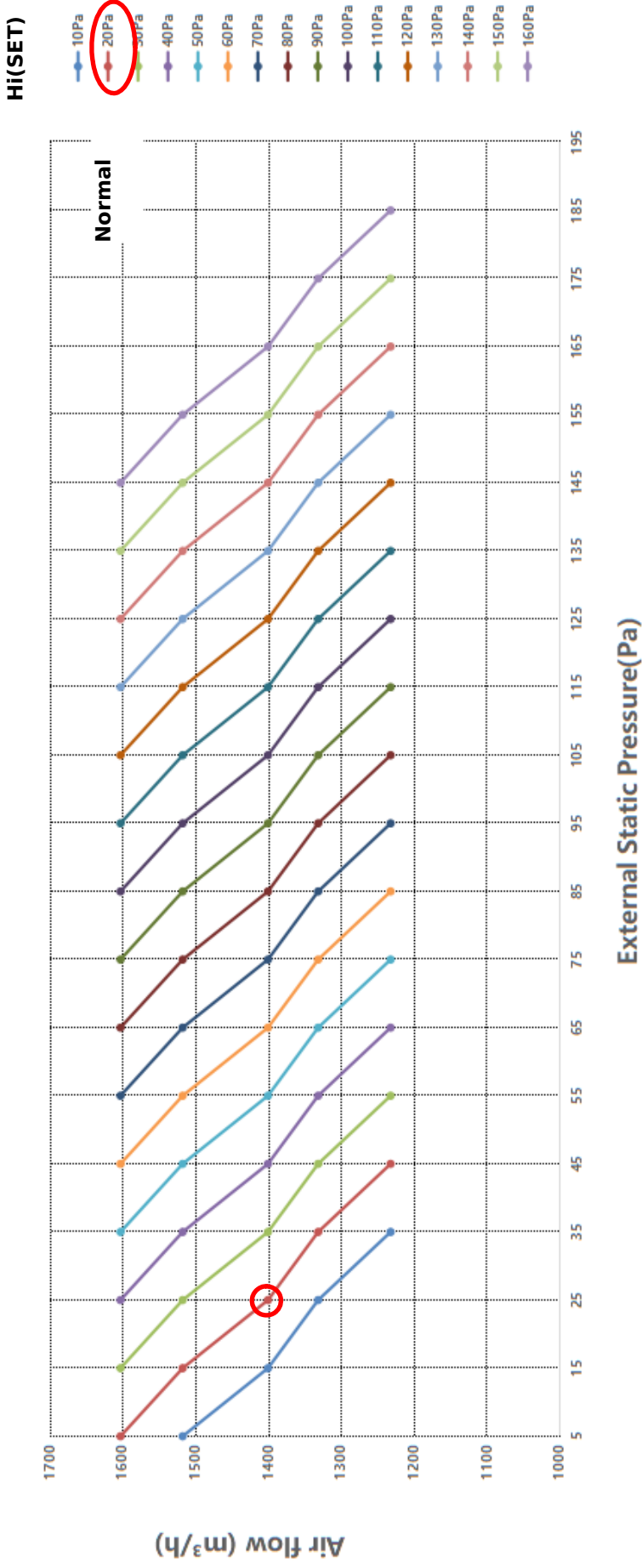

R32 High Efficiency DC Inverter LCAC

2. 30K Duct

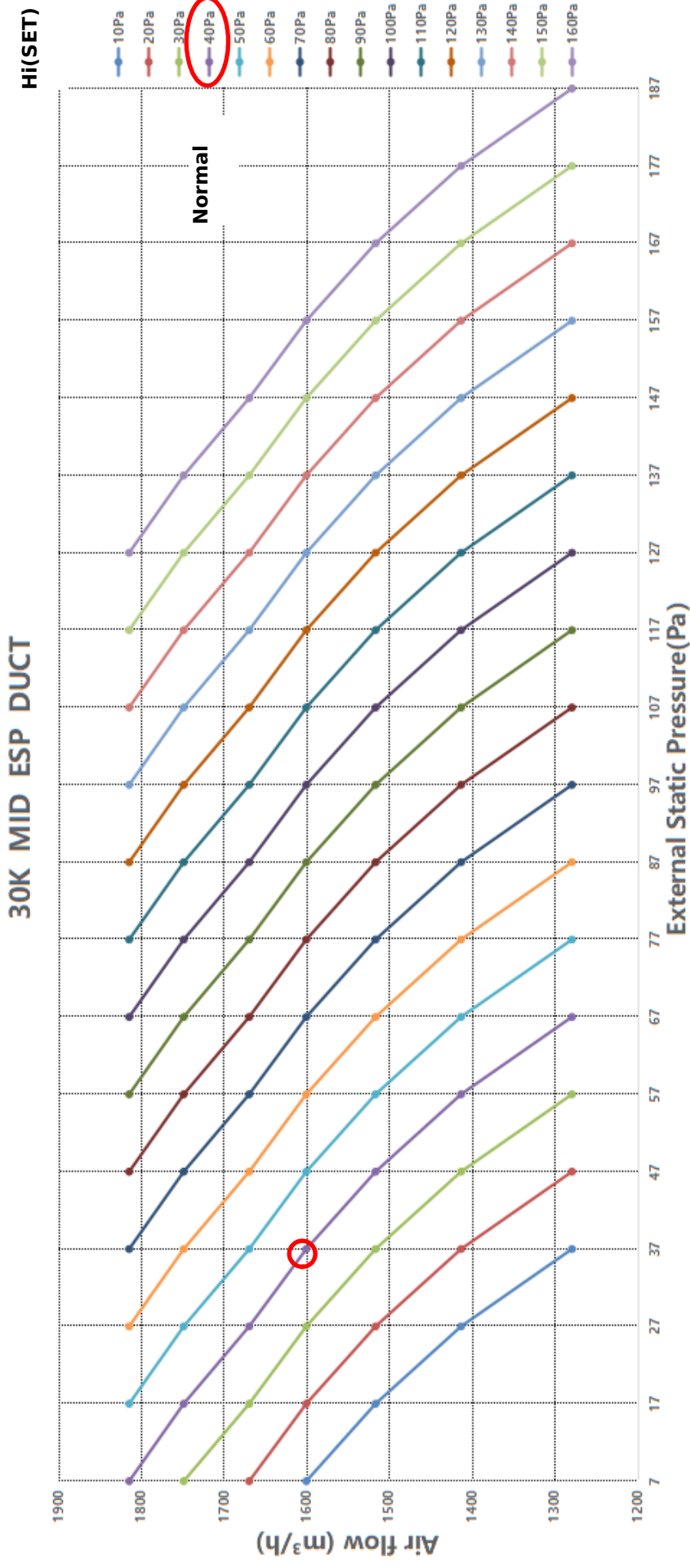

R32 High Efficiency DC Inverter LCAC

2. 36K/42K Duct

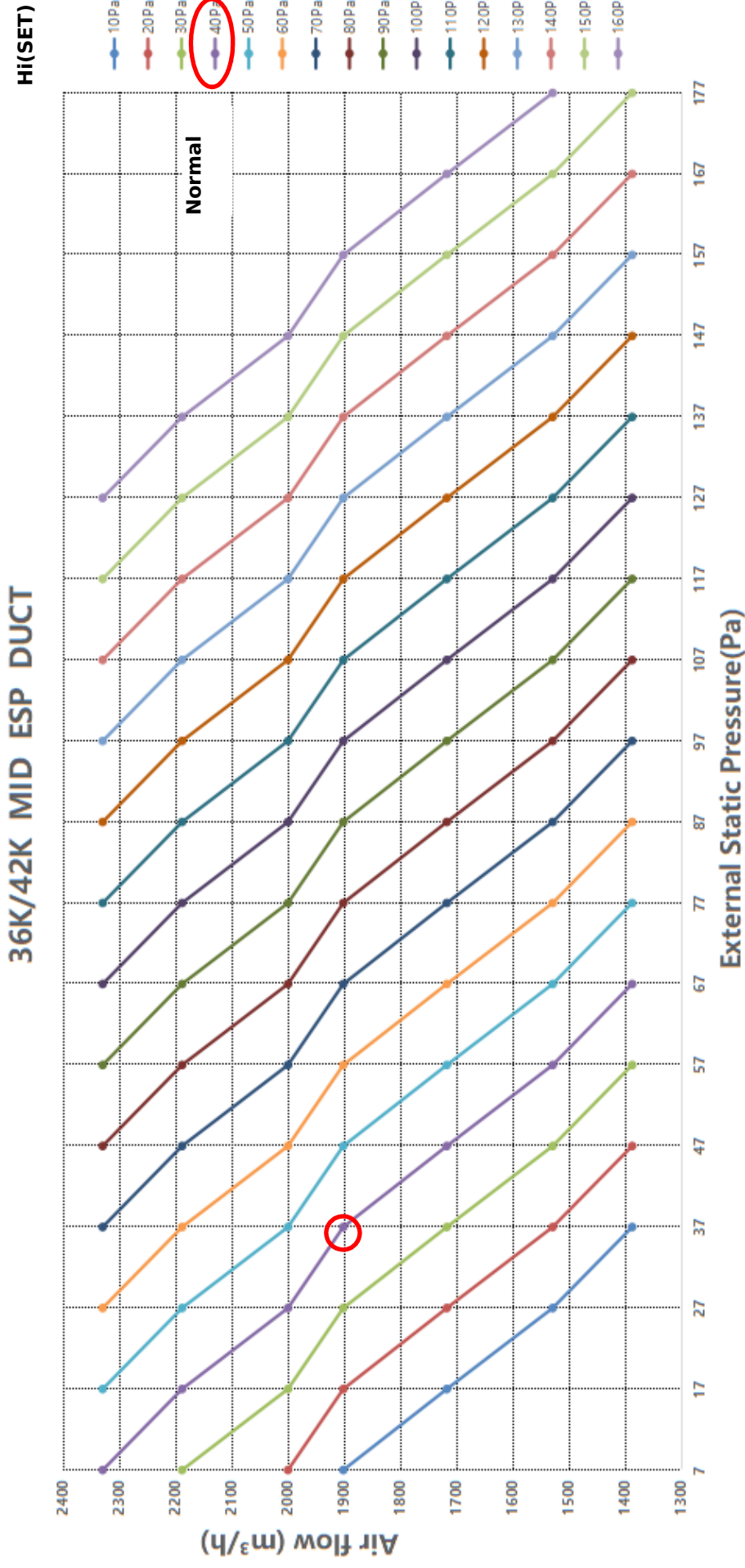





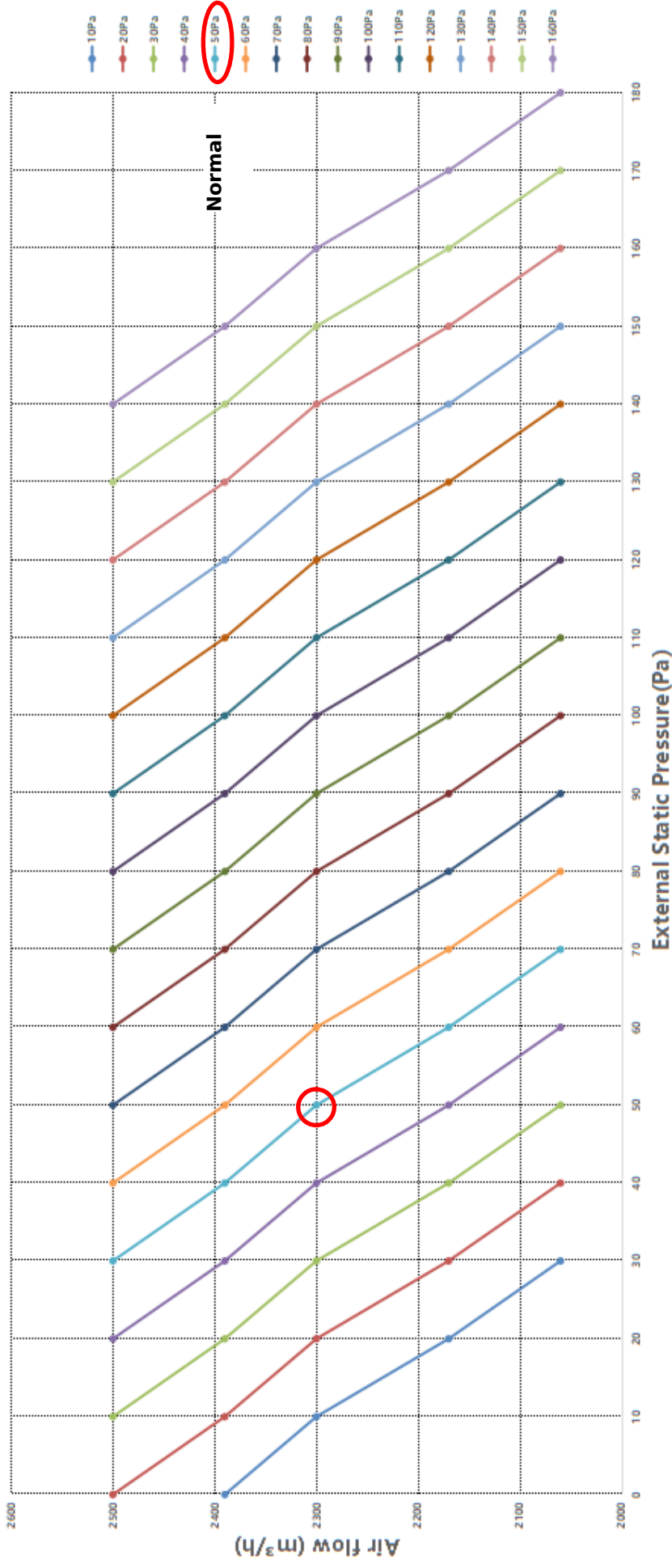

3. 48K/60K Duct

48K/60K MID ESP DUCT

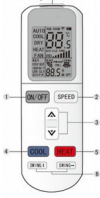

Part9 Control

1. Controller

IDU type	Controller	
	Standard	Optional
Cassette		
	<p>YK-L(AUX) 16422003000121</p>	<p>XK-04 11222020000034</p>
Ceiling Floor		
	<p>YK-L(AUX) 16422003000121</p>	<p>XK-04 11222020000034</p>
Duct		
	<p>XK05-DY(AUX)120 11222020000038</p>	<p>XK-04 11222020000034</p>

1.1 Remote Controller YK-L

Remote controller: L series (This remote controller is standard configuration.)

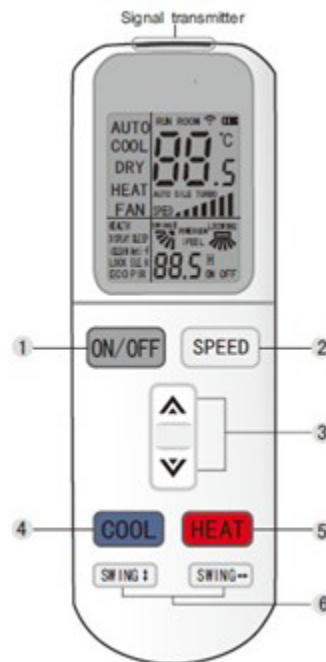

Note:

Remote controller outside buttons only valid when surface cover is closed.

Two white button is only for addressing set. If it has been set, remember not to reset by yourself.

1. “ON/OFF”button

*Press this button,the unit will start or stop,which can clear the timer or sleeping function orlast time.

2.“SPEED”button

*Press this button,speed will change as below:

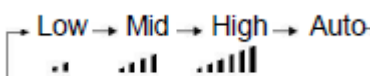

3.“▲/▼” button

*When press▲button, the setting temperature will be increased by 0.5°C.When press ▼button, the setting temperature will be decreased by0.5°C.

*The temperature will be changed quickly by pressing the button continuously and setting temperaturerangeis16°C to 32°C.

4.“COOL”button

*Press the **COOL** button,you can directly enter cooling mode.

5.“HEAT”button

R32 High Efficiency DC Inverter LCAC

* Press the **HEAT** button, you can directly enter cooling mode.

* **Note:** cooling only unit has no heating function.

6. “SWING” button (SWING←→and SWING↑↓)

Press this button to start up/down (left/right) swing function, press it again, fix louver position.

* Up/down (left/right) setting is only valid in this mode; it will not affect louver position in other modes.

* Up/down (left/right) swing has memory function, it can keep primary setting when turn off then turn on or switch from other modes to primary mode.

7. “HEALTH” button

* Press this button; you can turn on or off the health function.

8. “SLEEP” button

* Press SLEEP button, the sleeping indicator light of indoor unit flashes on.

* The air-conditioner runs in sleeping mode for 10 hours and quiet sleep mode, recover back to former mode.

* The unit will turn off automatically if the timing mode is running out of time.

* Note: press the MODE or ON/OFF button, the remote controller clears sleeping mode away.

9. “iFEEL” button

* Press this button to set “iFEEL” function. The LCD shows the actual room temperature when the function set and it shows the setting temperature when the function can be called.

* This function is invalid at Fan mode.

10. “DISPLAY” button

* In display mode, press button once, switch off “DISPLAY”, Press “DISPLAY” again, LCD will show ambient & setting temperature after flashing 5s. It's convenient for users to check ambient or setting temperature at any time in darkness.

11. “iCLEAN” button

* When remote controller is at the off state, press this button, the unit runs “iCLEAN” function.

* The purpose of this function is to clean dust on evaporator and dry the inside water of evaporator and to prevent the evaporator going moldy due to water deposition and boasting strange smell.

* After setting “iCLEAN” function, press “iCLEAN” button or “ON/OFF” button to quit.

R32 High Efficiency DC Inverter LCAC

* The clean function will stop working after about 30 minutes running without any operation.

12. “ELE.H” button (for auxiliary electric heating IDU)

In heating mode, press this button, auxiliary electric heating will work.

13. “Anti-FUNGUS” button

* The purpose of this function is to dry the inside of the evaporator and to prevent the evaporator from going mouldy due to water deposition and thus dispersing strange smell.

14. “SPOTSWING” button

* Press this button, the horizontal wind direction vanes can swing automatically, when you have the desired vertical wind direction.

* Press “SPOT SWING” again, the horizontal wind direction vanes will best opened depend on you.

15. “ECO” button

* In cooling mode, press this button, the unit will run “ECO” economic operation mode which takes the least power consumption.

* After running for 8h, it will automatically quit. You can press “ECO” button once again to quit.

* Note: The unit will turn off automatically if the timing mode is running out of time.

16. Two white button: Addressing set

* With the controller off, pressing the two white button simultaneously more than 10 seconds or more to enter address setting. This status displays only temperature and time parameters, temperature display area shows “Serial number” parameters, the range is 0-99. Time display area shows “Set value”, the range is 0-255. The initial value is 1.

* By pressing “▲/▼” to set serial number + and -. Parameter within the serial number displays from 0 to 99 in circulation.

* By pressing “ECO” and “iCLEAN” to set value number + and -. Parameters within the value number displays from 0 to 255 in circulation. After setting the two numbers, press the MODE button to confirm sending to ODU.

R32 High Efficiency DC Inverter LCAC

1.2 Wired Controller XK-05/XK-04

XK-05	Features
 <p>The image shows the AUX XK-05 wired controller. It is a square-shaped device with a white faceplate. At the top, the brand name 'AUX' is printed. Below it is a small LCD screen displaying '25 °C'. Underneath the screen are eight touch-sensitive buttons arranged in two rows. The top row contains buttons for 'TIMER', 'FAN', 'SWING', and 'MODE'. The bottom row contains buttons for 'FUNCTION', an up arrow, a down arrow, and 'ON/OFF'.</p>	<p>Technical indicator</p> <ol style="list-style-type: none"> 1. Power source:voltage DC 12V; 2. Work temperature range of PCB:(-10~+70)°C; 3. Work humidity range of PCB:RH20%~RH90%; 4. Button: Touch button 5. Dimensions(W*H*D):120*120*20mm <hr/> <p>Main functions</p> <ol style="list-style-type: none"> 1. 8-keytouch button input 2. Buzzer prompt tone function 3. LCD+ white backlight 4. Display the failure of main controller 5. Ambient temperature detection sensor 6. Receive the signal of wireless remote controller

XK-04	Features
 <p>The image shows the AUX XK-04 wired controller. It is a square-shaped device with a white faceplate. At the top, the brand name 'AUX' is printed. Below it is a small LCD screen displaying '26 °C'. Underneath the screen are nine touch-sensitive buttons arranged in two rows. The top row contains buttons for 'Timer', 'Fan', 'Swing', and 'Mode'. The bottom row contains buttons for 'Function', an 'ON/OFF' button, a down arrow, and 'Comfort'.</p>	<p>Technical indicator</p> <ol style="list-style-type: none"> 1. Power source:voltage DC 12V; 2. Work temperature range of PCB:(0~50)°C; 3. Work humidity range of PCB:RH20%~RH90%; 4. Button: Touch button 5. Dimensions(W*H*D):86*86*10.8mm <hr/> <p>Main functions</p> <ol style="list-style-type: none"> 1. 9-keytouch button input 2. Buzzer prompt tone function 3.Comfort one-button setting 4. LCD+ white backlight 5. Display the failure of main controller 6. Ambient temperature detection sensor 7.Connect to indoor unit via 3 (4) -core shielded cable 8. Receive the signal of wireless remote control

XK-05

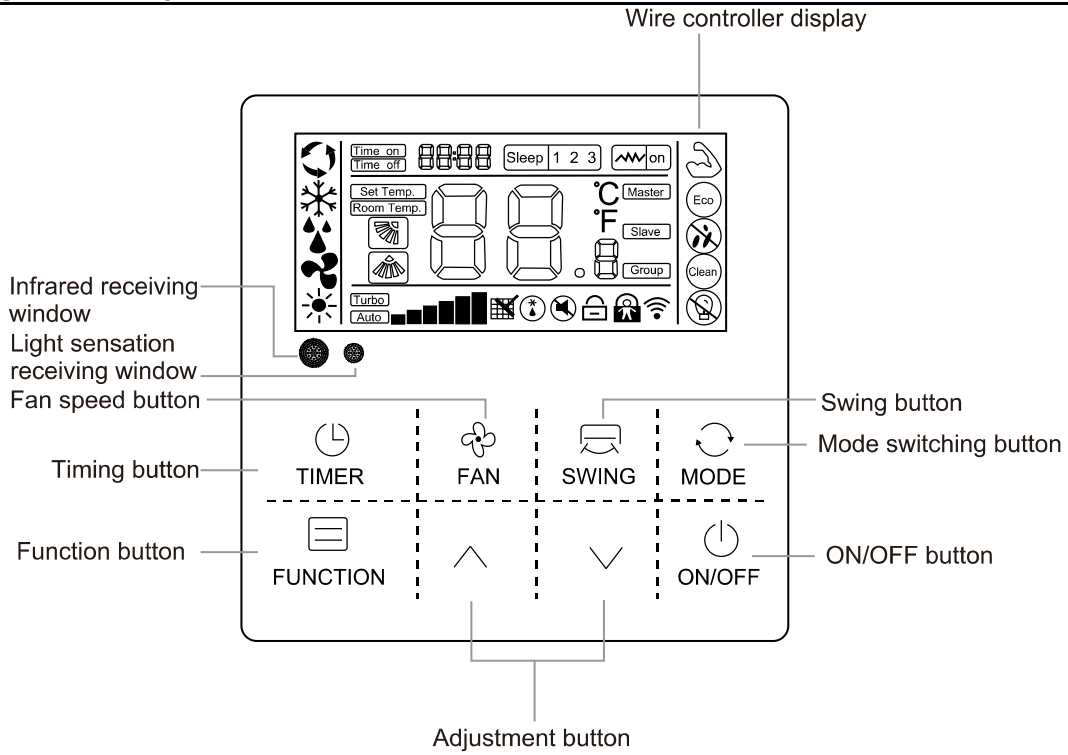

XK-04

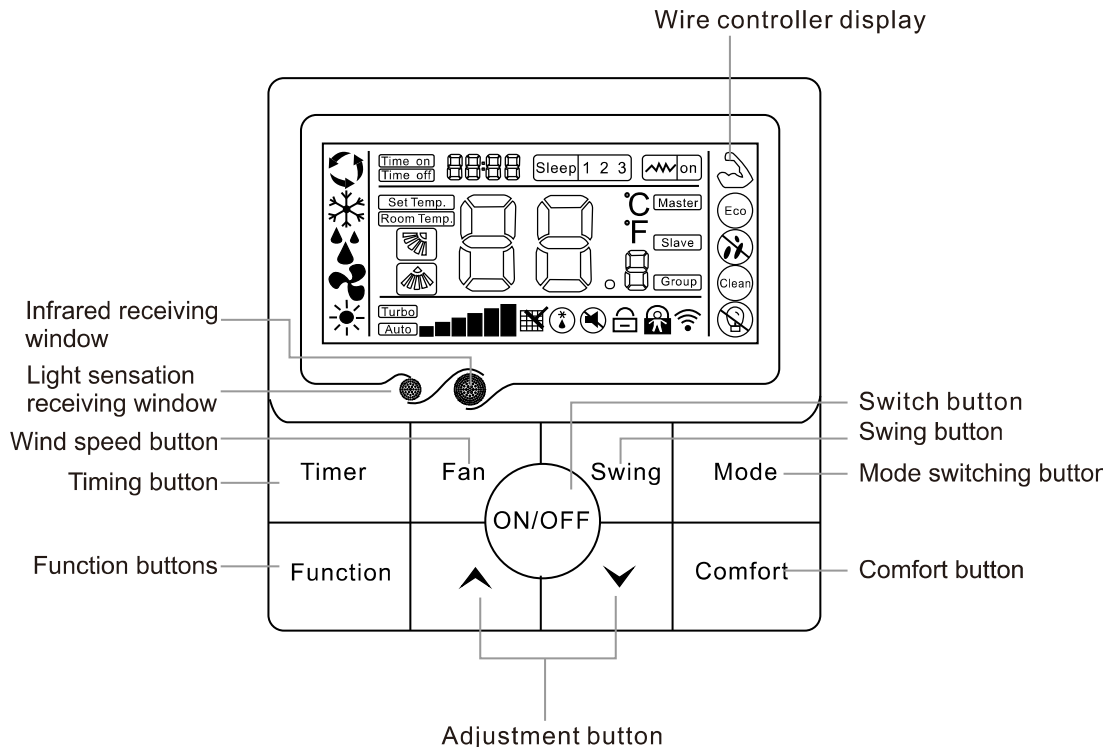

Detailed operation instructions (6)

1. 【 ON/OFF button 】

R32 High Efficiency DC Inverter LCAC

Press- "ON / OFF" button to start or shutdown the unit.

1.1. When the unit is running, users can regulate the operation mode, fan speed, setting temperature, special functions and other parameters on the wired controller

XK-05

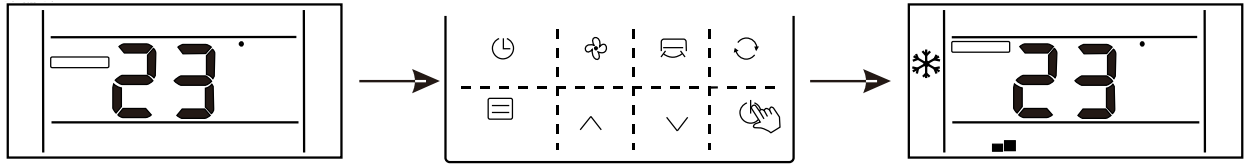

XK-04

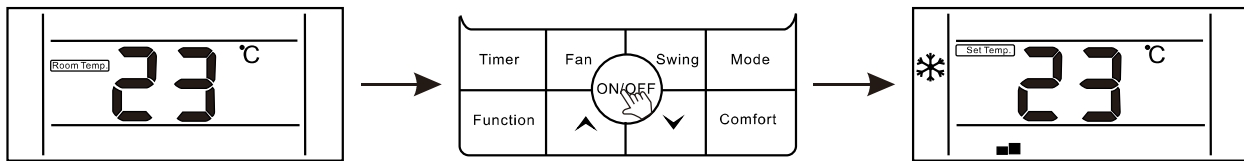

2. When the unit is standby, the wire controller displays indoor ambient temperature (Room temp.), the other content are not displayed.

XK-05

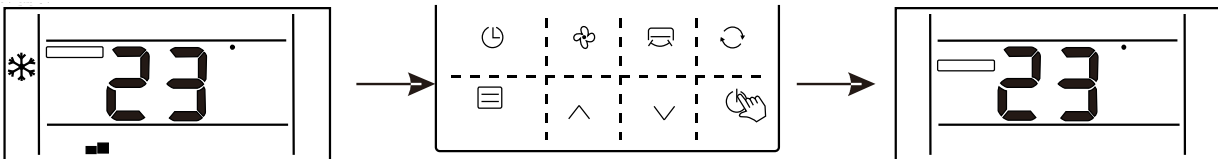

XK-04

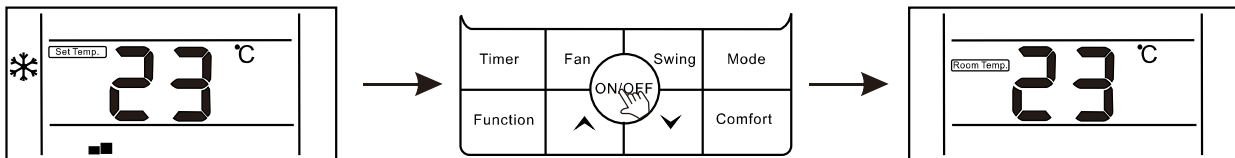

2. [▲ / ▼ button]

2.1. When the unit is running, press " ▲ " or " ▼ " button to increase or decrease the setting temperature by 1°C. Under COOL, DRY, and HEAT modes, the setting temperature range is 16 °C ~ 32 °C ; The controller will display " Set temp." to show the setting temperature;

XK-05

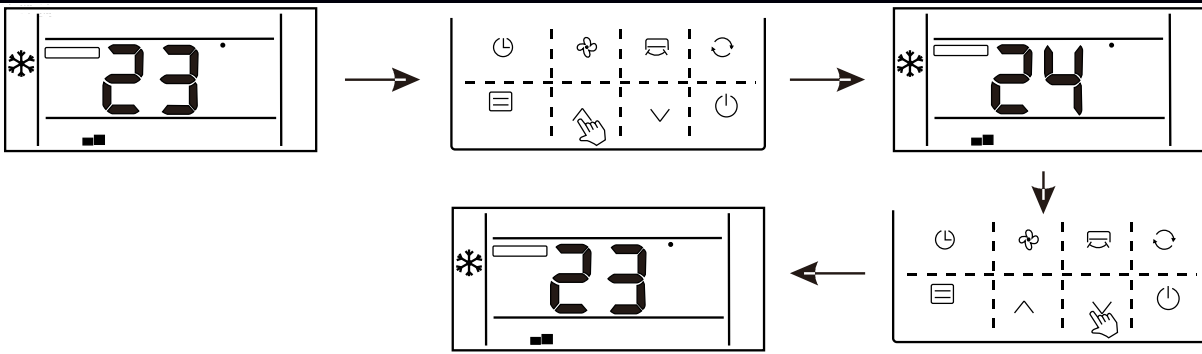

XK-04

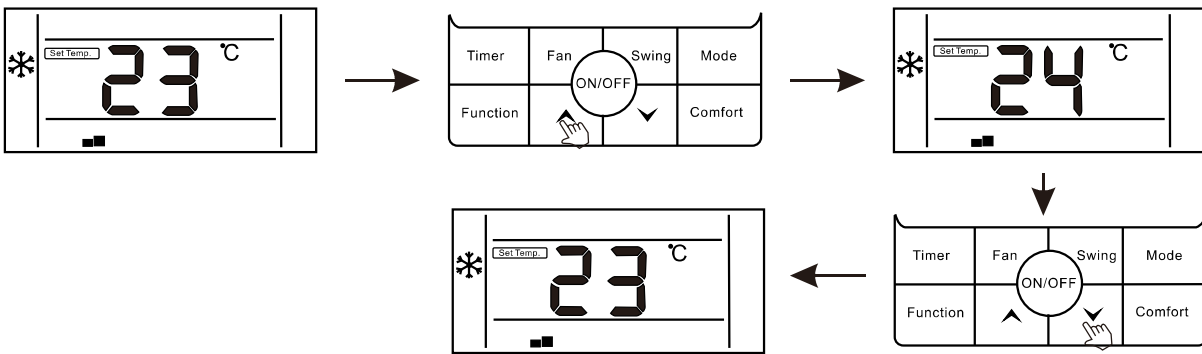

2.2. Under the function selection mode, press "▲" or "▼" button to select a function;

2.3. Under the timing mode, press "▲" or "▼" button to setting time.

3. 【 Mode button 】

When the unit is running, press "MODE" button, the running mode will switch according to the following order.



The initial setting temperature for each mode is 24 ° C, and there is no temperature setting and automatic wind under FAN mode.

4. 【 "Fan" button 】

When the unit is running, press "Fan" button to switch fan speed in the following order:

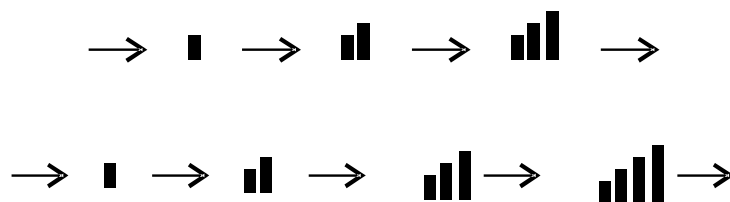

5. 【 "Swing" button 】

5.1. For the unit only has the function of up and down swing:

R32 High Efficiency DC Inverter LCAC

when the unit is running, press "Swing" button to enter or cancel up and down swing.

At the time of opening up and down swing, " " is lighting. At the time of closed, swing icon will disappear. If the unit has positioning swing function, press "Swing" button to regulate the swing angle in the order

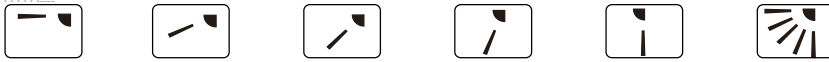

5.2. For the unit only has the function of left and right swing:

when the unit is running, press "Swing" button to enter or cancel left and right swing. At

the time of opening left and right swing, " " is lighting. At the time of closed, swing icon will disappear. If the unit has positioning swing function, press "Swing" button to regulate the swing angle in the order



5.3. For the unit has the functions of left and right swing and up and down swing:

Press "Swing" button, the swing mode will switch in the following cycle order:

≡ . ≡

6. 【 "Timing" button 】

Users can set shutdown timing time when the unit is running, and set starting-up timing time when the unit is standby.

6.1. Press Timer button when the unit is running, the wired controller will display " " and users can set the shutdown timing time; when the unit is standby, the wired controller will display " " , and users can set the starting-up timing time

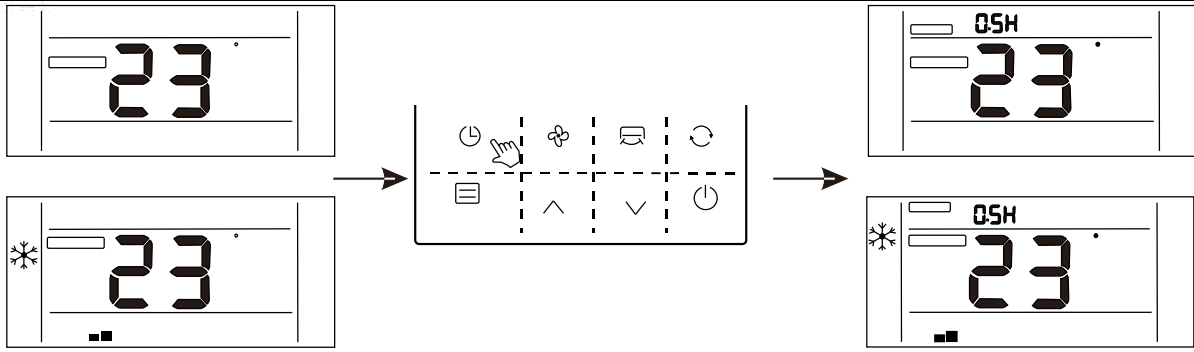

XK-04

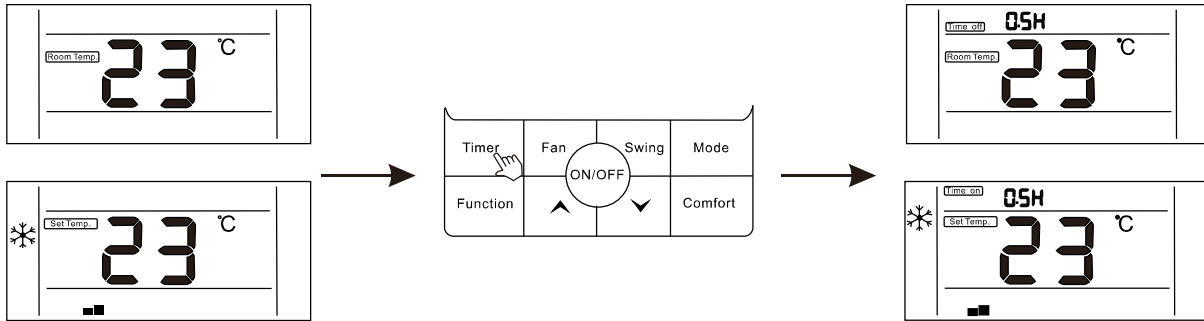

6.2. After entering timing time setting interface, the default timing time is 0.5H, at this moment, press "▲" or "▼" button to regulate the timing time. If the button is not pressed for 10 seconds, the timing setting will be canceled, and then return to the state of non-timing.

XK-05

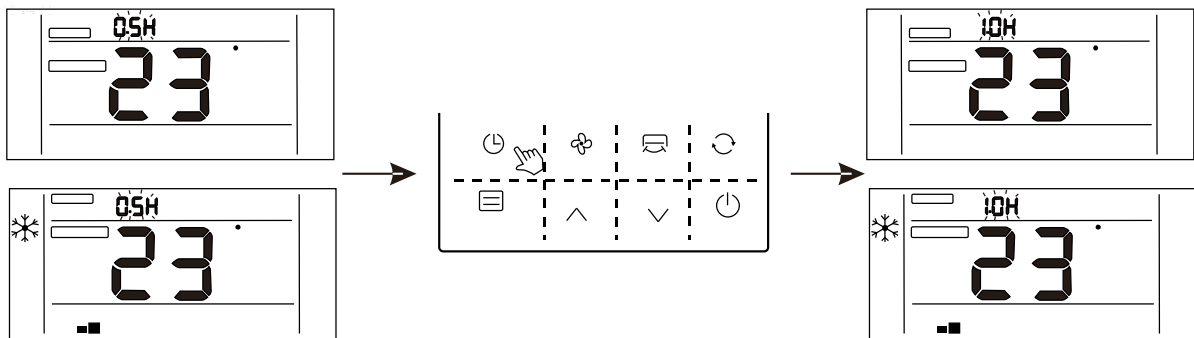

XK-04

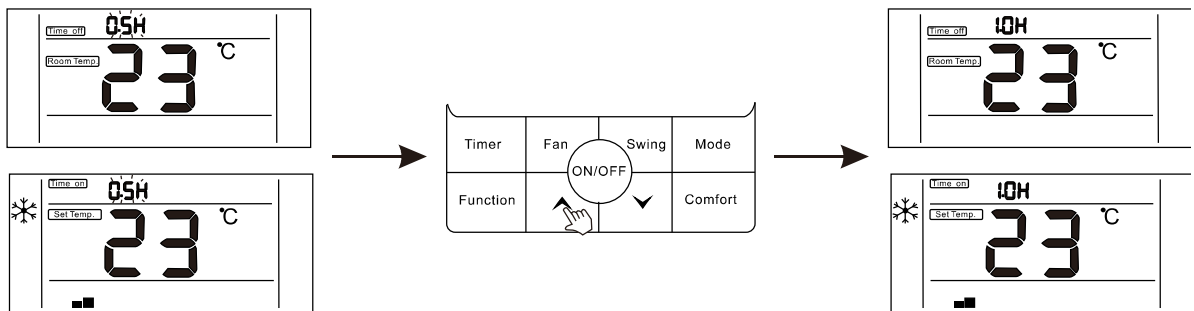

6.3. After the setting of timing, press "Timer" button again to confirm. The timing setting is

R32 High Efficiency DC Inverter LCAC

successful and the time bar will stop blinking.

XK-05

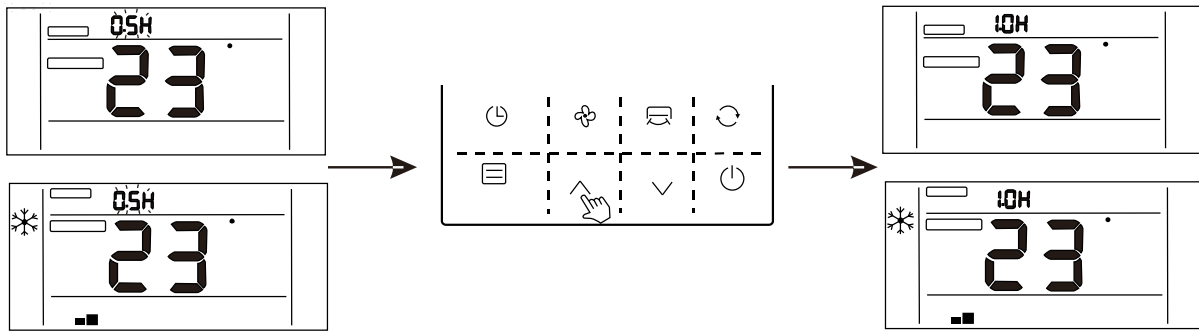

XK-04

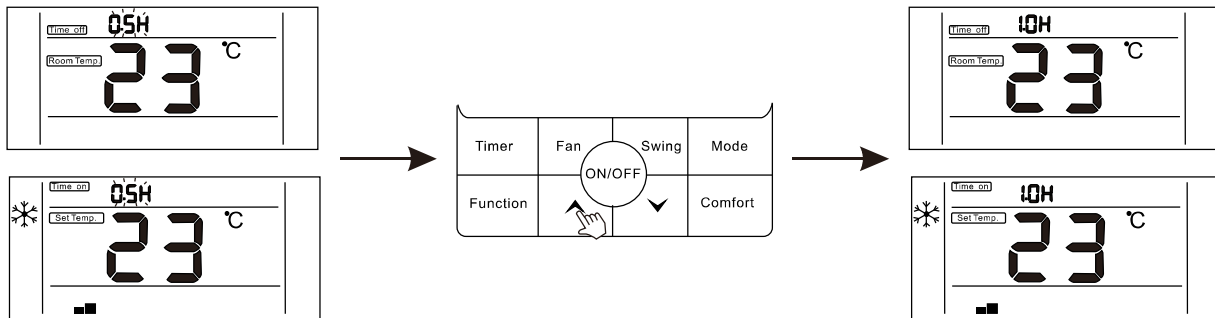

6.4. After the setting "Timer On" function, you can adjust the fan speed, running mode, set temperature, and swing angle. If there is no operation for 10 seconds, standby screen will be displayed.

XK-05

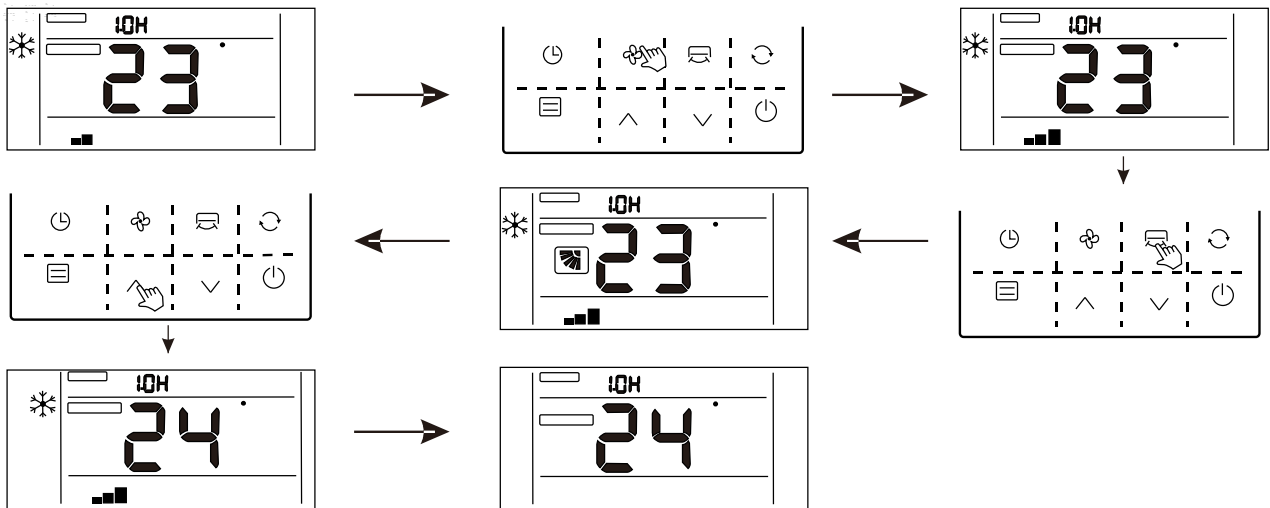

XK-04

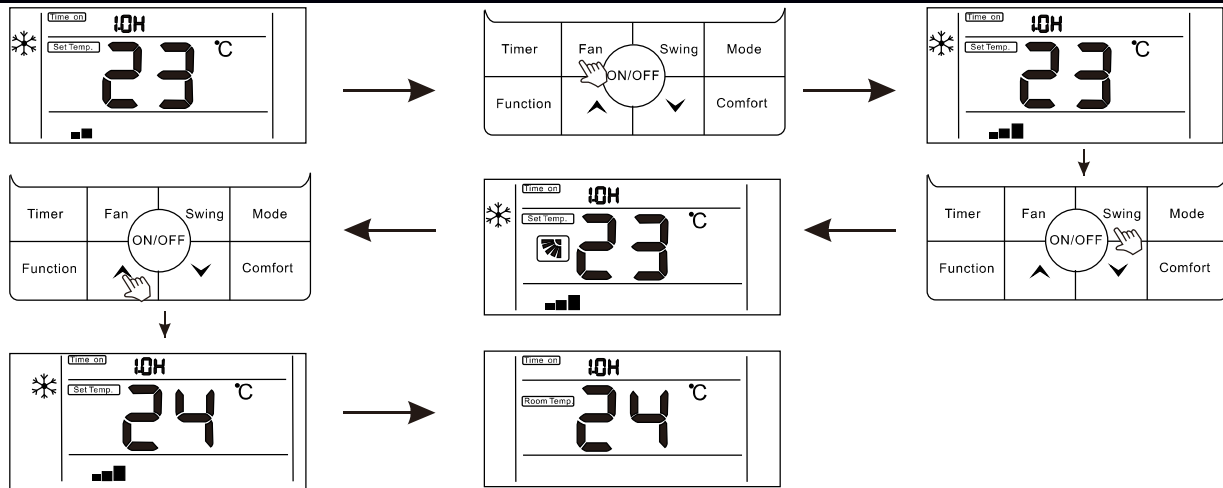

6.5. Timing range: 0.5 ~ 24 hours.

press "▲" or "▼" button once, the timing time will increase or decrease by 0.5 hours. When the timing time is more than 10 hours, press "▲" or "▼" button once, the timing time will increase or decrease by 1 hour.

6.6. Press "Timer" button or "ON / OFF" button to exit Timer ON or Timer OFF.

Function description (6)

The wire controller is for the general-purpose, specific functions for the controller are subject to the functions of your air conditioning unit.

Note: In the interface of function setting, press any button such as Timer, Fan, Swing, Mode, ON/OFF, and Comfort to exit the interface and conventional operation interface will display. If there is no operation for 10S, you can exit the interface.

Enter function: Press function button to enter function selection interface, press "▲" or "▼" button to select a function, and the corresponding icon will flash, press "function" button again to confirm the function.

Cancel function: Press function button to enter function selection interface, press "▲" or "▼" button to select a function, and the corresponding icon will flash, press "function" button again to cancel the function.

1. ["Turbo"]

Turbo function: The fan speed will be ultra-high in turbo mode and users can achieve rapid cooling or heating effect.

Enter turbo function:

1. When the unit is running in cooling or heating mode, press "Function" key to enter the interface of function selection.

R32 High Efficiency DC Inverter LCAC

2. Press "▲" or "▼" button to switch to turbo function, at this moment, "👉" icon is flashing.

3. Press Function button to confirm turbo function, at this moment, icon "👉" fan speed display is () and highest fan speed icon).

XK-05

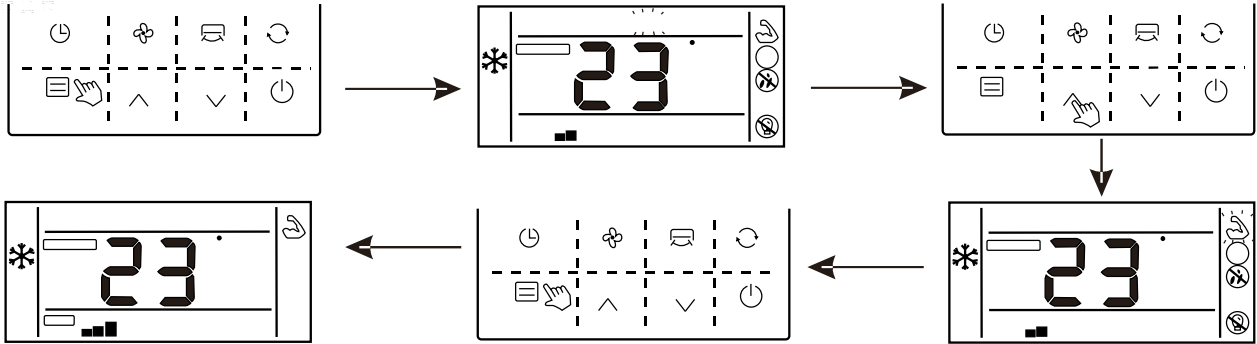

XK-04

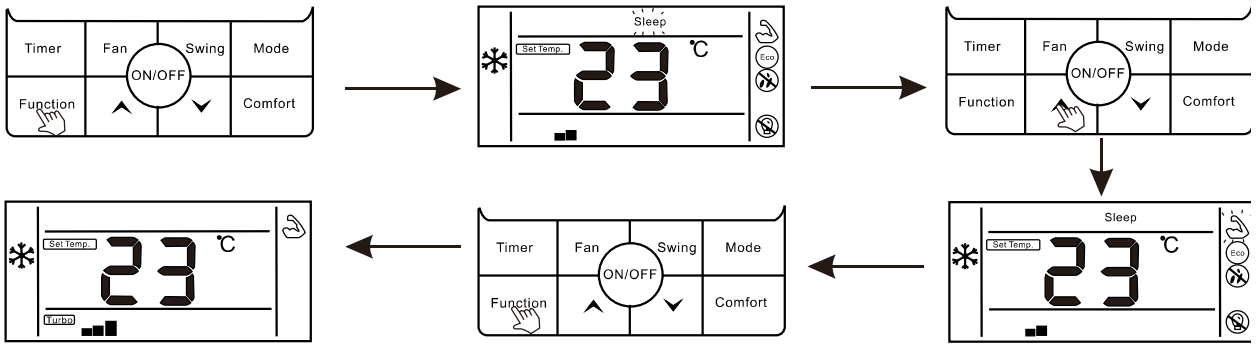

Cancel turbo function:

1. When turbo function is opened, press "Function" button to enter the interface of function selection.

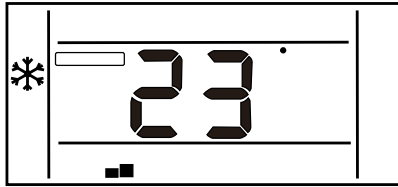
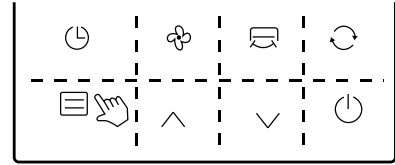
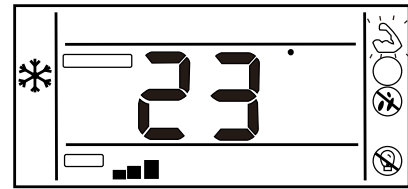
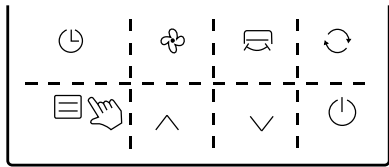

2. Press "▲" or "▼" button to switch to strong function, at this moment, icon "👉" is flashing, press Function button to cancel strong function, and strong icon would not display

XK-05

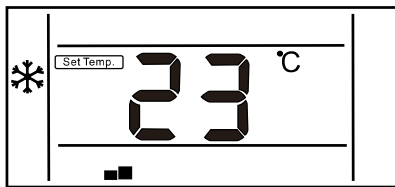
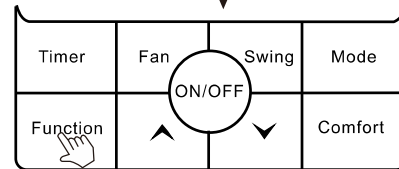
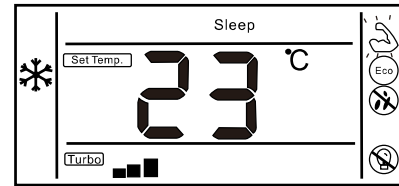
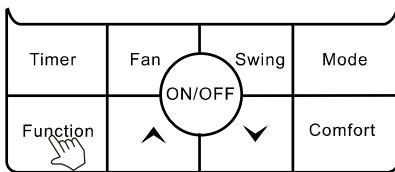

XK-04







Note: The unit without turbo function can also set turbo function on the wired controller, the performance is high fan speed, but "  " icon and "  " icon do will not display.

2. 【 "Sleep" 】

Sleep function: Make indoor unit will run according to pre-set sleep temperature curve, which creates a comfortable sleep environment and improves sleep quality

Enter sleep function:

1. In the state of running, press "Function" button to enter the interface of function selection.
2. Press "  " or "  " button to switch to sleep function, "  " icon is flashing at this moment
3. Press " Function " button to open sleep function, at this moment, icon "  " is lighting

XK-05

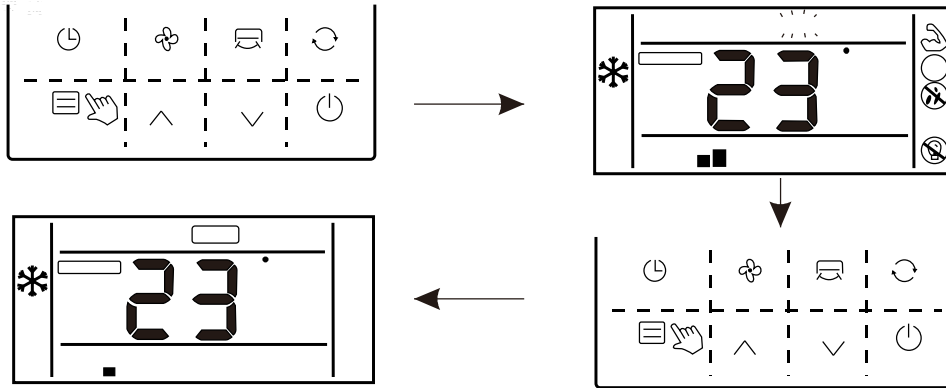

XK-04

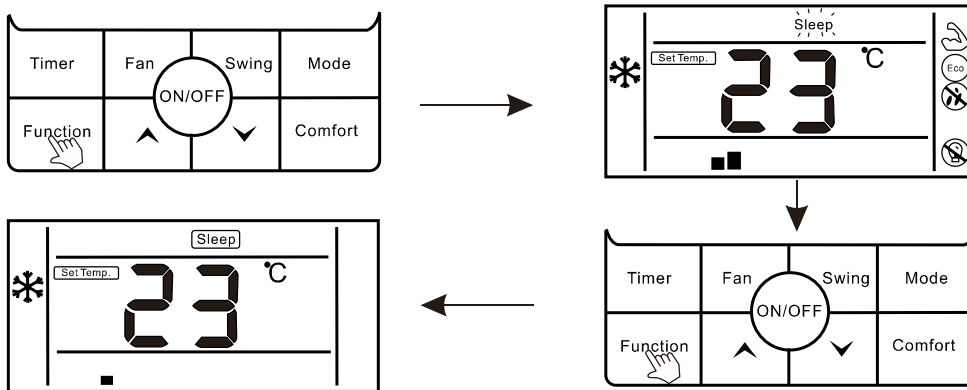

Cancel "sleep" function:

1. In the state of running, press "Function" button to enter the interface of function selection.
2. Press "▲" or "▼" button to switch to sleep function, "  " icon is flashing
3. Press "Function" button again to cancel sleep function

XK-05

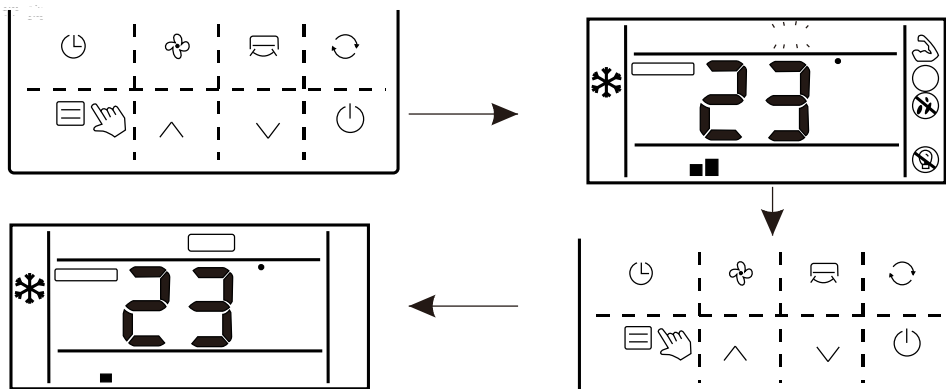

XK-04

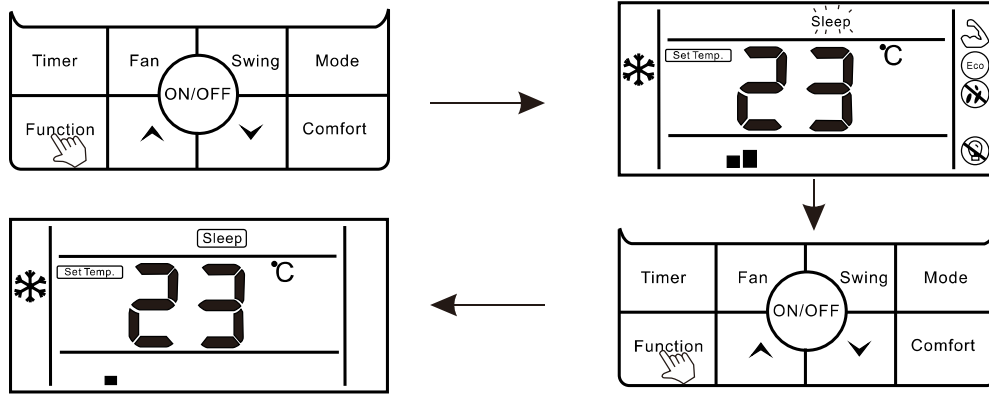

3. ["ECO"]

Enter ECO function:

1. Press "Function" button to enter the interface of function selection.
2. Press "▲" or "▼" button to switch to ECO function, at this moment "○" icon is flashing
3. Press "Function" button again to confirm ECO function, at this moment, "○" icon is lighting

XK-05

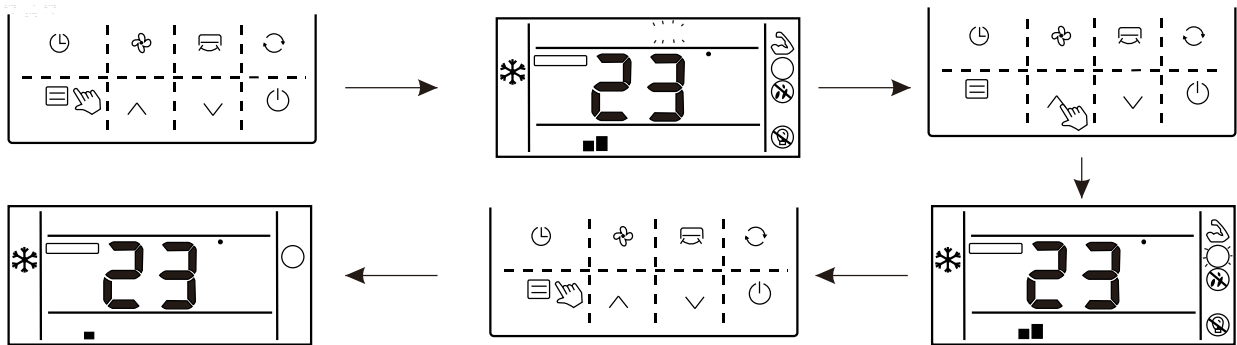

XK-04

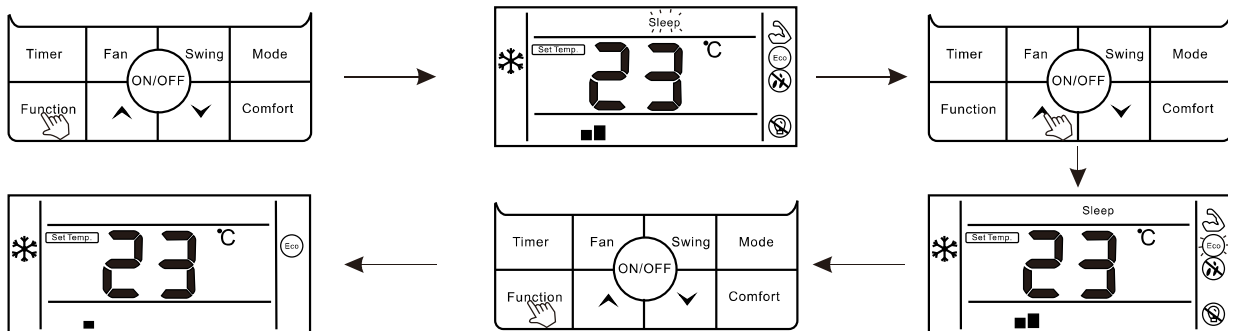

Cancel ECO function:

R32 High Efficiency DC Inverter LCAC

1. Press "Function" button to enter the interface of function selection.

2. Press "▲" or "▼" button to switch to ECO function, at this moment "☉" icon is flashing

3. Press "Function" button again to cancel ECO function

XK-05

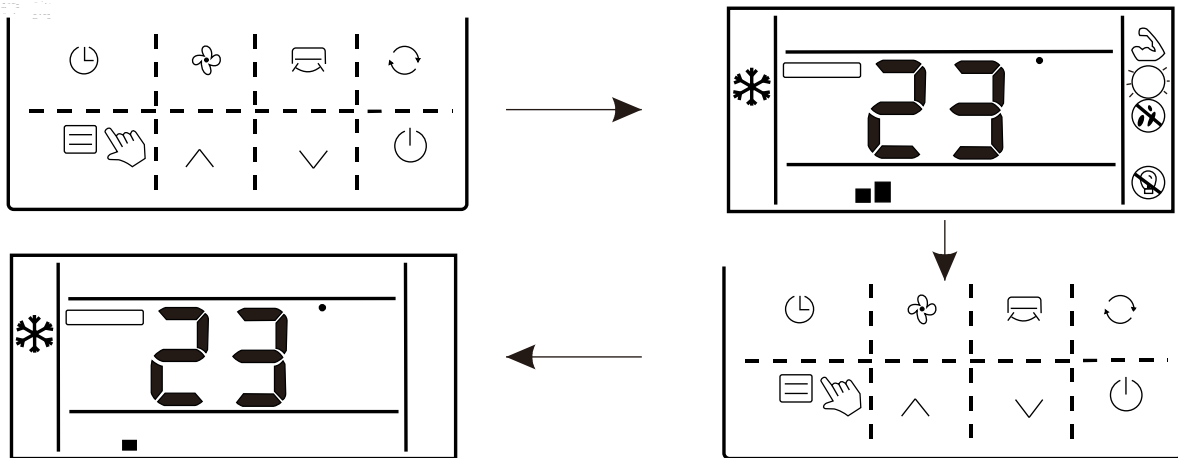

XK-04

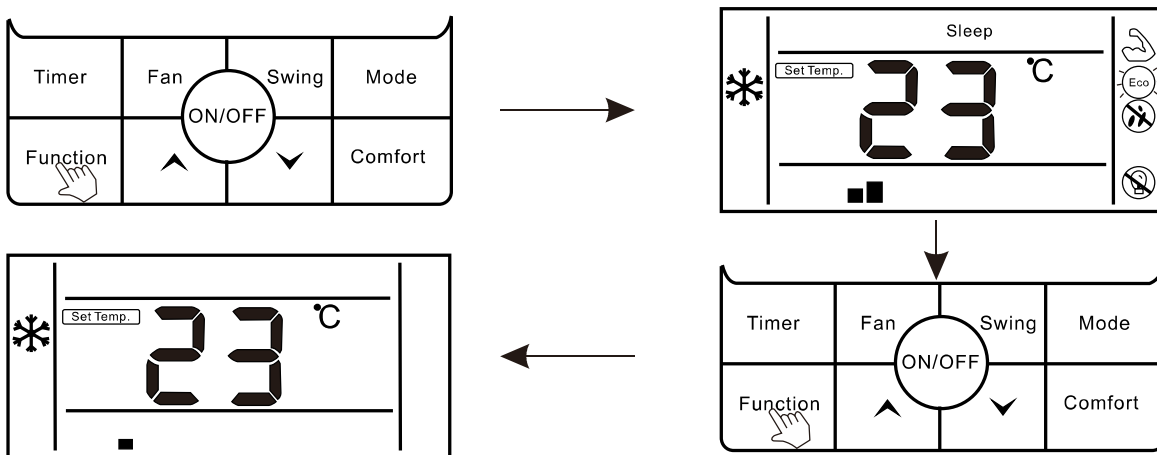

4. 【 "Mildew-proof" 】

Mildew-proof function: After shutdown, the air conditioner would automatically dry the moisture in the evaporator of indoor unit, so as to avoid mildewing.

Enter mildew-proof function:

1. Under COOL and DRY mode, press "Function" button to enter the interface of function selection

2. Press "▲" or "▼" button to switch to the mildew-proof function setting interface, at this moment, icon "☉" is flashing;

3. Press "Function" button again to enter mildew-proof function, icon "☉" is lighting.

XK-05

R32 High Efficiency DC Inverter LCAC

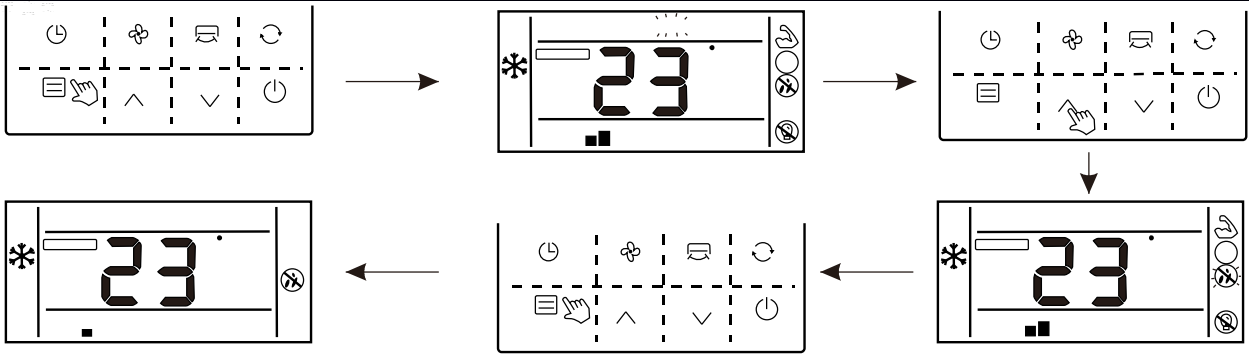

XK-04

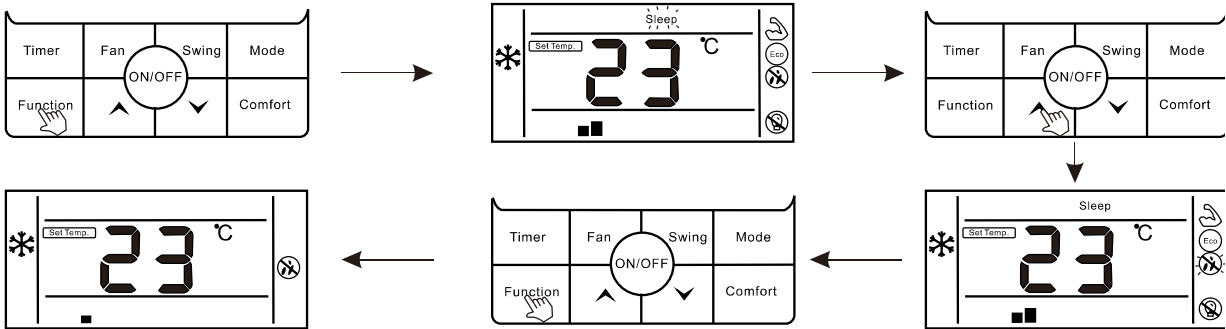

Cancel fungus-proof function:

1. When mildew proof function is ON, press "Function" button to enter the interface of function selection
2. Press "▲" or "▼" button to mildew-proof function icon "❄️" is flashing;
3. Press "Function" button again to cancel mildew proof function, icon will "❄️" disappear

XK-05

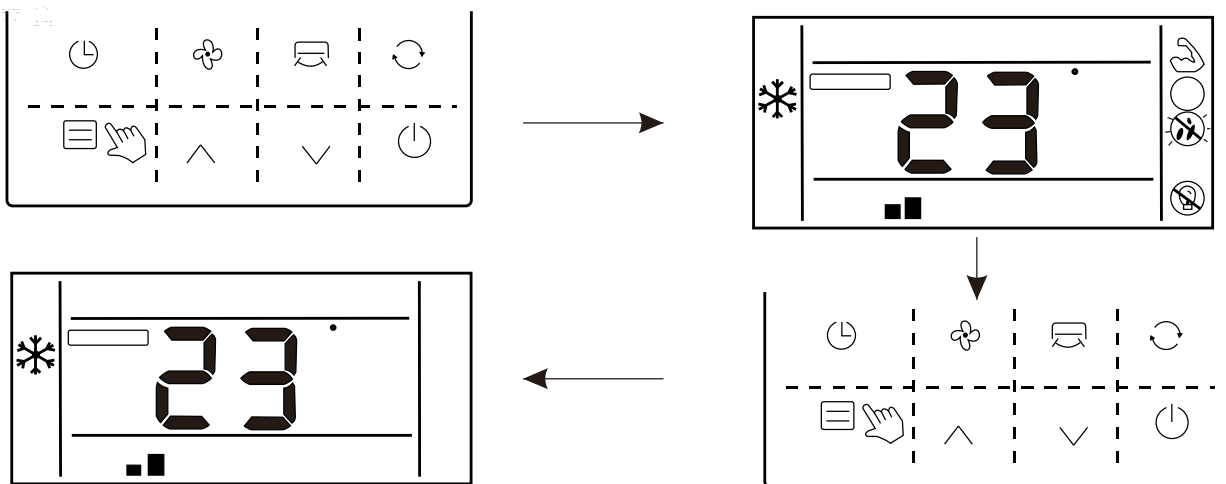

XK-04

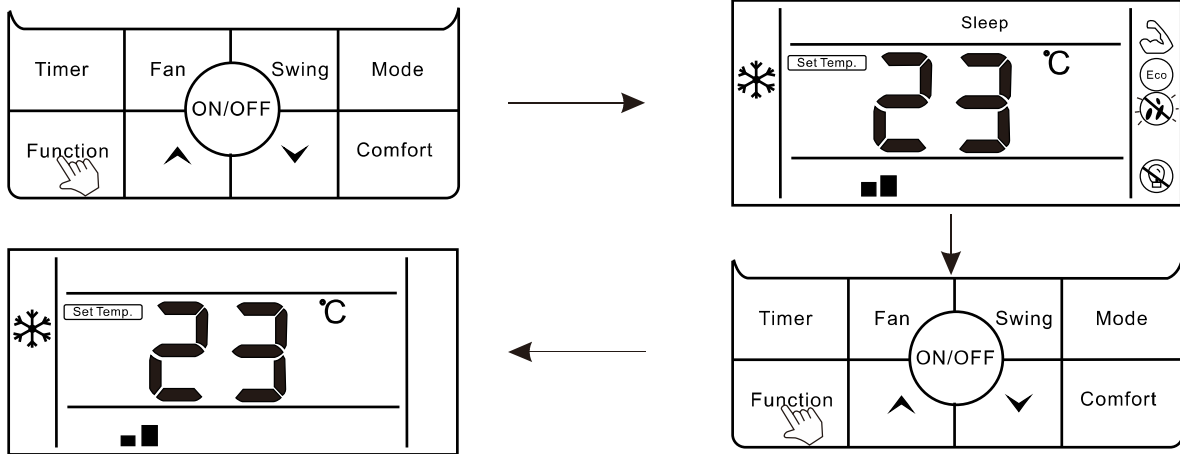

5. 【 "Light Sensation" 】

Light sensation function: Detect the On and Off of indoor lamplight and switch o low fan speed when the lamplight is off, which can reduce the noise and create a comfortable sleep environment for users

Enter light sensation function:

1. In the state of running, press "Function" button to enter the interface of function selection.
2. Press "▲" or "▼" button to light sensation function icon "💡" is flashing;
3. Press Function button again to enter light sensation function, at this moment, icon "💡" is lighting.
4. When light sensation function is on, if the indoor lamplight is OFF and lasts for 20minutes, the unit will automatically enter sleep mode. If the indoor lamplight is ON, and lasts for 20 minutes, the unit will cancel sleep mode and run according to the setting fan speed.

XK-05

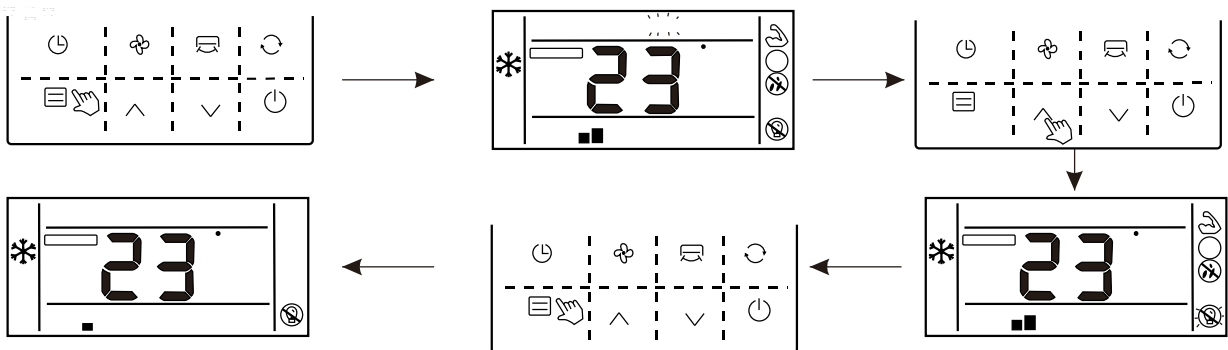

XK-04

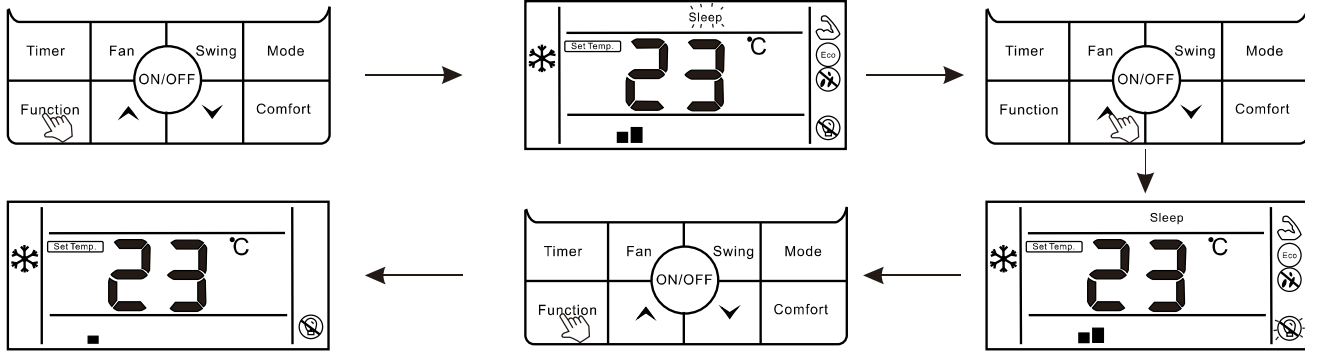

Cancel light sensation :

1. When light sensation function is on, press "Function" button to enter the interface of function selection.
2. Press "▲" or "▼" button to light sensation function icon "💡" is flashing;
3. Press Function button again to cancel light sensation function, icon "💡" will disappear

XK-05

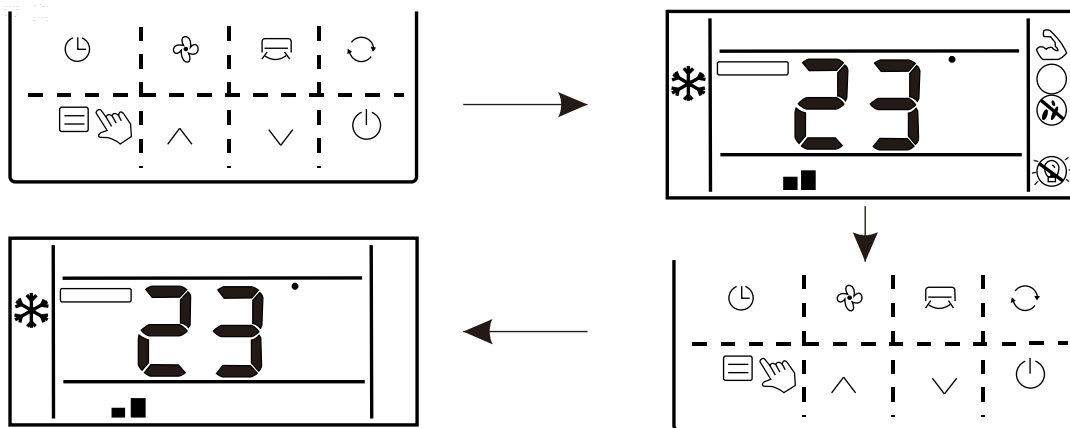

XK-04

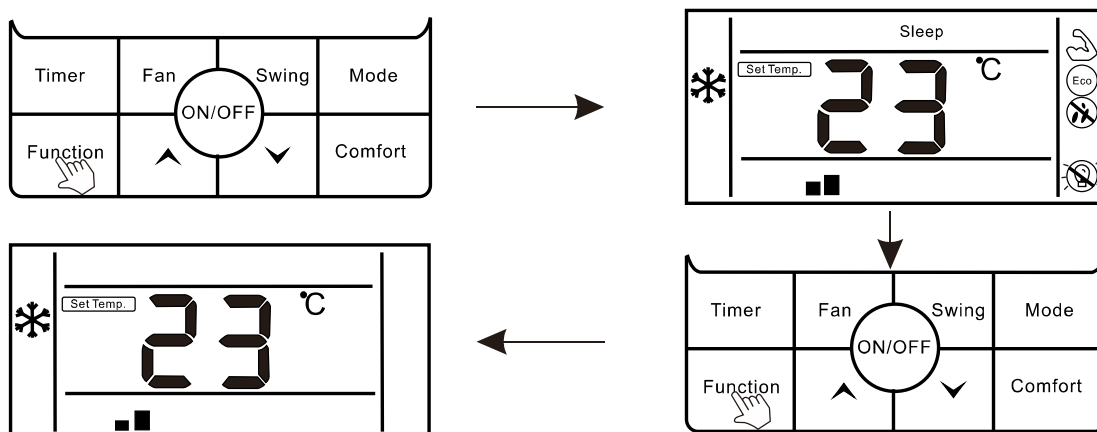

6. 【Clean】

R32 High Efficiency DC Inverter LCAC

Clean function: The air conditioner can clean the evaporator automatically, which can not only keep air fresh, but also reduce the recession of cooling effect.

Enter clean function :

1. In the state of standby, press "Function" button to enter the interface of function selection

2. Press Function button again to confirm clean function, at this moment, icon "  " is lighting

3. When the unit is performing clean function, the wire controller will keep displaying icon "  ", until it is finished

XK-05

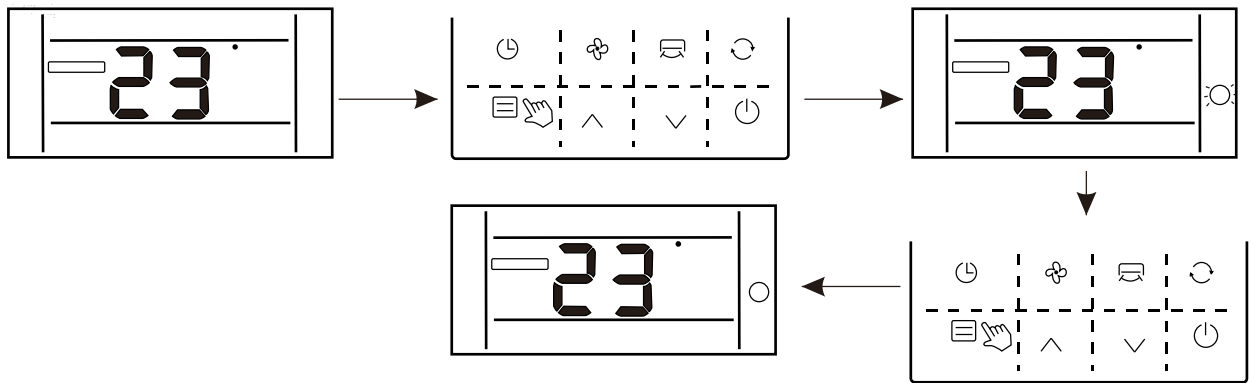

XK-04

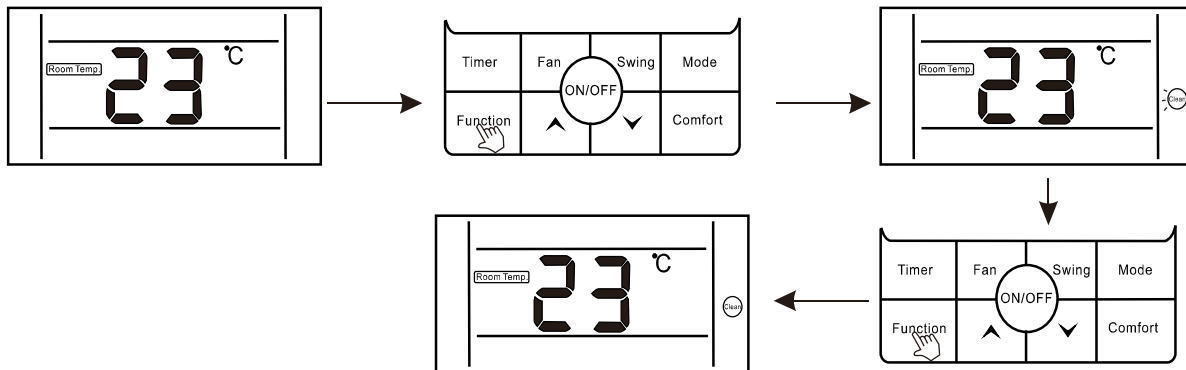

Display prompt function (10)

1. 【"WIFI"】 function display

If the unit is equipped with a WIFI function module, the icon "  " is lighting

If the unit is not equipped with a WIFI function module, the icon "  " does not display

2. 【"Shielding"】 function display

When unit is locked by centralized control, the wired controller will display

3. 【"Mute"】 function display

When the unit enter silent function, display "  " icon, when silent function is cancelled,the icon does not display.

Note: The unit without silent function can also set silent through wired controller, but it shows in the way of low wind grade, but "  " does not display.

4. 【"Oil Return / Defrost"】 function display

When the unit is running in the state of Oil Return or Defrost, "  " icon is lighting on wire controller.

When the unit has finished Oil Return or Defrost process, "  " icon does not display.

5. 【"Filter Screen Clean"】 function display

Filter screen cleaning reminder function: The unit can record its running time, when reaching the time set by the user, it will remind the user to clean the filter screen, so as to avoid prolonged cleaning and filter screen blockage, which can result in poor heating/cooling effect, abnormal protection, bacterial breeding, and other problems.

When the running time reaches the filter screen cleaning reminder time set by a user, the unit will give out a reminder of filter screen cleaning, wired controller displays"  " icon, reminding the user to clean filter screen. At this moment, long press "Timer" button for 5S to cancel the reminder, then the icon does not display. A filter screen cleaning reset signal is sent to the unit.

6. 【 Celsius and Fahrenheit switching】 display

When users set Celsius to be valid, the wired controller will display Celsius temperature.

When users set Fahrenheit to be valid, the wired controller will display corresponding Fahrenheit temperature synchronously.

7. 【 "Child Lock" function display 】

Press both " ▲ " or " ▲ " buttons for more than 5S to enter locking, the controller will display "🔒". In the state of locking, operations on the wired controller are disabled (but remote control receiving is valid).

The method of unlocking: Press both " ▲ " or " ▲ " buttons for more than 5S or power off the unit to release the locking ("🔒" does not display).

8. 【 Remote control 】 function

The wired controller can receive remote control commands and update the current status

Start-up the unit with remote controller, wired controller work in accordance with the state set on the remote controller and displays corresponding working mode;

9. Room temperature sensorequipped on the wired controller

When the wire controller is equipped with a room temperature sensor and the sensor is not damaged, it is default that the ambient temperature detected by the sensor on the controller and the temperature value will be sent to the main PCB of the unit.

If the wire controller is not equipped with a room temperature sensor or the sensor is damaged, the room temperature will be detected by the temperature sensor of the unit itself.

10.Fault display

When the unit has fault, the time bar will directly display the fault code and flash, the display mode is Er: MM (MM is the fault code, please read the corresponding roduct manual).

2. Parameters Setting

Indoor unit's parameters can be set by remote controller (YK-L) and wired remote controller—For after-sales (In indoor side ,After a new PCB was replaced, indoor parameters set is necessary).

2.1 Parameter Setting table

Parameter Serial Number	【04】	【05】	【06】	【15】
	Model of IDU	Capacity of IDU	Static Pressure setting	Selection of room sensor
ALMD-H18/NDR3HA	12	18	02	01
ALMD-H24/NDR3HA	12	24	02	01
ALMD-H30/NDR3HA	12	30	04	01
ALMD-H36/NDR3HA	12	36	04	01
ALMD-H42/NDR3HA	12	42	04	01
ALMD-H48/SDR3HA	12	48	05	01
ALMD-H60/SDR3HA	12	60	05	01
ALCA-H12/NDR3HAA(B)	37	18	03	00
ALCA-H18/NDR3HAA(B)	37	18	03	00
ALCA-H24/NDR3HAA(B)	11(01)	24	03	00
ALCA-H36/NDR3HAA(B)	11(01)	36	03	00
ALCA-H42/NDR3HAA(B)	11(01)	42	03	00
ALCA-H48/NDR3HAA(B)	11(01)	48	03	00
ALCA-H60/NDR3HAA(B)	11(01)	60	03	00
ALCF-H18/NDR3HA	13	18	03	00
ALCF-H24/NDR3HA	13	24	03	00
ALCF-H36/NDR3HA	13	36	03	00
ALCF-H42/NDR3HA	13	42	03	00
ALCF-H48/NDR3HA	13	48	03	00
ALCF-H60/NDR3HA	13	60	03	00

Note:

【04】 : Model of IDU

【05】 : Capacity of IDU ,

【15】 : Selection of air return temperature sensor; 00 – sensor in indoor unit , 01— Sensor in wired controller

2.2 Parameter Setting by YK-L

Enter the setting interface

- ① Make sure the remote controller is **off**
- ② Press the **two white button** at the down side simultaneously **more than 10s** to enter the address setting mode.

Parameter Setting

- ③ Press the [**▲**] or [**▼**] button to change the parameter series number
- ④ Press the [**IClean**] or [**ECO**] button to change the parameter correspondence
- ⑤ Press the [**MODE**] button to send order (Sent signal to display panels or receivers), Then can hearing buzzer once

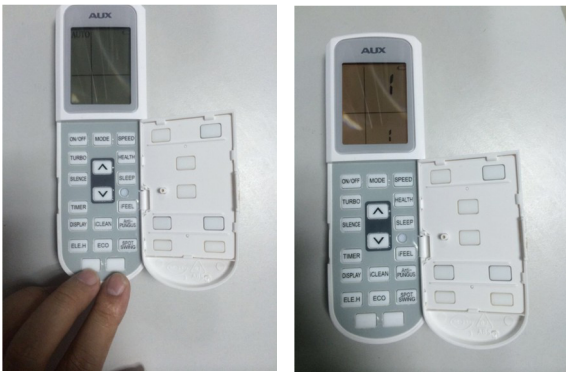
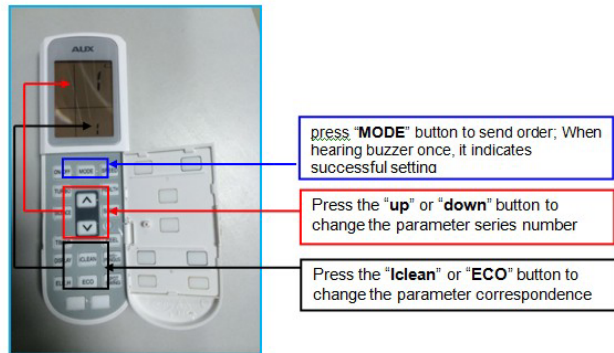

For example:

If you changed a new PCB to 18K cassette indoor unit , then you should set the type of the unit , check the above **【 Parameter Setting Items table 】** --- Mode of IDU is **【04】** , 18K cassette parameter is **【37】**

R32 High Efficiency DC Inverter LCAC



Change to

【 04 】

Change to 【 37 】 , then press 【 Mode 】 to confirm

2.3 Parameter Setting by XK-04/ XK-05

Parameter checking

Press the “FUNCTION” button for 5 seconds, enter into the parameter checking interface .

the wired controller’s address will be displayed in the temperature zone of LED screen (press “FUNCTION” button, the wired controller’s address will flash, the wired controller ‘s address can be changed through press the“^”or“v”, then press “FUNCTION” button to confirm);

In the timing setting zone :**HH** means seires NO. **MM** means parameter value. After Entering into IDU parameter checking , via pressing the“^”or“v”buton ,you can check the parameter value of seires NO. 【04】 【05】 【1】 .

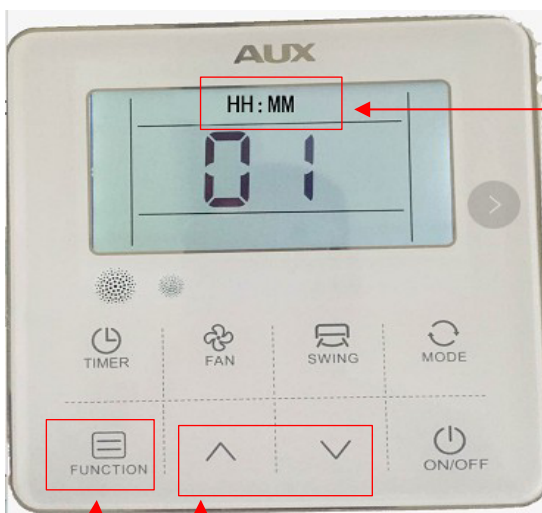

HH: means seires NO.

MM: means parameter value.

2. Press “^”or“v” , change the parameter value of seires NO.

1. Press “**FUNCTION**” for 5S , enter parmater checking model

Parameter setting

Only in parameter checking model ,press the “FUNCTION” button for 5 seconds, Enter into parameter setting model.

The corresponding parameter valve”**MM**” began to flash,changing it throuth pressing

the“^”or“v”buton,after finished ,press the “FUNCTION” button to confirm.When finishing parameter setting,it will automatically go back to parameter checking model.

R32 High Efficiency DC Inverter LCAC

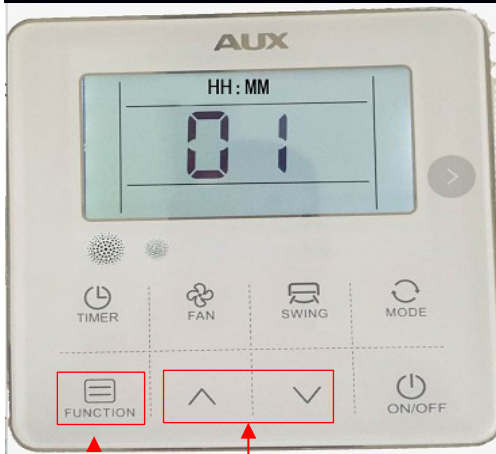

2. Press “”or“”, change the parameter value.

1. Only in checking model, Press “**FUNCTION**” for 5S ,
enter parmater checking model

For example:

If you want to change the PCB from cassette type to mid duct type for 42k unit , you should set the type of the unit , check the above **【 Parameter Setting Items table 】** --- Mode of IDU is **【04】** , 42K cassette paratmeter is **【11】** , 42K mid duct paratmeter is **【39】**

【0411】 change to **【0439】** (step1)



③ Press “**FUNCTION**” for 5S again, enter parmater setting model;

② Press the“”or“”button to get “04 11”

① Press “**FUNCTION**” for 5S,enter parmater check model;

R32 High Efficiency DC Inverter LCAC
【0411】 change to 【0439】 (step2)





④ Press the “↑” or “↓” button to get “04 39”

⑤ After finishing setting , press “FUNCTION” to confirm

3. Room Card Function

3.1 Function setting

Parameter setting	Model	Contact State	Operation model specification
0900	Normal (default)		Stand
0901	Room Card (optional)		the IDU Will be into standby mode, can be controlled by controller
			the IDU Will be into standby mode, can't be controlled by controller

※ How to set the room card function (Set method same as the above 【 Part 9 →2.2Parameter Setting by YK-L or 2.3 Parameter Setting by XK-04/XK-05 】)

For example (XK-05)

Step 1

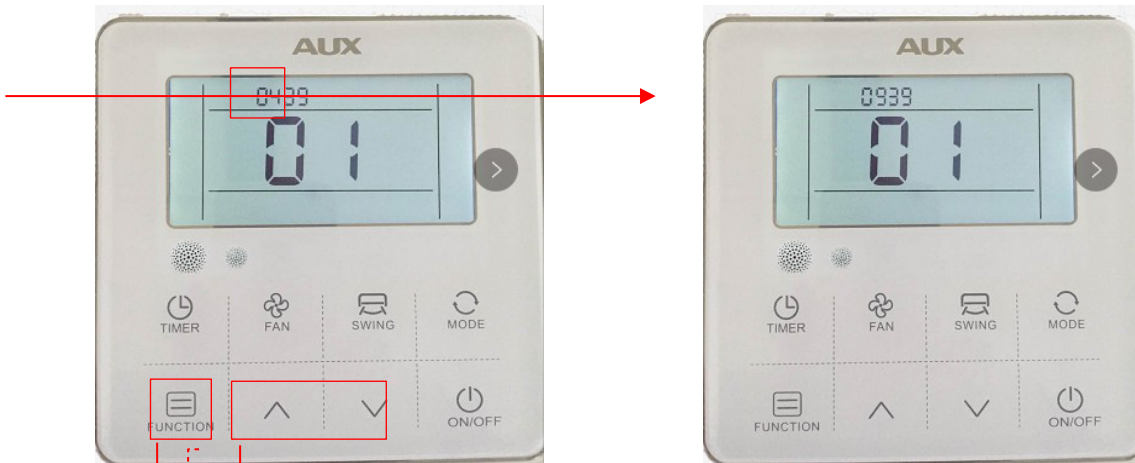

③ Press “FUNCTION” for 5S again, enter parmater setting model;

② Press the“”or“”button to get “09 39”

① Press “FUNCTION” for 5S,enter parmater check model;

Step 2

R32 High Efficiency DC Inverter LCAC



④ Press the “↑” or “↓” button to get “09 01”

⑤ after finishing setting , press “FUNCTION” to confirm

3.2 Wiring diagram

When the room card is inserted, the air conditioning can be controlled ; when you leave the room, the AC will standby, can not be controlled .

【DUCT TYPE】

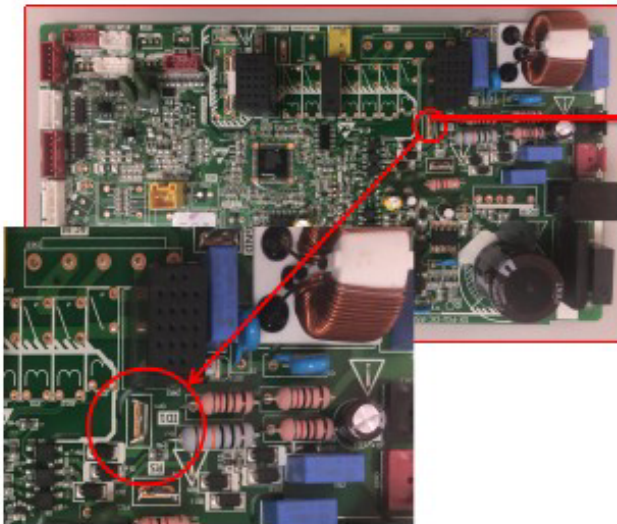

R32 High Efficiency DC Inverter LCAC
【Cassette】 and 【ceiling&floor】

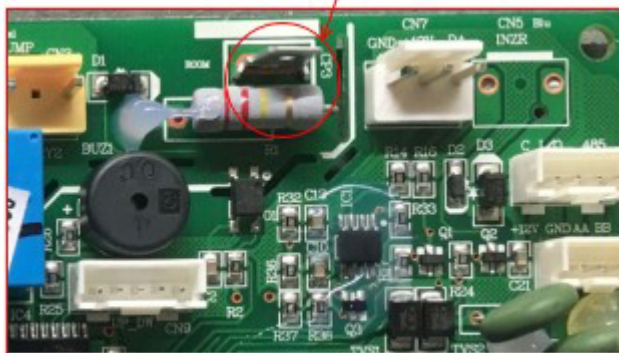
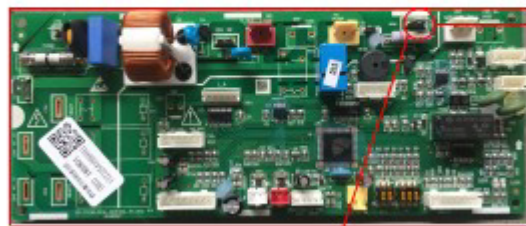

Room Card

4. Wifi Module

4.1 WiFi Module Configuration

1 APP Download

Mobile terminal scan the following dimensional code to download APP, or search “AC Freedom” in APPSTORE and Google store



2 Light Commercial WIFI Module Installation

Connect the WIFI module communication wire to WIFI interfaces of main PCB, as shown below:

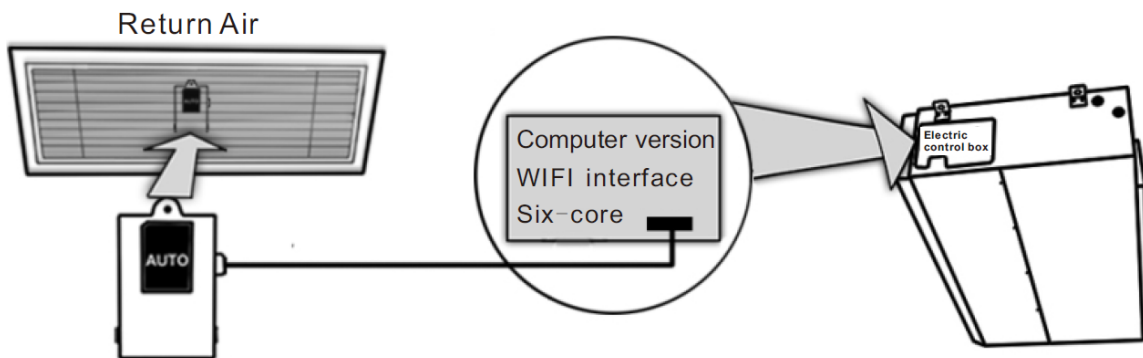

The WIFI module should be placed in the return air or some other place in WIFI area. (customers buy the wireless router)

3 APP Configuration

- Press "healthy" button 8 times consecutive, and buzzer even ring two sound then into the configuration
- Connect mobile terminals to WIFI, open APP “AC Freedom”, and then operate following the steps below:

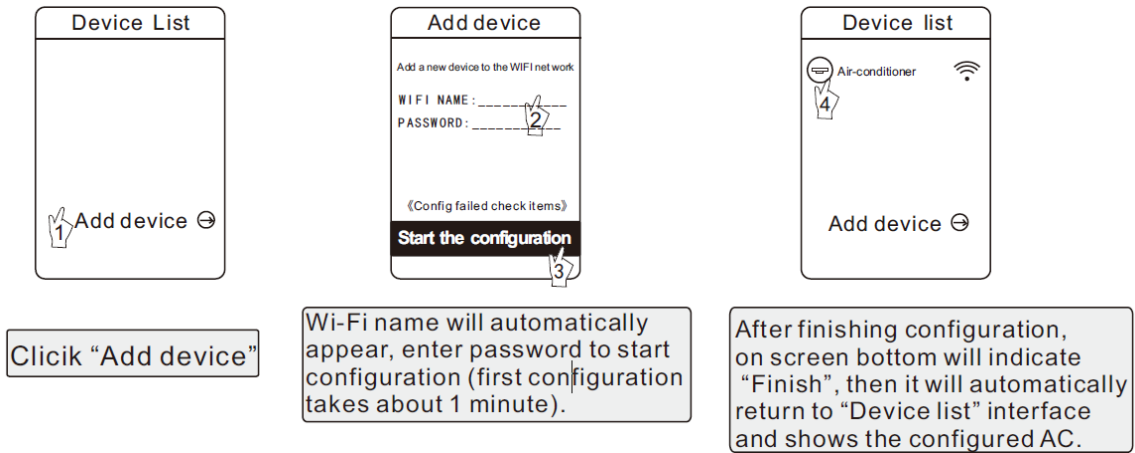

Note: If the configuration fails or you change the password of wireless router, you need to reset the WIFI module to reconnect: Turn on the power of the module, then repeat the steps above for APP configuration.

4.2 AC management

1 Modify AC name and locking function

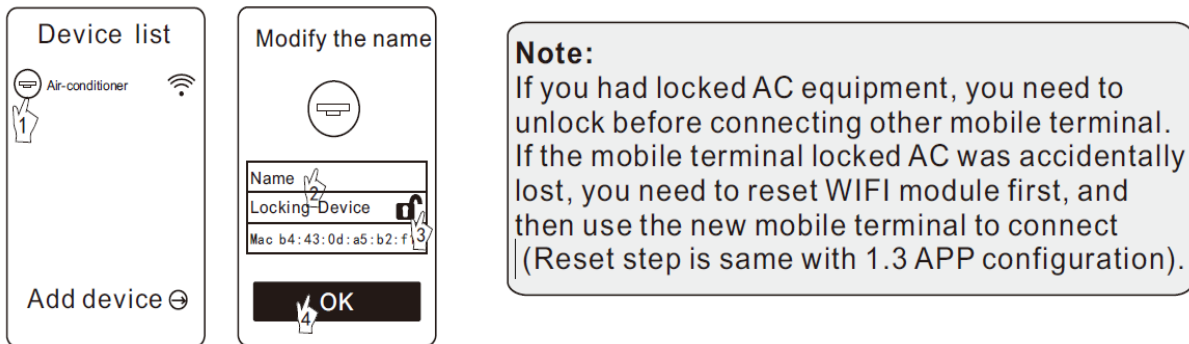

2 For other instructions, please refer to "HELP" in APP.

3 Remote-control device

Connect the wireless router to internet, then open the GPRS. It means the remote control device, voice control function only effective after connected to the Internet

4.3 Trouble Shooting

If unable to properly configured or connect the WIFI box:

- Make sure the WIFI box for wiring is properly connected.
- Long press WIFI box 8 seconds to reconfigure the positive button. If the problem can't be solved, please contact after sales person.

4.4 Technical Parameters

- Working temperature : 0~50°C ;

R32 High Efficiency DC Inverter LCAC

- Working environment humidity : 20~90%RH ;
- Dimensions : 78 X 52 X 15.5
- Configuration cable wire length : 1500mm

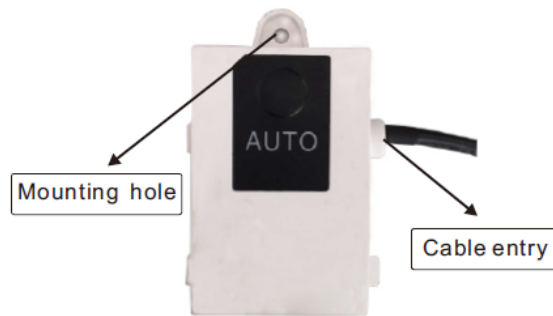

5. Static Pressure setting

5.1 Factory default

Capacity	Model	Default (Pa)	Parameters
18k/Btu	ALMD-H18/NDR3HA	20	0602
24k/Btu	ALMD-H24/NDR3HA	20	0602
36k/Btu	ALMD-H30/NDR3HA	40	0604
42k/Btu	ALMD-H36/NDR3HA	40	0604
48k/Btu	ALMD-H48/NDR3HA	50	0605
60k/Btu	ALMD-H60/NDR3HA	50	0605

5.2 Static Pressure setting (30Pa-example) use XK-05

【 Step 1 】 Feel free to touch a button and light up the screen, As shown in the right picture



【 Step 2 】 Press the “FUNCTION” button for 5s to enter the set interface, As shown in the following picture



R32 High Efficiency DC Inverter LCAC

【 Step 3 】 Press “△ ▽”button changing the first 2 numbers of “01XX” to “06XX”, As shown in the following picture

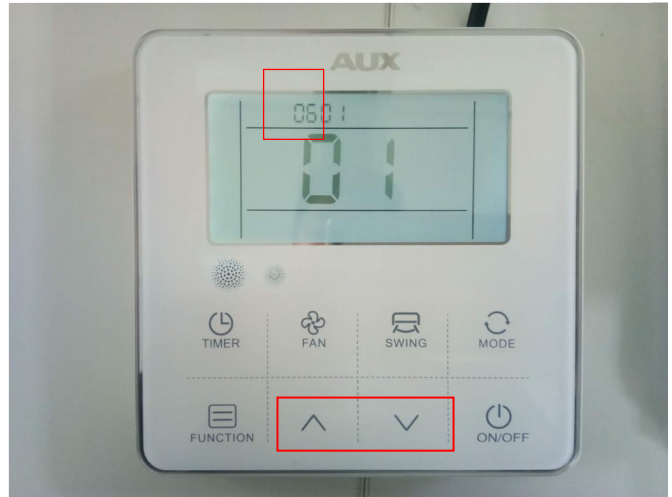

【 Step 4 】 Press the “FUNCTION” button for 5S again to enter ESP set interface, the last 2 numbers of “0601” will be Twinkle ,then Press “△ ▽”button changing the last 2 numbers of “06XX” to set the ESP of IDU,As shown in the following picture,The“0603”means that ESP of IDU is **30 Pa**.





ESP setting table

ESP(Pa)	0	10	20	30	40	50	60	70	80
parameter values	0600	0601	0602	0603	0604	0605	0606	0607	0608
ESP(Pa)	90	100	110	120	130	140	150	160	
parameter values	0609	0610	0611	0612	0613	0614	0615	0616	

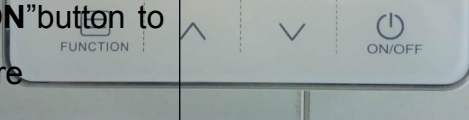
【 Step 5 】 Press “FUNCTION”button to confirm, As shown in the picture

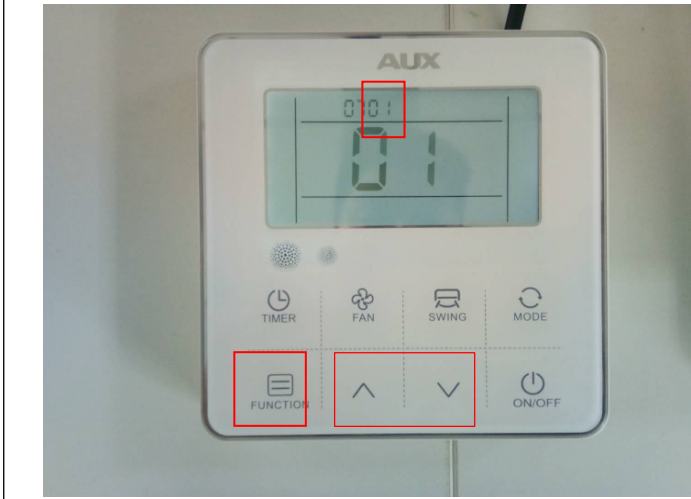

R32 High Efficiency DC Inverter LCAC

<p>【Step 6】 Press “△”button changing the first 2 numbers of “06XX” to “07XX”, As shown in the picture</p>	 A close-up photograph of the AUX remote control. The LCD display shows the number '0701'. The '07' is larger than the '01'. Below the display are several buttons: TIMER, FAN, SWING, MODE, FUNCTION, up arrow, down arrow, and ON/OFF.
<p>【Step 7】 Press the “FUNCTION” button for 5S again , the last 2 numbers of “07XX” will be Twinkle ,then Press “△▽”button change “07XX” to “0701” Confirm the ESP of IDU,As shown in the picture,</p>	 A close-up photograph of the AUX remote control. The LCD display shows '0701'. The '01' is smaller and appears to be twinkling. A red box highlights the 'FUNCTION' button and the up/down arrow buttons.
<p>【Step 8】 Press “FUNCTION”button to confirm, finishing set ,As shown in the picture.</p>	 A close-up photograph of the AUX remote control. The LCD display shows '0701'. A red box highlights the 'FUNCTION' button.

※ Use Remote controller(YK-L) and XK-04 Set method same as the above XK-05



Part10 Explosive View

1. Cassette

1.1 12K, 18K

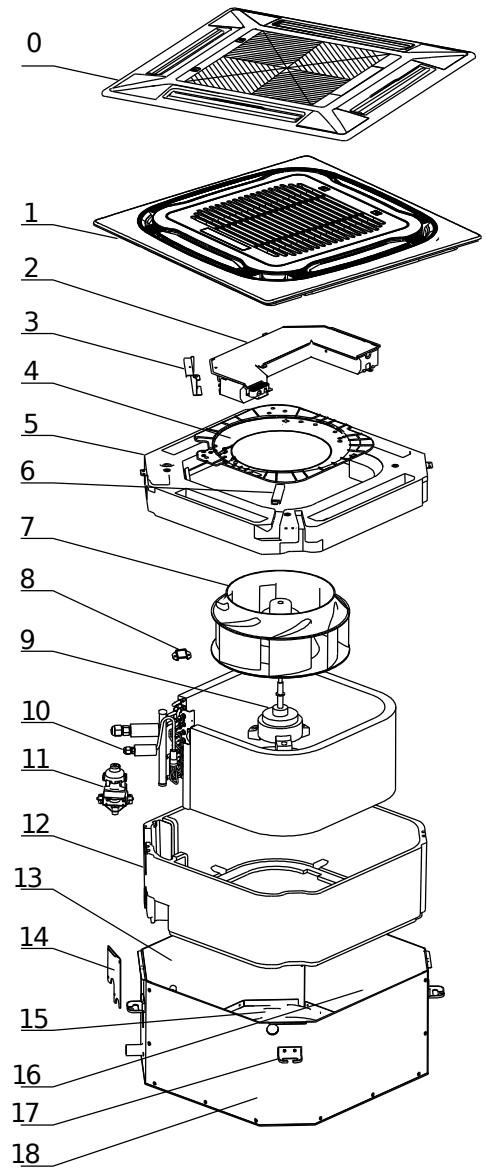
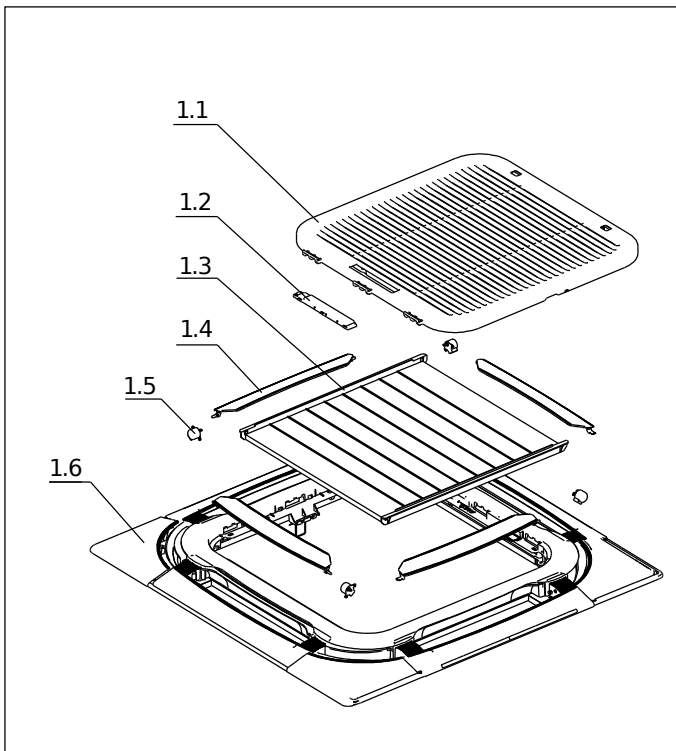
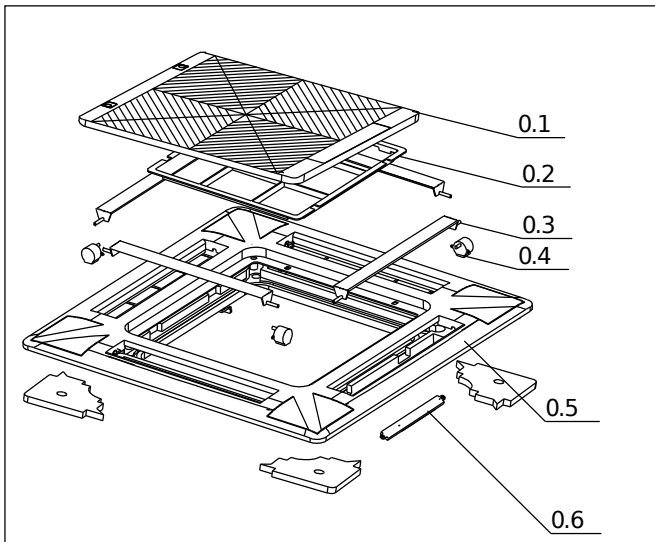

R32 High Efficiency DC Inverter LCAC

No.	Chinese Name	Part Name	Part Code	Qty
0.	面板 MB13/W-Y1	Panel MB13/W-Y1	16108022000016	1
0.1	回风格栅	Return air grille	16420010000015	1
0.2	过滤网 PP	fliter screen	16420012000012	1
0.3	导风叶片	Guide the wind vane	16420007000023	4
0.4	步进电机	Step motor	16430001000133	4
0.5	面板围框 HIPS	Panel box around	16420014000035	1
0.6	R 显示灯板组件	The led panel	16422015000007	1
1	面板 09A	Panel MB09A	16108022000017	1
1.1	回风格栅	Return air grille	16420010000033	1
1.2	R 显示灯板组件	The led panel	11222014000718	1
1.3	过滤网 PP	fliter screen	16420012000012	1
1.4	导风叶片	Guide the wind vane	16420007000035	4
1.5	步进电机	Step motor	16430001000133	4
1.6	面板围框 HIPS	Panel box around	16420013000072	1
2	电控盒组件	Electric box assembly	16321005000024	1
3	电控盒 C	Electric box C	16421038000328	1
4	导风圈	Air guide ring	16420004000008	1
5	接水盘组件	Drain pan assembly	16320005000039	1
6	过线夹	Wire clip	16420021000010	1
7	风轮	Wind wheel	16444001000037	1
8	压线扣	Wire clamp	16427018000007	1
9	直流电机	DC motor	16430001000636	1
10	蒸发器总成	Evaporator assembly	16324005000087 (12K)	1
			16324005000081 (18K)	1
11	排水泵	Drain pump	16440001000020	1
12	底盘泡沫组件	Chassis foam assembly	16320005000038	1
13	围板 B	Baffle B	16421010000072	1
14	出管口阀板	Valve plate	16434002000184	1
15	底盘组件	Chassis assembly	16321005000023	1
16	围板 C	Baffle C	16421010000073	1
17	挂耳	Hook	16421040000042	4
18	围板 A	Baffle A	16421010000071	1

R32 High Efficiency DC Inverter LCAC

1.2 24K

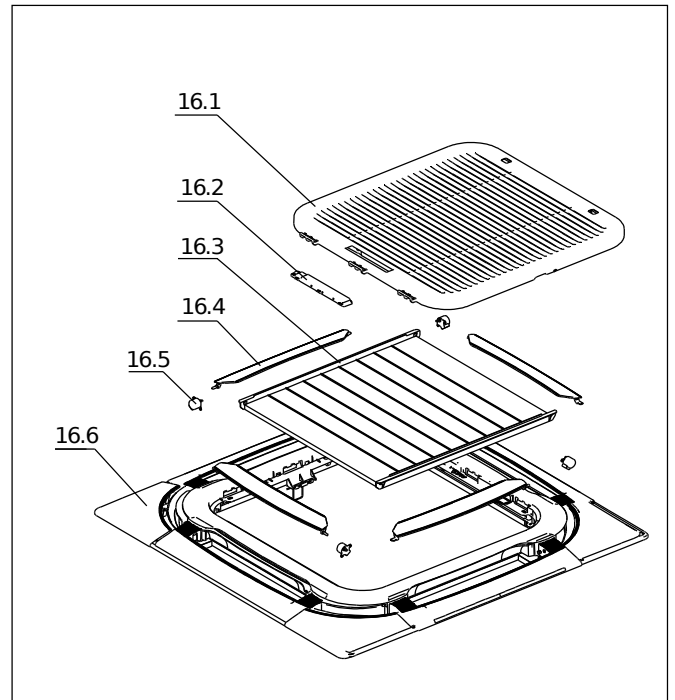
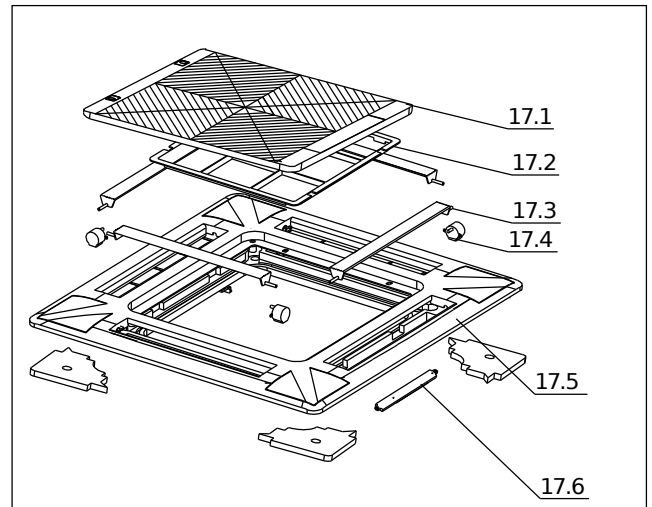
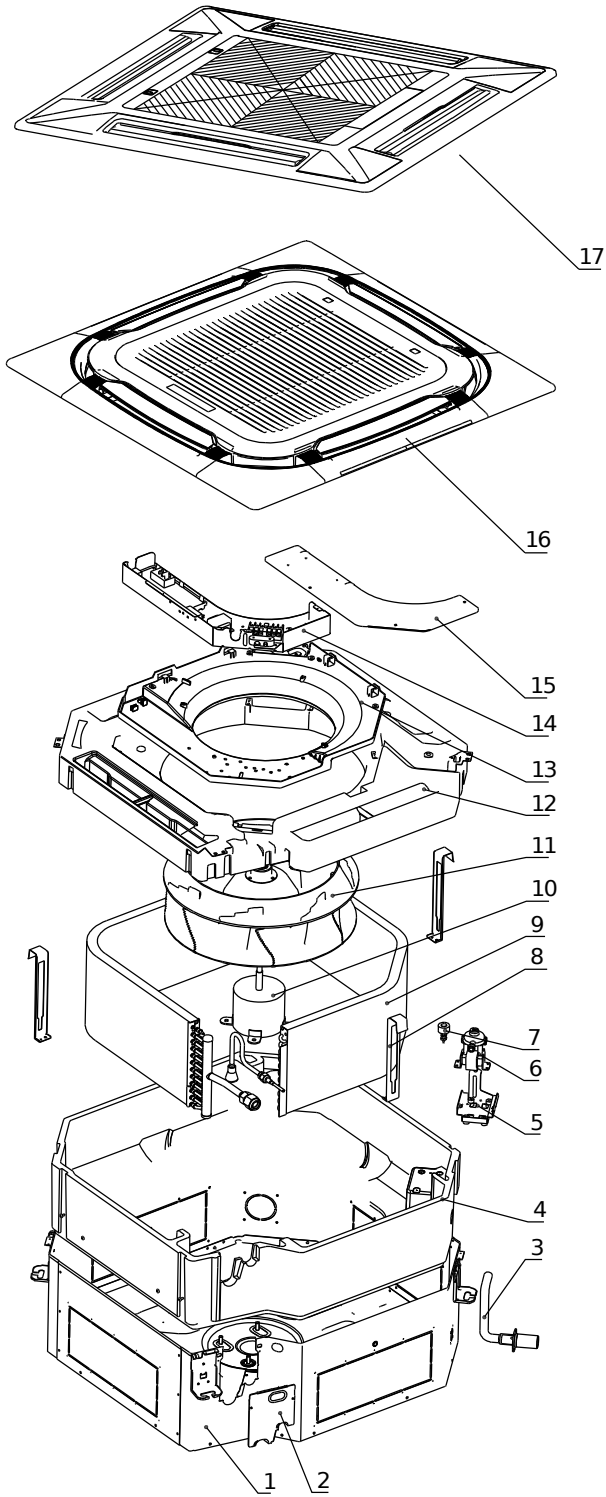

R32 High Efficiency DC Inverter LCAC

N0.	Chinese Name	Part Name	Part Code	Qty
1.	围板 A/B/C	Baffle A	16421010000034	1
		Baffle B	16421010000035	1
		Baffle C	16421010000036	1
2.	阀板	Valve plate	16420014000031	1
3.	排水管组件	Drain pipe assembly	16320005000036	1
4.	底盘泡沫组件	Chassis foam assembly	16320005000045	1
5.	水泵支架	Drain pump holder	16421026000254	1
6.	排水泵	Drain pump	16440001000016	1
7.	浮子开关	Float switch	16445034000010	1
8.	蒸发器挂钩	Evaporator hook	16421040000047	3
9.	蒸发器总成	Evaporator assembly	16324005000059	1
10.	直流电机	DC motor	16430001000508	1
11.	风轮	Wind wheel	16444001000027	1
12.	接水盘泡沫组件	Drain pan assembly	16320005000047	1
13.	导风圈	Air guide ring	16420004000007	1
14.	主控板盒	Electric box assembly	16420016000010	1
15.	电控盒盖	Electric box cover	16421038000326	1
16.	面板 08A	Panel MB08A	16108022000026	1
16.1	回风格栅	Return air grille	16420010000032	1
16.2	R 显示灯板组件	The led panel	11222014000718	1
16.3	过滤网	fliter screen	16420012000001	1
16.4	导风叶片	Guide the wind vane	16420007000034	4
16.5	步进电机	Step motor	16430001000133	4
16.6	围框	Panel box around	16420013000070	1
17.	面板 12	Panel MB12	16108002000007	1
17.1	回风格栅	Return air grille	16420010000004	1
17.2	过滤网	fliter screen	16420012000001	1
17.3	导风叶片	Guide the wind vane	16420007000009	4
17.4	步进电机	Step motor	16430001000133	4
17.5	围框	Panel box around	16420014000010	1
17.6	显示灯板组件	The led panel	11222014000704	1

1.3 36K, 42K,48K,60K

R32 High Efficiency DC Inverter LCAC

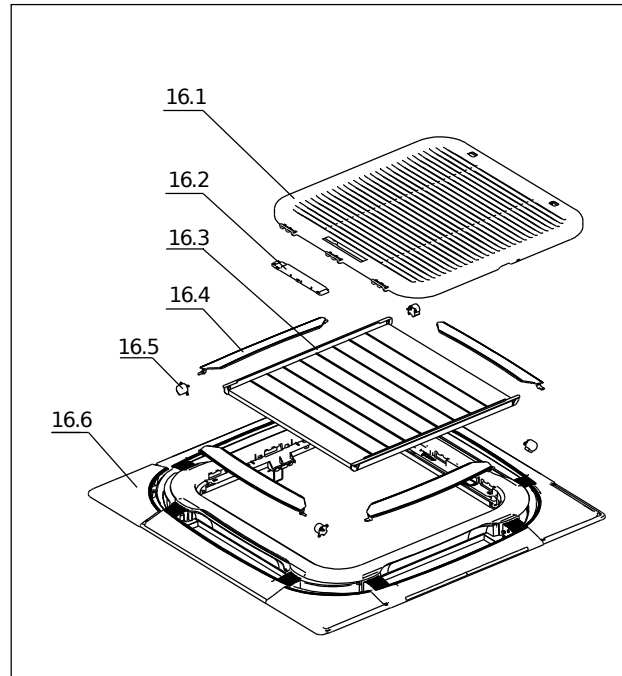
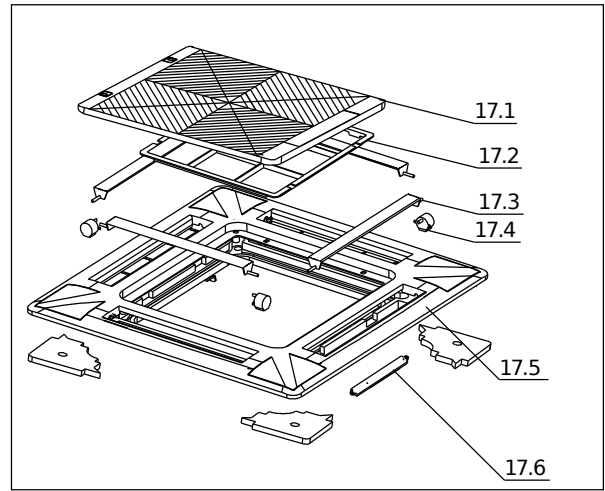
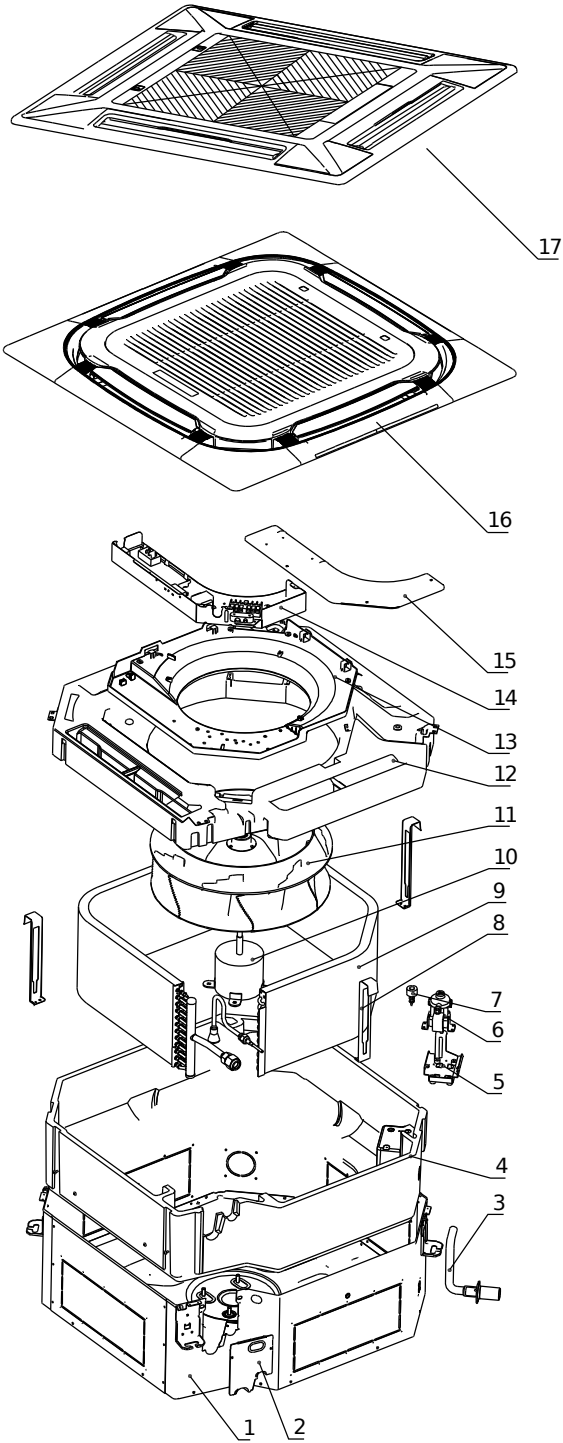

N0.	Chinese Name	Part Name	Code	Qty
1	围板 A/B/C	Baffle A	1642101000031	1

R32 High Efficiency DC Inverter LCAC

		Baffle B	16421010000032	1
		Baffle C	16421010000033	1
2	阀板	Valve plate	16420014000031	1
3	排水管组件	Drain pipe assembly	16320005000036	1
4	底盘泡沫组件	Chassis foam assembly	16320005000046	1
5	水泵支架	Drain pump holder	16421026000254	1
6	排水泵	Drain pump	16440001000016	1
7	浮子开关	Float switch	16445034000010	1
8	蒸发器挂钩	Evaporator hook	16421040000046	2
9	蒸发器总成	Evaporator assembly	16324005000067	1
10	直流电机	DC motor	16430001000617	1
11	风轮	Wind wheel	16444001000028	1
12	排水管组件	Drain pan assembly	16320005000036	1
13	导风圈	Air guide ring	16420004000007	1
14	电控盒	Electric box assembly	16421038000324	1
15	电控盒盖	Electric box cover	16421038000326	1
16	面板 08A	Panel MB08A	16108022000026	1
16.1	回风格栅	Return air grille	16420010000032	1
16.2	R 显示灯板组件	The led panel	11222014000718	1
16.3	过滤网	fliter screen	16420012000001	1
16.4	导风叶片	Guide the wind vane	16420007000034	4
16.5	步进电机	Step motor	16430001000133	4
16.6	围框	Panel box around	16420013000070	1
17	面板 12	Panel MB12	16108002000007	1
17.1	回风格栅	Return air grille	16420010000004	1
17.2	过滤网	fliter screen	16420012000001	1
17.3	导风叶片	Guide the wind vane	16420007000009	4
17.4	步进电机	Step motor	16430001000133	4
17.5	围框	Panel box around	16420014000010	1
17.6	显示灯板组件	The led panel	11222014000704	1

2. Ceiling Floor

2.1 18K

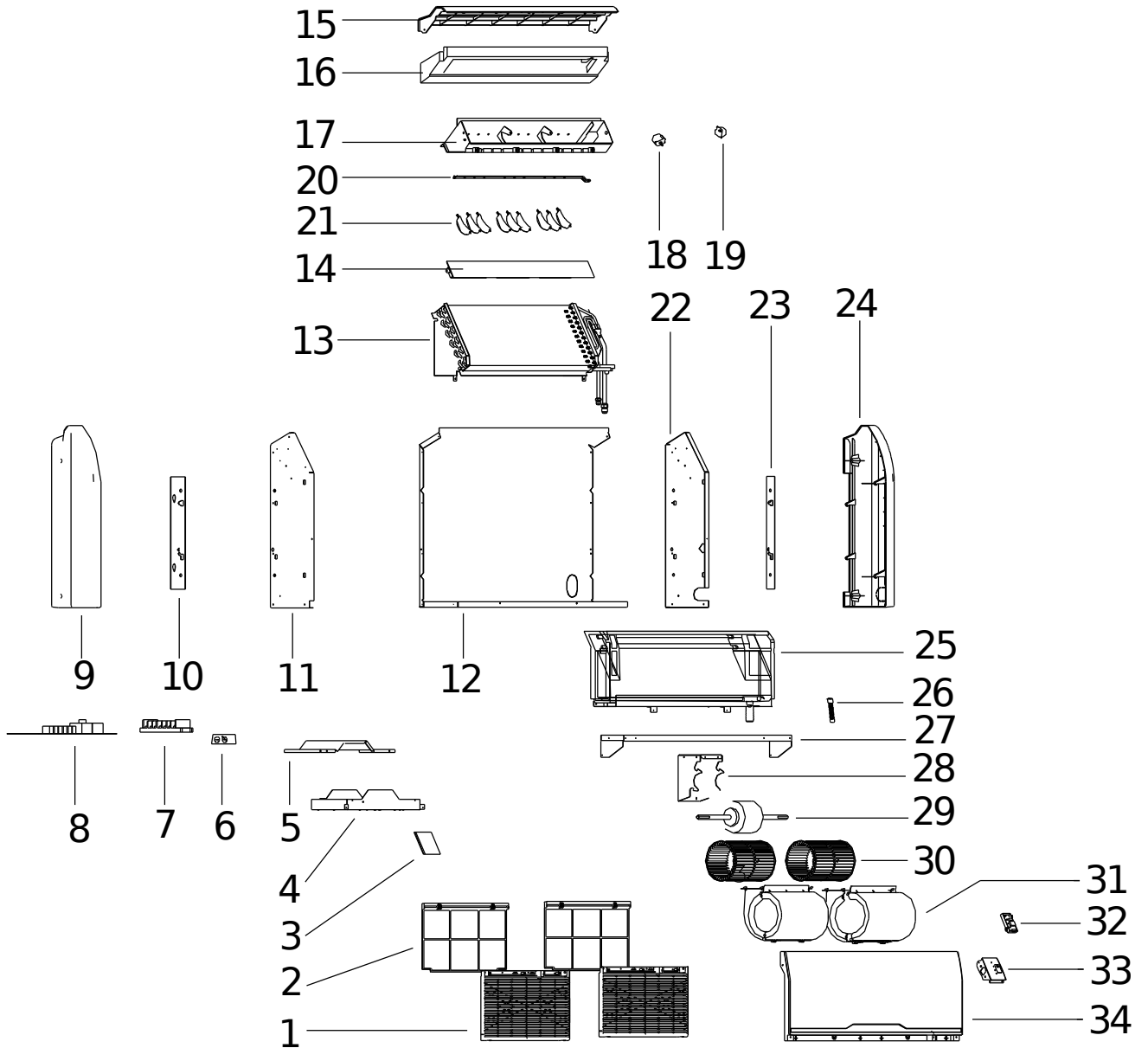

R32 High Efficiency DC Inverter LCAC

No.	Chinese Name	Part Name	Part Code	Qty
1	滤网	Air-inlet filter	16420012000002	2
2	格栅	Air-inlet grill(white)	16420010000002	2
3	左装饰板	Left side adornment plank	16420015000002	1
4	电控盒	The electricity controls box	16421038000009	1
5	电控盒盖	The electricity controls box of cover	16421005000205	1
6	双联压线座	Compress tightly electric wire seat	11220544000008	1
7	端子板 5 位	Terminal board	16427001000072	1
8	CJ 控制板	CJ Power board	11222541000042	1
	CJ 控制板	CJ Power board	11222541000041	1
9	左盖板	The left side covers	16420014000007	1
10	左挂架	Left suspend plate	16421001000029	1
11	左侧板组件	Bracket board welding assembly of left-hand	16321006000005	1
12	背板组件	Chassis welding assembly	16421018000004	1
13	蒸发器总成	Evaporator assembly	16324018000015	1
14	导风门	Sway a breeze leaf	16420005000005	1
15	顶盖板	The crest covers plank	16420014000016	1
16	顶泡沫	Topmost foam	16428001000088	1
17	导风架	Air guide louver	16420006000007	1
18	步进电机	Step motor	16430001000604	1
19	步进电机	Step motor	16430001000603	1
20	垂直叶片连杆 A	Connect a pole	16420008000003	1
21	垂直叶片	Perpendicular blade	16420007000008	9
22	右侧板组件	Bracket board welding assembly of right-hand	16321006000006	1
23	右挂架	Right suspend plate	16421001000030	1
24	右盖板	The Right side covers	16420014000008	1
25	集水盘组件	Draining tray	16421002000503	1
26	塑料排水软管	Drain pipe	16432019000021	1
27	电机固定板	Volute fixing board	16421002000190	1
28	直流电机架	Motor frame	16421035000057	1
29	直流电机	Motor	16430001000504	1
30	风轮	Centrifugal fan	16444001000013	2
31	上蜗壳	Upper spiral case	16321006000040	2

R32 High Efficiency DC Inverter LCAC

	下蜗壳	Lower spiral case	16444002000015	2
32	R 显示灯板	Display board	11222023000333	1
33	显示盒	Display board cover	16420017000002	1
34	面板	Front panel	16420013000019	

2.2 24K

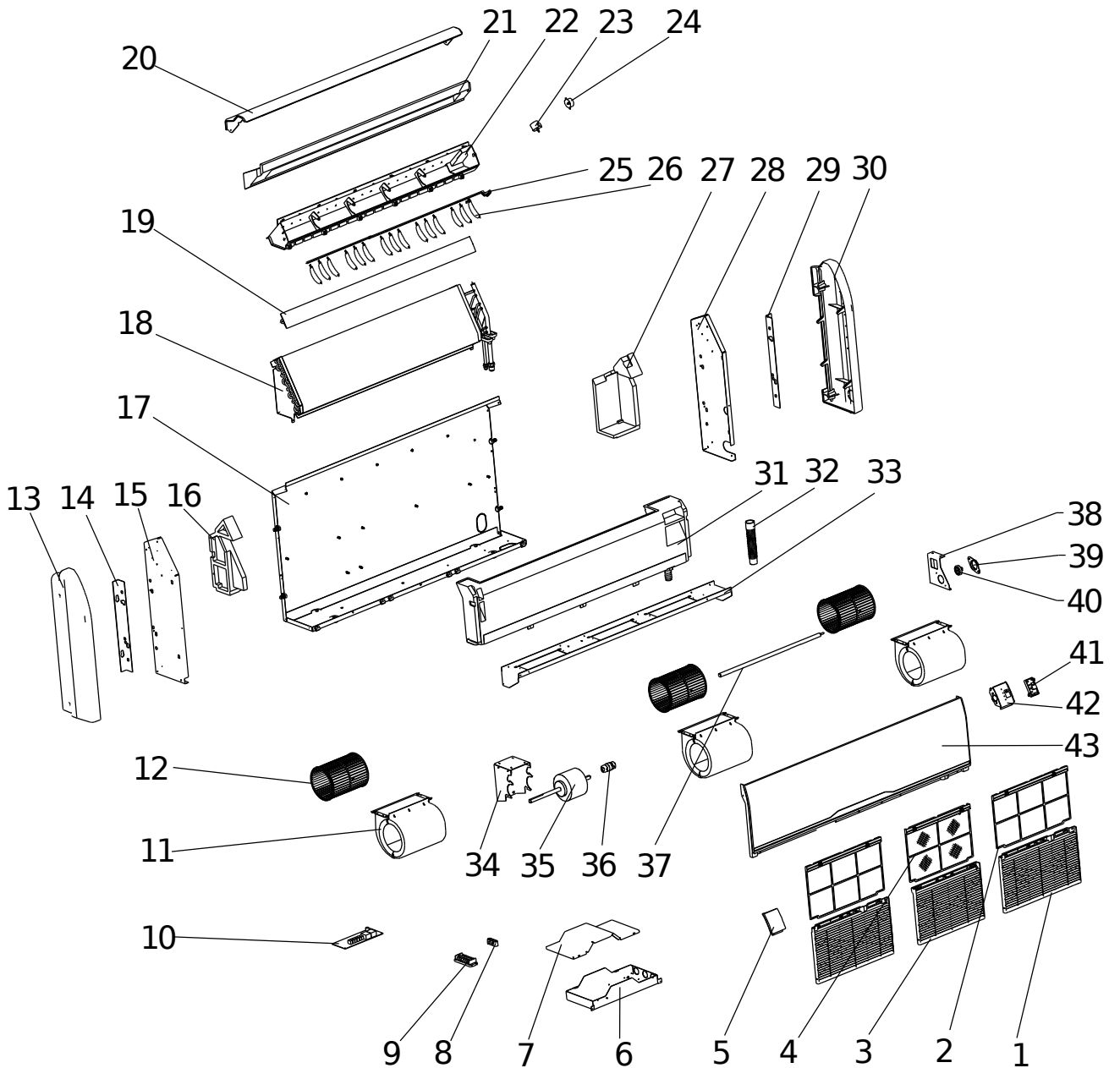

R32 High Efficiency DC Inverter LCAC

N0	Chinese name	Part Name	Part Code	Qty
1	滤网	Air-inlet filter	16420012000002	2
2	格栅	Air-inlet grill(white)	16420010000002	2
3	中滤网	In the center filter net	16420012000003	1
4	中格栅	Air-inlet grill(white)	16420010000003	1
5	左装饰板	Left side adornment plank	16420015000002	1
6	电控盒	The electricity controls a box	16421038000009	1
7	电控盒盖	The electricity controls a box of cover	16421005000205	1
8	双联压线座	Compress tightly electric wire seat	11220544000008	1
9	端子板 5 位	Terminal board	16427001000072	1
10	CJ 控制板	CJ Power board	11222541000041	1
	CJ 控制板	CJ Power board	11222541000042	1
11	上蜗壳	Top plastics	16444002000014	3
	下蜗壳	Low plastics	16444002000015	3
12	风轮	Centrifugal fan	16444001000025	1
13	左盖板	The left side covers	16420014000007	1
14	左挂架	Left suspend plate	16421001000029	1
15	左侧板组件	Bracket board welding assembly of left-hand	16321006000005	1
16	左泡沫	Left foam		1
17	背板组件	Chassis welding assembly	16321006000003	1
18	蒸发器总成	Evaporator assembly	16324018000016	1
19	导风门	Sway a breeze leaf	16420005000003	1
20	顶盖板	The crest covers plank	16420014000009	1
21	顶泡沫	Topmost foam	16428001000083	1
22	导风架	Air guide louver assembly	16420006000004	1
23	步进电机	Step motor	16430001000604	1
24	步进电机	Step motor	16430001000603	1
25	垂直叶片连杆 A	Connect a pole	16420008000003	1
	垂直叶片连杆 B	Connect a pole	16420008000004	1
26	垂直叶片	Perpendicular blade	16420007000008	15
27	右泡沫	Right foam		1
28	右侧板组件	Bracket board welding assembly of right-hand	16321006000006	1
29	右挂架	Right suspend plate	16421001000030	1
30	右盖板	The Right side covers	16420014000008	1

R32 High Efficiency DC Inverter LCAC

31	集水盘组件	Draining tray	16320006000015	1
32	塑料排水软管	Drain pipe	16432019000021	1
33	电机固定板	Volute fixing board	16421002000185	1
34	直流电机架	Motor frame	16421035000057	1
35	直流电机	Motor	16430001000506	1
36	联轴器 Φ15	Motor coupling	16444007000001	2
37	加长轴	Motor lengthen axes	16444007000028	2
38	轴承固定座 (右)	Bearing base	16421002000011	1
39	橡胶轴承压板	Bearing top cover	16421002000219	2
40	橡胶轴承	Rubber bearings	16421002000219	2
41	R 显示灯板	Display board	11222023000333	1
42	显示	Display board cover	16420017000002	1
43	面板	Front panel	16420013000016	1

R32 High Efficiency DC Inverter LCAC

2.3 36K, 42K,48K,60K

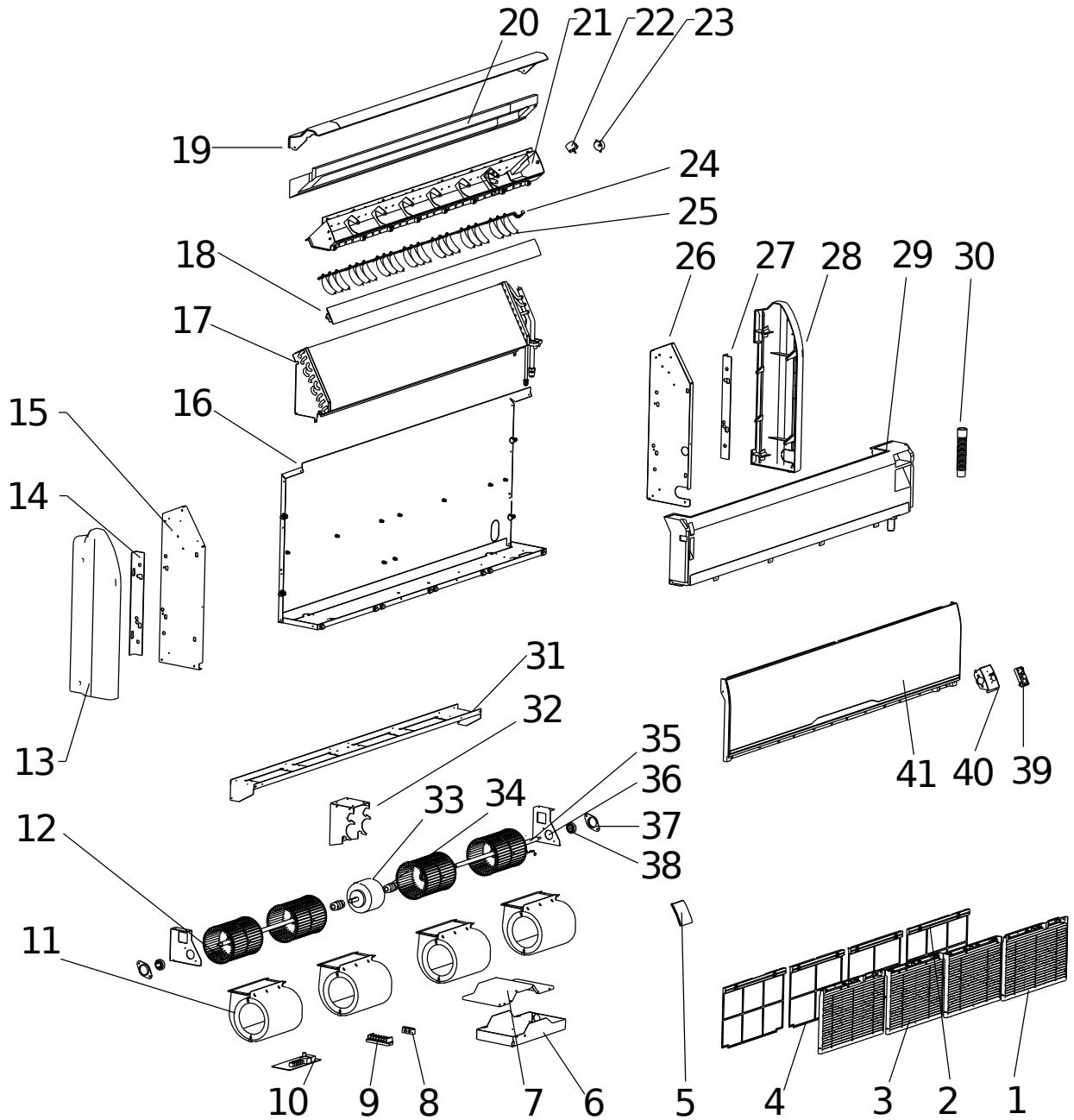

N0	Chinese name	Part Name	Part Code	Qty
1	滤网	Air-inlet filter	16420012000002	2
2	格栅	Air-inlet grill(white)	16420010000002	2
3	中滤网	In the center filter net	16420012000003	2
4	中格栅	Air-inlet grill(white)	16420010000003	2
5	左装饰板	Left side adornment plank	16420015000002	1
6	电控盒	The electricity controls a box	16421038000009	1
7	电控盒盖	The electricity controls a box of cover	16421005000205	1

R32 High Efficiency DC Inverter LCAC

8	双联压线座	Compress tightly electric wire seat	11220544000008	1
9	端子板 5 位	Terminal board	16427001000072	1
10	CJ 控制板	CJ Power board	11222541000041	
	CJ 控制板	CJ Power board	11222541000042	1
11	上蜗壳	Top plastics	16444002000014	4
	下蜗壳	Low plastics	16444002000015	4
12	风轮	Centrifugal fan	16444001000025	1
13	左盖板	The left side covers	16420014000007	1
14	左挂架	Left suspend plate	16421001000029	1
15	左侧板组件	Bracket board welding assembly of left-hand	16321006000005	1
16	背板组件	Chassis welding assembly	16421018000003	1
17	蒸发器总成	Evaporator assembly	16324006000035	1
18	导风门	Sway a breeze leaf	16420005000004	1
19	顶盖板	The crest covers plank	16420014000015	1
20	顶泡沫	Topmost foam	16428001000082	1
21	导风架	Air guide louver assembly	16420006000006	1
22	步进电机	Step motor	16430001000604	1
23	步进电机	Step motor	16430001000603	1
24	垂直叶片连杆 A	Connect a pole	16420008000003	1
	垂直叶片连杆 B	Connect a pole	16420008000005	1
25	垂直叶片	Perpendicular blade	16420007000008	21
26	右侧板组件	Bracket board welding assembly of right-hand	16321006000006	1
27	右挂架	Right suspend plate	16421001000030	1
28	右盖板	The Right side covers	16420014000008	1
29	集水盘组件	Draining tray	16320006000014	1
30	塑料排水软管	Drain pipe	16432019000021	1
31	电机固定板	Volute fixing board	16421002000187	1
32	直流电机架	Motor frame	16421035000057	1
33	直流电机	Motor	16430001000584	1
34	联轴器 Φ15	Motor coupling	16444007000001	2
35	加长轴	Motor lengthen axes	16444007000028	2
36	轴承固定座 (右)	Bearing base	16421002000011	1
37	橡胶轴承压板	Bearing top cover	16421002000219	2
38	橡胶轴承	Rubber bearings	16432016000033	2

R32 High Efficiency DC Inverter LCAC

39	R 显示灯板	Display board	11222023000333	1
40	显示盒	Display board cover	16420017000002	1
41	面板	Front panel	16420013000017	1

3. Duct

3.1 18K, 24K, 30K

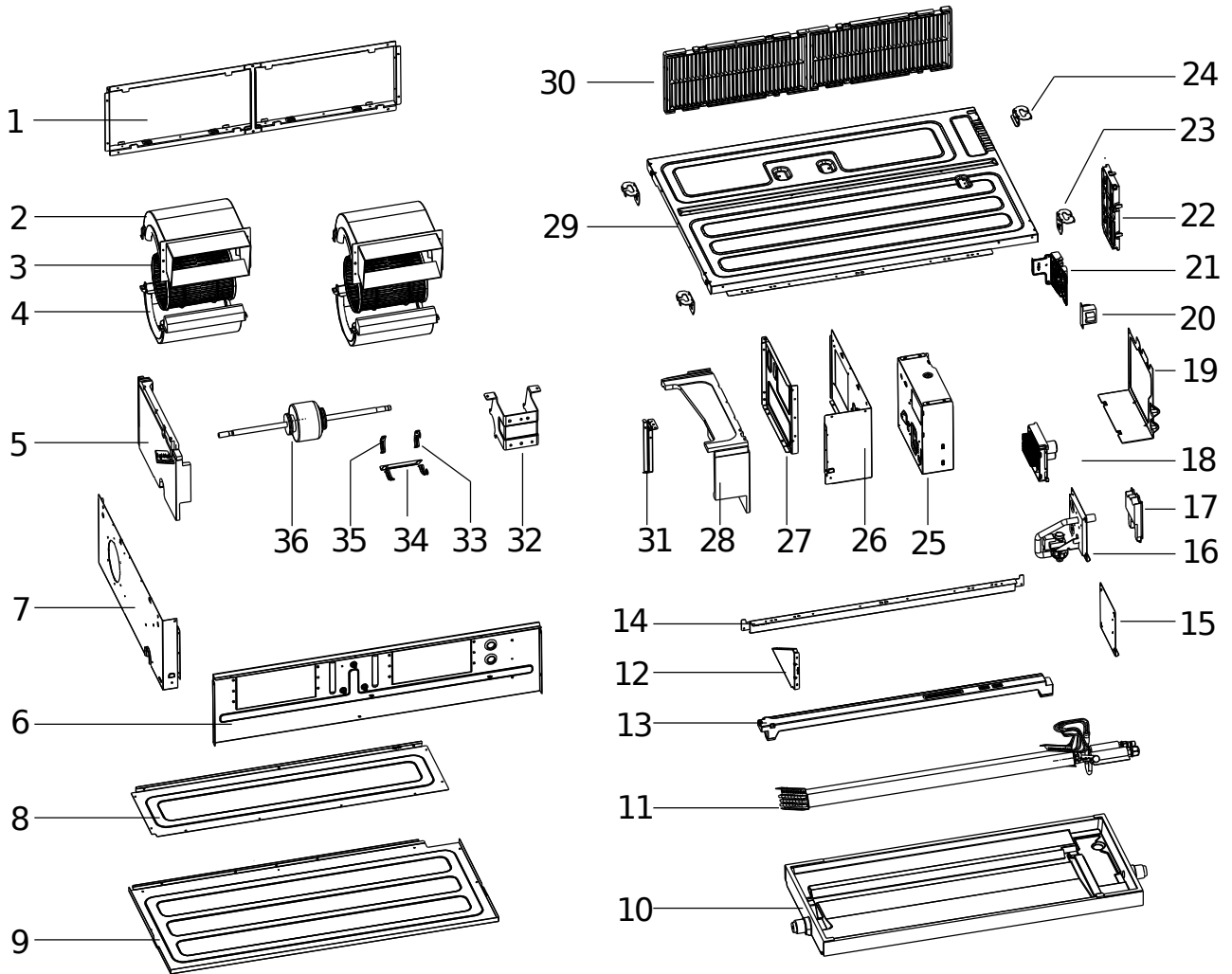

NO	Chinese Name	Part ame	Part Code	Qty
1	过滤网框架组件	filter screen	16321009000319	1
2	上蜗壳 (白色)	Top volute	16444002000024	2
3	风轮 (蓝色)	Wind wheel	16444001000039	2
4	下蜗壳 (白色)	Low volute	16444002000025	2
5	右泡沫	The right foam	16428001000085	1
6	蜗壳固定板	Volute retaining plate	16421002000498	1
7	右侧板组件	Right side panel assembly	16321009000326	1

R32 High Efficiency DC Inverter LCAC

8	后盖板	back cover	16421005000628	1
9	前盖板	front cover	16421005000626	1
10	接水盘组件	water pan assembly	16331001000156	1
11	蒸发器总成(18K)	Evaporator assembly(18K)	16324018000025	1
	蒸发器总成(24K/30K)	Evaporator assembly(24K/30K)	16324018000007	1
12	蒸发器左支撑板	Evaporator left support plate	16421003000220	1
13	中间泡沫	Middle foam	16428001000086	1
14	前法兰	Front flange	16421030000211	1
15	检修板	service panel	16421013000022	1
16	水泵组件	water pump assembly	16320009000025	1
17	风管机阀板	valve plate	16421014000117	1
18	直流风机驱动	DC Fan motor drive module	11222543000026	1
19	电控盒盖	electric control box cover	16421042000007	1
20	R电抗器	electric reactor	11330034000026	1
21	端子排固定架	Terminalboard supporting structure	16421002000497	1
22	CJ控制板	control board	11222541000049	1
23	挂耳A	Hanger A	16421040000059	3
24	挂耳B	Hanger B	16421040000060	1
25	电控盒	electric control box	16421038000359	1
26	左侧板	left side plate	16421001000769	1
27	电控盒支撑板	Electric control box support plate	16421003000217	1
28	左泡沫	Left foam	16428001000084	1
29	底盘	chassis	16421005000630	1
30	过滤网(PP)	Fliter screen	16444013000123	2
31	蒸发器下支撑板	Evaporator low support plate	16421003000219	1
32	电机架	Motor frame	16421035000078	1
33	抱攀A	Hold climbing A	16421029000062	2
34	抱攀连接板	Climbing link	16421007000171	1
35	抱攀B	Hold climbing B	16421029000063	2
36	室内直流电机	DC motor	6430034000006	1

R32 High Efficiency DC Inverter LCAC

3.2 36K, 42K, 48K, 60K

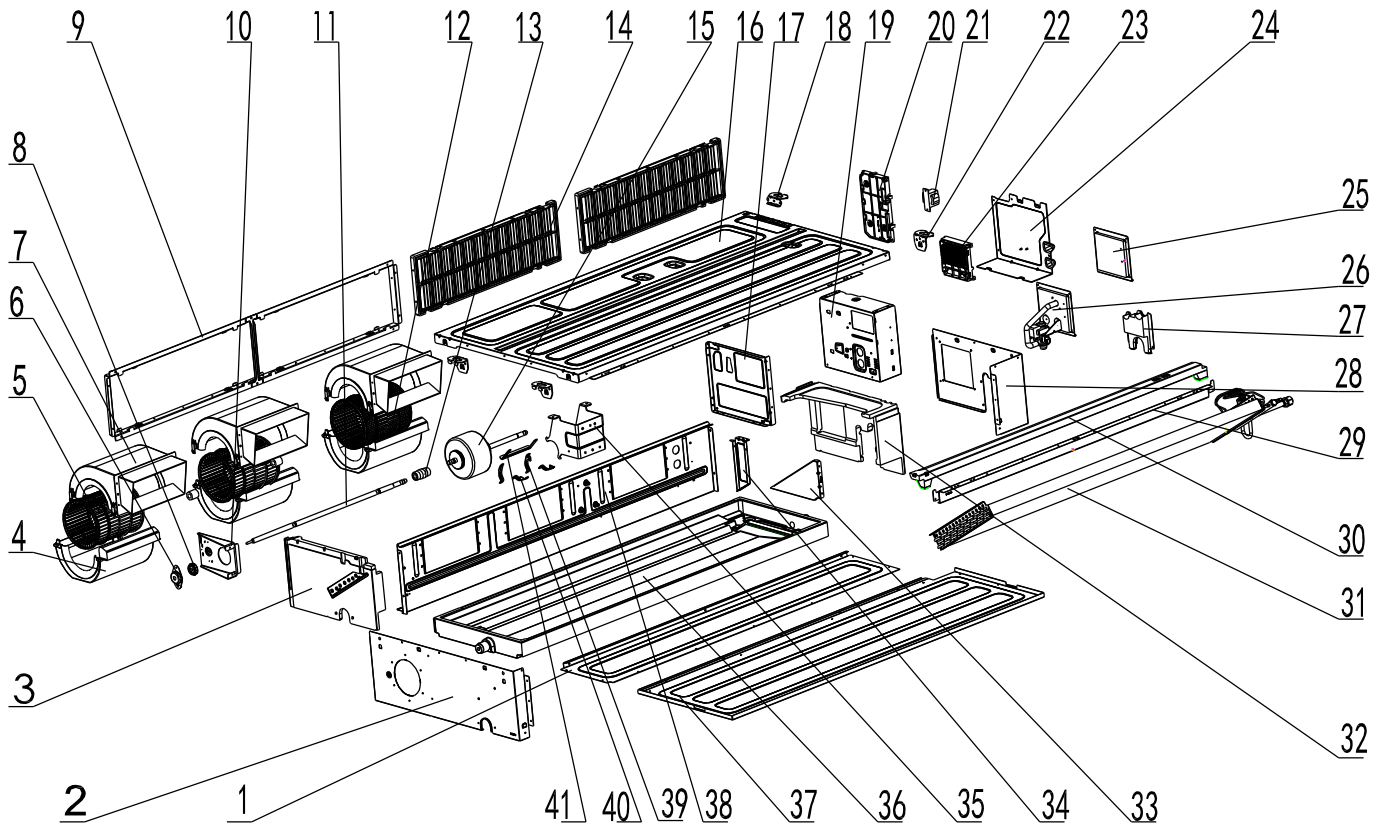

No	Chinese Name	Part Name	Part Code	Qty
1	后盖板	back cover	16421005000627	1
2	右侧板组件	Right side panel assembly	16321009000326	1
3	右泡沫	The right foam	16428001000085	1
4	下蜗壳 (白色)	Low volute	16444002000025	2
5	风轮	Wind Wheel	16444001000040	3
6	轴承压板	Bearing plate pinch	16421002000467	1
7	上蜗壳 (白色)	Top volute	16444002000024	3
8	橡胶轴承	rubber bearing	16432016000057	1
9	过滤网框架组件	Fliter Screen frame Assembly	16321009000327	1
10	轴承支架	bearing bracket	16421026000399	1
11	加长轴	extension shaft	16444007000035	1
12	风轮	Wind wheel	16444001000039	1
13	联轴器	Motor coupling	16444007000036	1
14	过滤网	filter screen	16444013000124	2

R32 High Efficiency DC Inverter LCAC

15	直流风机驱动	DC Fan motor drive module	16430034000005	1
16	风管机底盘	Chassis	16421005000629	1
17	电控盒支撑板	Electric control box support plate	16421003000217	1
18	挂耳 B	Hanger B	16421040000060	1
19	电控盒	electric control box	16421038000359	1
20	CJ 控制板	control board	11222541000049	1
21	R 电抗器	electric reactor	11330034000026	1
22	挂耳 B	Hanger B	16421040000060	3
23	直流风机驱动	DC Fan motor drive module	11222543000026	1
24	电控盒盖	electric control box cover	16421042000007	1
25	检修板	service panel	16421013000022	1
26	水泵组件	water pump assembly	16320009000025	1
27	阀板	valve plate	16421014000117	1
28	左侧板	left side plate	16421001000769	1
29	前法兰	Front flange	16421030000210	1
30	中间泡沫	Middle foam	16428001000086	1
31	蒸发器总成	Evaporator assembly	16324018000006	1
32	左泡沫	Left foam	16428001000084	1
33	蒸发器左支撑板	Evaporator left support plate	16421003000220	1
34	蒸发器下支撑板	Evaporator low support plate	16421003000219	1
35	电机架	Motor frame	16421035000079	1
36	接水盘组件	water pan assembly	16331001000155	1
37	前盖板	front cover	16421005000625	1
38	蜗壳固定板	Volute retaining plate	16421002000496	1
39	抱攀 A	Hold climbing A	16421029000062	2
40	抱攀 B	Hold climbing B	16421029000063	2
41	抱攀连接板	Climbing link	16421007000170	1

4. Outdoor Unit

4.1 12K, 18K

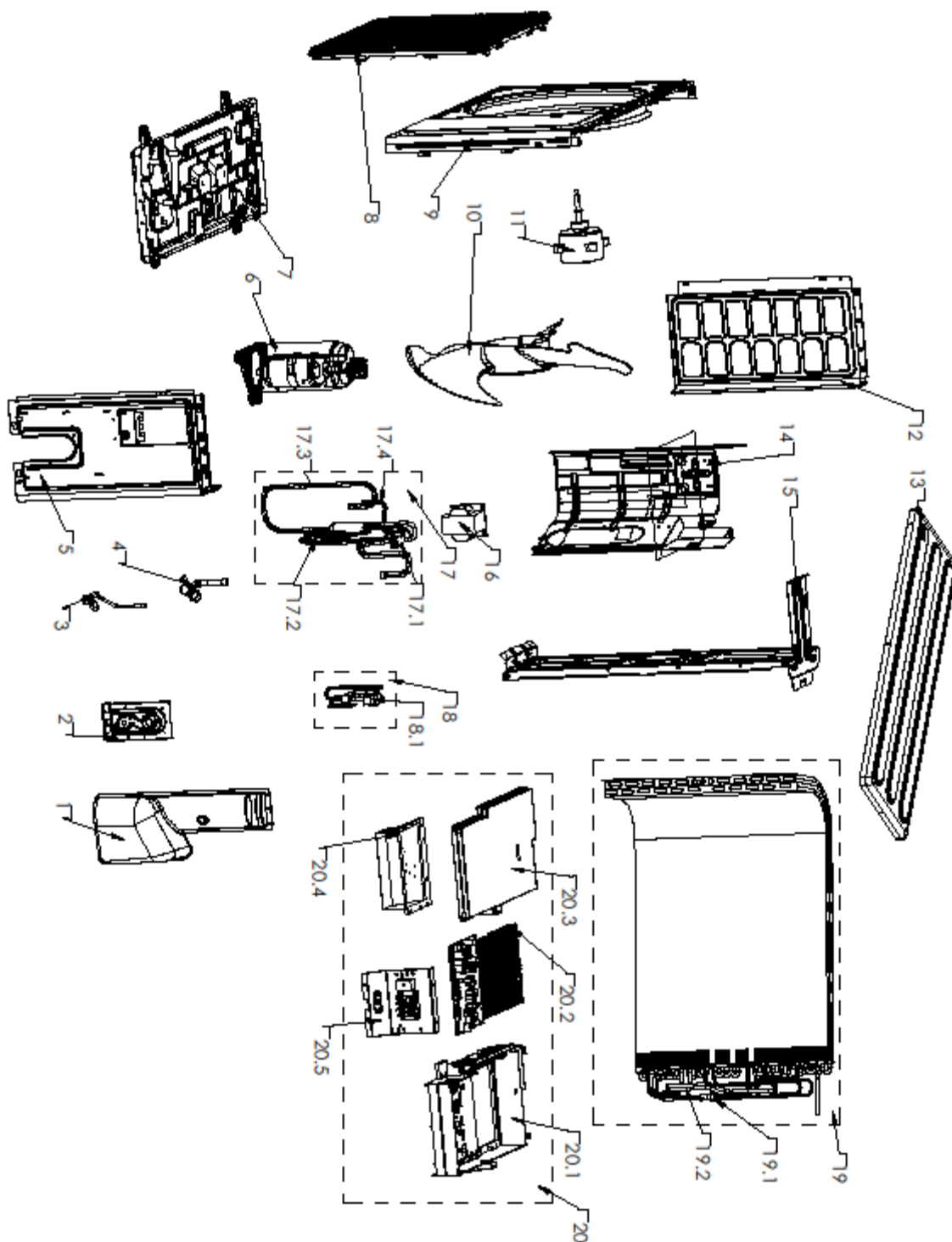

R32 High Efficiency DC Inverter LCAC

No.	Chinese Name	Part Name	Part Code	Qty
1	截止阀护套	Stop valve guard	11320101000033	1
2	阀板	Valve plate	16421014000090	1
3	截止阀	Stop valve	16441004000077	1
4	截止阀	Stop valve	16441004000046	1
5	右侧板	Right-side plate	11321007000306	1
6	压缩机及配件	Compressor and accessories	16438004000119(12K)	1
			11223003000331(18K)	1
7	底盘组件	Foundation assembly	16321004000205	1
8	网罩	Screen	11320026000061	1
9	面板	Panel	11321005000107	1
10	轴流风叶	Axial-flow fan	11320009000063	1
11	电机	Motor	11230005000012	1
12	左侧板	Left-side plate	16421001000729	1
13	顶盖板	Lamina tecti	11321009000057	1
14	隔风立板	Every wind vertical plate	11321025000051	1
15	电机架	Motor frame	11321002000040	1
16	电抗器	Electric reactor	11330034000020	1
17	四通阀组件	Four-way valve assembly	16325020000022(12K)	1
			16325020000004(18K)	1
17.1	四通阀	Four-way valve	11225509000069	1
17.2	截止阀接管	Stop valve manifold	16426018000361(12K)	1
			16426018000320(18K)	1
17.3	回气管组件	Return pipe assembly	16325004001754(12K)	1
			16426035000030(18K)	1
17.4	排气管组件	Exhaust pipe assembly	16325004001753	1
			16325004001629	1
18	膨胀阀组件	Expansion valve assembly	16325004001752	1
18.1	膨胀阀	Expansion valve	16441014000030	1
19	冷凝器总成	Condenser assy	16324004000446	1
19.1	液管组件	Fluid pipe components	16325004001314	1
19.2	进气管组件	Inlet pipe assembly	16325004001313	1
20	控制器总成	Controller assembly	11222550000018	1
20.1	电控盒	Electric control box	11320057000076	1
20.2	控制板	Control board	11222542000102	1
20.3	电控盒盖	Cover of electric control box	11321020000025	1
20.4	散热器	Radiator	11329031000036	1
20.5	控制器支架	Controller bracket	11320015000118	1

4.2 24K

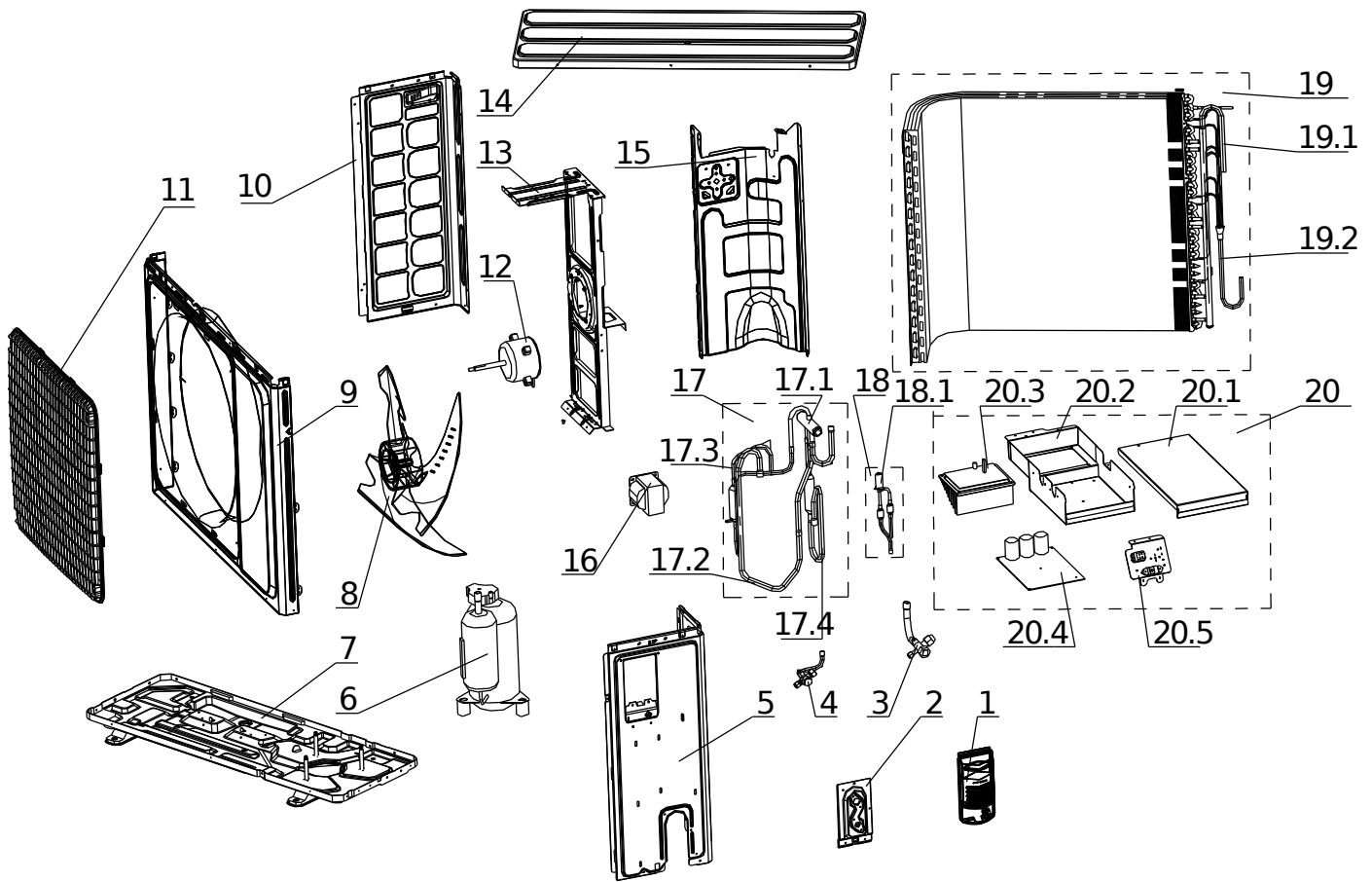

No.	Chinese Name	Part Name	Part Code	Qty
1	截止阀护套	Stop valve guard	11320101000036	1
2	阀板	Valve plate	16421014000090	1
3	截止阀	Stop valve	16441004000066	1
4	截止阀	Stop valve	16441004000080	1
5	右侧板	Right-side plate	11321007000328	1
6	压缩机及其附件	Compressor and accessories	16438003000044	1
7	底盘组件	Foundation assembly	11221502000498	1
8	轴流风叶	Axial-flow fan	11320009000065	1
9	面板	Panel	16421004000351	1
10	左侧板	Left-side plate	16421001000731	1
11	网罩	Screen	11320026000049	1
12	电机	Motor	11230005000019	1
13	电机架	Motor frame	16321004000173	1
14	顶盖板	Lamina tecti	11321009000038	1
15	隔风立板	Every wind vertical plate	11321025000055	1
16	电抗器	Electric reactor	11330034000004	1
17	四通阀组件	Four-way valve assembly	16325020000012	1

R32 High Efficiency DC Inverter LCAC

17.1	四通阀	Four-way valve	16325004001259	1
17.2	回气管组件	Return pipe assembly	16325018000009	1
17.3	排气管组件	Exhaust pipe assembly	16325004001308	1
17.4	截止阀组件	Stop valve assembly	16325004001312	1
18	膨胀阀组件	Expansion valve assembly	16325004001755	1
18.1	膨胀阀	Expansion valve	16441014000028	1
19	冷凝器总成	Condenser assy	16324004000447	1
19.1	进气管组件	Inlet pipe assembly	16325004001315	1
19.2	液管组件	Fluid pipe components	16325004001316	1
20	控制器总成	Controller assembly	11222550000019	1
20.1	电控盒盖	Cover of electric control box	11321020000025	1
20.2	电控盒	Electric control box	11320057000076	1
20.3	散热器	Radiator	11329031000056	1
20.4	控制板	Control board	11222542000103	1
20.5	电器架	Electric plane	11321015000042	1

4.3 30K

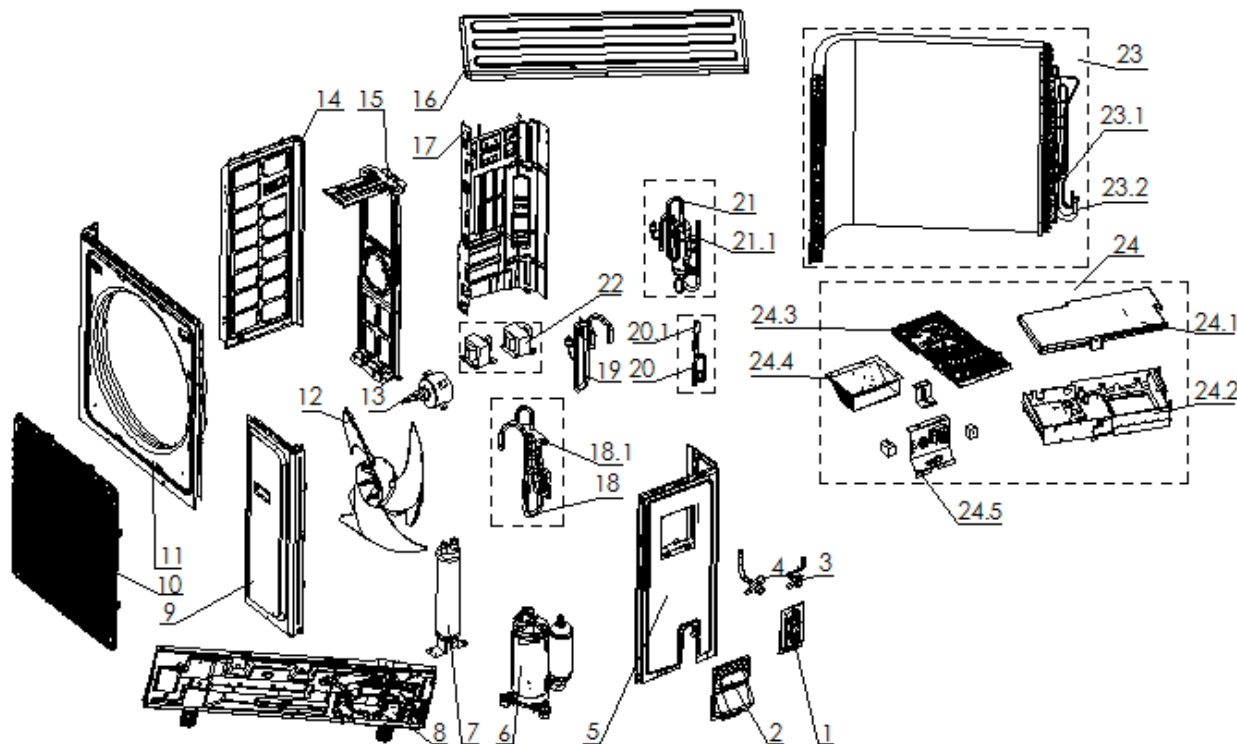

No.	Chinese Name	Part Name	Part Code	Qty
1	阀板	Valve plate	16421014000090	1
2	电器盖板	Electrical plate	11320068000006	1
3	截止阀	Stop valve	16441004000080	1
4	截止阀	Stop valve	16441004000066	1
5	右侧板	Right-side plate	11321157000027	1
6	压缩机及配件	Compressor and accessories	16438003000044	1
7	气液分离器	Liquid-vapor separator	16442023000051	1
8	底盘组件	Foundation assembly	16321018000017	1
9	小面板	The small panel	11321005000100	1
10	网罩	Screen	11320026000057	1
11	大面板	The big panel	11321005000099	1
12	轴流风叶	Axial-flow fan	11320009000061	1
13	电机	Motor	16430033000043	1
14	左侧板	Left-side plate	11321156000010	1
15	电机架	Motor frame	11321002000038	1
16	顶盖板	Lamina tecti	11321009000054	1
17	隔风立板	Every wind vertical plate	11321025000074	1
18	四通阀组件	Four-way valve assembly	16325020000021	1
18.1	四通阀	Four-way valve	11225509000064	1
19	回气管组件	Return pipe assembly	16325018000026	1
20	膨胀阀组件	Expansion valve assembly	16325034000002	1

R32 High Efficiency DC Inverter LCAC

20. 1	膨胀阀	Expansion valve	16441014000043	1
21	排气管组件	Exhaust pipe assembly	16325017000027	1
21. 1	油分离器	oil separator	16442021000020	1
22	电抗器	Electric reactor	11330034000012	2
23	冷凝器总成	Condenser assy	16324020000047	1
23. 1	出液管组件	Outlet tube assembly	16325019000038	1
23. 2	集气管组件	Gas collection tube assembly	16325004001728	1
24	控制器总成	Controller assembly	11222550000029	1
24. 1	电控盒盖	Cover of electric control box	11320058000088	1
24. 2	电控盒	Electric control box	11320057000110	1
24. 3	控制板	Control board	11222542000096	1
24. 4	散热器	Radiator	11329031000064	1
24. 5	电器架	Electric plane	11321015000074	1

4.4 36K,42K

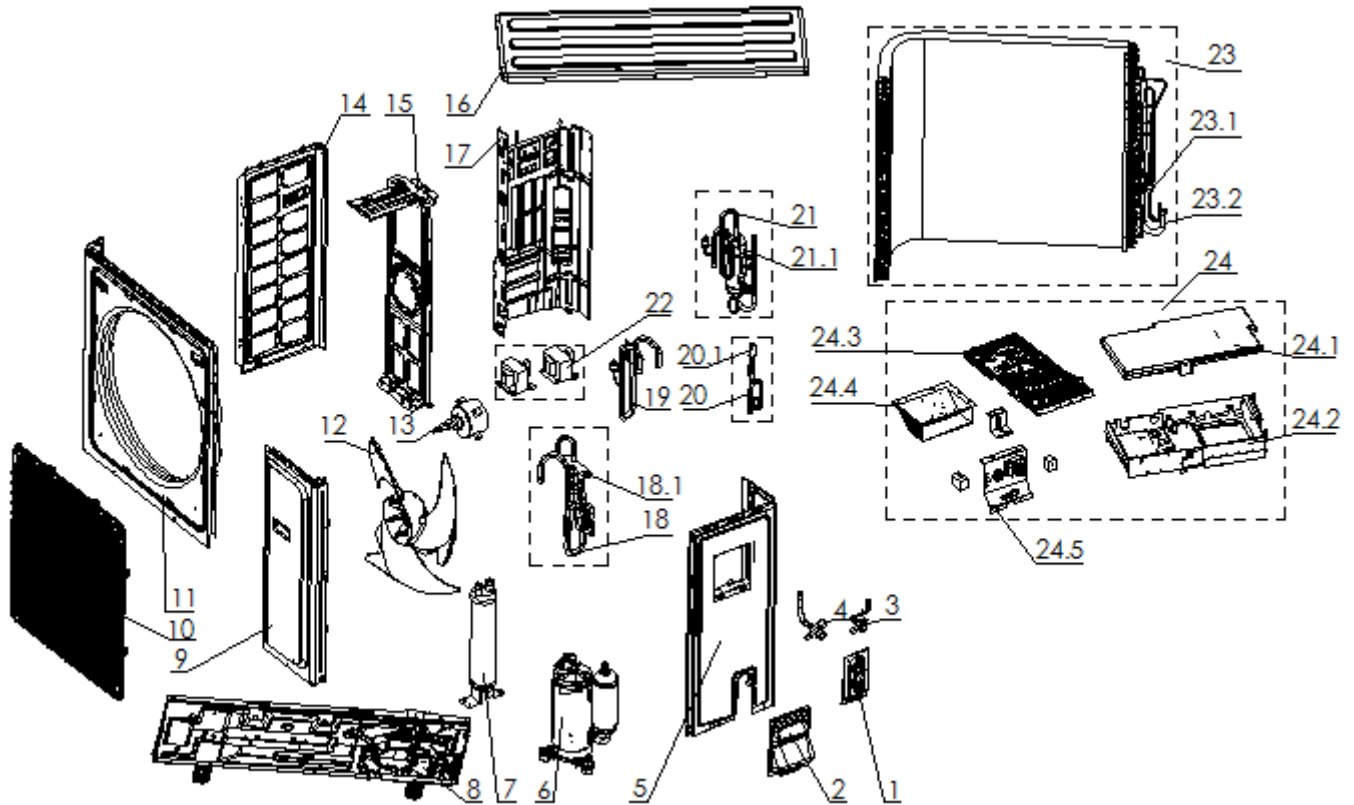

No .	Chinese Name	Part Name	Part Code	Qty
1	阀板	Valve plate	16421014000090	1
2	电器盖板	Electrical plate	11320068000006	1
3	截止阀	Stop valve	16441004000080	1
4	截止阀	Stop valve	16441004000066	1
5	右侧板	Right-side plate	11321157000027	1
6	压缩机及配件	Compressor and accessories	16438004000118	1
7	气液分离器	Liquid-vapor separator	16442023000051	1
8	底盘组件	Foundation assembly	16321018000008	1
9	小面板	The small panel	11321005000100	1
10	网罩	Screen	11320026000057	1
11	大面板	The big panel	11321005000099	1
12	轴流风叶	Axial-flow fan	11320009000061	1
13	电机	Motor	16430033000043	1
14	左侧板	Left-side plate	11321156000010	1
15	电机架	Motor frame	11321002000038	1
16	顶盖板	Lamina tecti	11321009000054	1
17	隔风立板	Every wind vertical plate	11321025000074	1

R32 High Efficiency DC Inverter LCAC

18	四通阀组件	Four-way valve assembly	16325020000021	1
18. 1	四通阀	Four-way valve	11225509000064	1
19	回气管组件	Return pipe assembly	16325018000021	1
20	膨胀阀组件	Expansion valve assembly	16325034000001	1
20. 1	膨胀阀	Expansion valve	16441014000043	1
21	排气管组件	Exhaust pipe assembly	16325017000020	1
21. 1	油分离器	oil separator	16442021000020	1
22	电抗器	Electric reactor	11330034000012	2
23	冷凝器总成	Condenser assy	16324020000044	1
23. 1	出液管组件	Outlet tube assembly	16325019000025	1
23. 2	集气管组件	Gas collection tube assembly	16325004001750	1
24	控制器总成	Controller assembly	11222550000020	1
24. 1	电控盒盖	Cover of electric control box	11320058000088	1
24. 2	电控盒	Electric control box	11320057000110	1
24. 3	控制板	Control board	11222542000096	1
24. 4	散热器	Radiator	11329031000064	1
24. 5	电器架	Electric plane	11321015000074	1

4.5 48K,60K

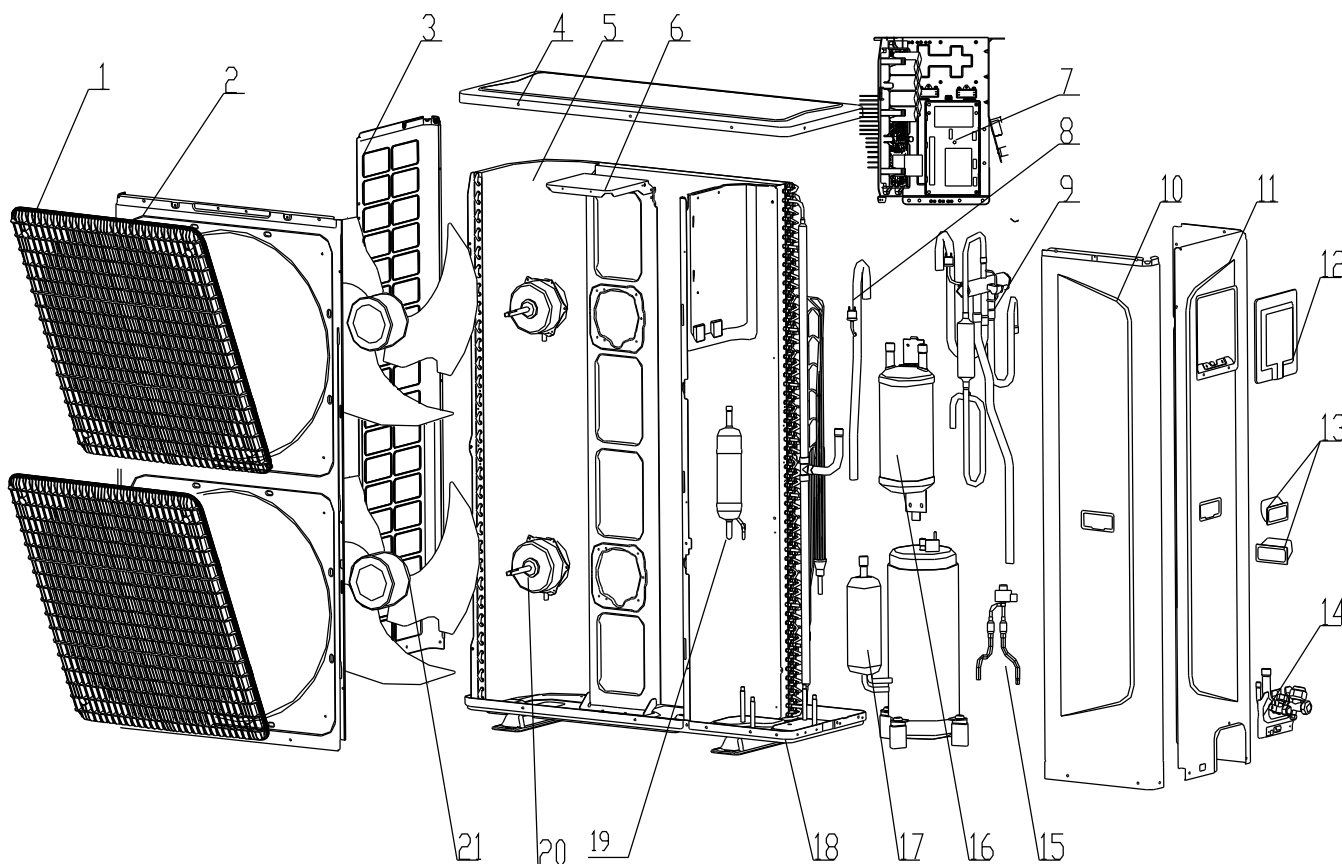

No.	Chinese Name	Part Name	BOM Code	Quantity
1	面板塑料网罩	Ventilation net cover	11320026000049	2
2	大面板	Big Board	16421004000360	1
3	左侧板	Left-side plate	16421004000362	1
4	顶盖板	Top plate	16421004000364	1
5	冷凝器总成	Condenser assembly	16324002000099	1
6	电机支架	Motor frame	16321002000175	1
7	控制器总成	Controller Assembly	11222531000009	1
8	回气管组件	muffler assembly	16325018000029	1
9	四通阀管路组件	Four-way valve assembly	16325020000034	1
10	小面板	Small plate	16421004000369	1
11	右侧板	Right-side plate	16421001000747	1
12	电器盖板	Control Box cover	11321008000003	1
13	小挖手	Dig hand	11320097000003	2

R32 High Efficiency DC Inverter LCAC

14	阀板	Valve plate	16421014000099	1
15	电子膨胀阀体	Electronic expansion valve	16441014000044	1
16	气液分离器	gas-liquid separator	16442023000048	1
17	压缩机	Compressor	16438003000047	1
18	底盘组件	chassis assembly	16321018000011	1
19	油分离器	Oil Separator	16442021000020	1
20	室外电机	Motor	16430001000583	2
21	R 轴流风叶	Axial-flow fan	11320009000065	2

Part11 Installation

1. Preparation

Please buy following spare parts from your local market before installation

Hung bolts M12, 4 pcs
Drainage pipe PVC
Copper connecting pipe
Adhesive belt (big size) 5 pcs, (small size) 5 pcs
Heat insulation material used to connect copper pipe (PE foam material, its thickness is more than 8mm)
Power cable, electrical wire between indoor and outdoor unit(Must be in accordance with the wire diameter in the wiring diagram)
Acetylene cylinders, oxygen cylinders (when longer pipe used it should be welded)
One set pipe cut machine. (cut copper pipe)
Refrigerant cans, electronic balance (when longer pipe used additional gas should be charged)
Pressure gauges, pipe clamp, welding torch, 2B silver electrode
Wrench 2 pcs, one of them is with adjustable torque wrench (42N.m,65N.m,100N.mm)
Nitrogen cylinder (in order to prevent oxidation when welding, using Nitrogen to replace the air)

2. Precaution

- ◇ Hanging location should be able to support the unit's weight, there should be no increase in noise and vibration. If the hanging location needs reinforcement, it should be reinforced before installation;
- ◇ Choose the space above the ceiling that can put the indoor unit inside;
- ◇ The location should be easy for drainage;

R32 High Efficiency DC Inverter LCAC

- ◇ The unit should not be installed in the heat source, steam or oil mist source (such as machine room, kitchen, laundry room, mechanical workshop, etc.);
- ◇ Choose the location at least 1 meter away from TV and radio, in order to avoid interference to them
- ◇ There should be certain distance between indoor unit and obstacles for maintenance;
- ◇ In case of leakage of refrigerant, units should immediately stop running, and contact with maintenance personnel in time. There must be no fire at the site, because the refrigerant will turn to harmful gas when get to the fire.

3. Cassette installation

3.1 Installation spacing

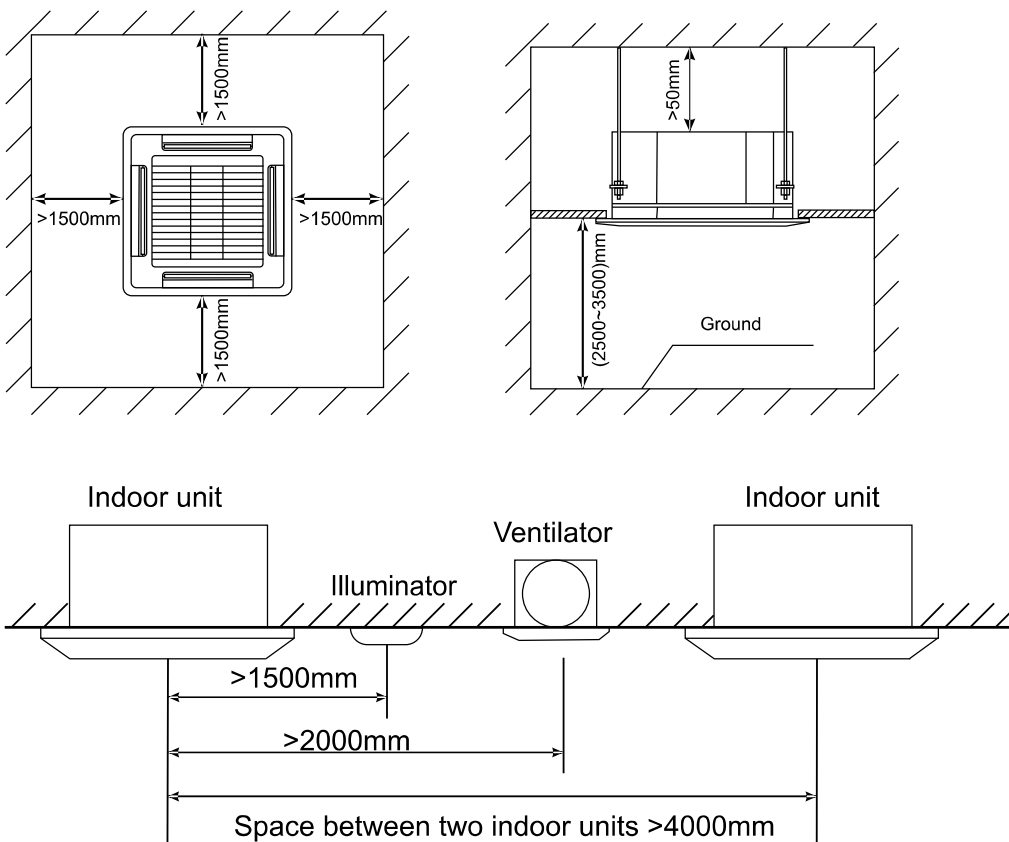

3.2 Indoor unit suspension

- ◇ Select the suspension foundation:

The suspension foundation is a structure of either wooden frame or reinforced concrete. It must be firm and reliable to bear at least 4 times weight of itself and capable of bearing vibration for long periods.

- ◇ Fixing of suspension foundation:
- ◇ Fix the suspension bolts either as shown in the picture or by a steel or wooden

R32 High Efficiency DC Inverter LCAC

bracket.

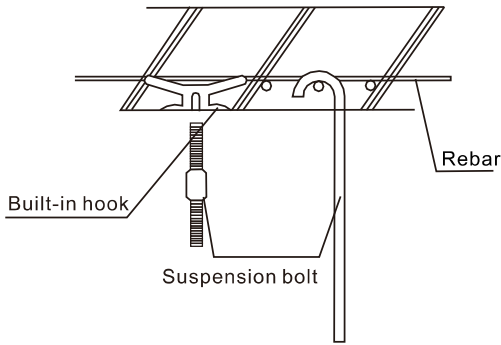

◇ If this unit is installed on a sloping ceiling, a cushion block should be installed between the ceiling and the air outlet panel, in order to ensure that the unit is installed on a level surface.

This is as shown in the drawing as follows:

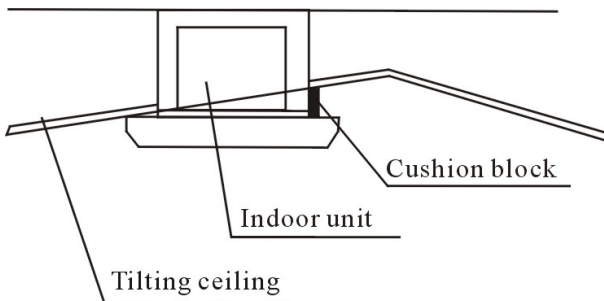

◇ Adjust the relative position of the suspension hook on the suspension bolt so that the unit can be in level position in all directions. Check with a level gauge after installation to ensure that the indoor unit is horizontal, otherwise it will cause water leakage, air leakage etc.

◇ Tighten the bolt and ensure that four hooks are in close contact with the nuts and washers, to fix the indoor unit under the ceiling.

◇ After the unit is installed ensure it is secure and does not shake or sway.

◇ Ensure that the centre of the indoor unit is in alignment with the centre of the opening in the ceiling.

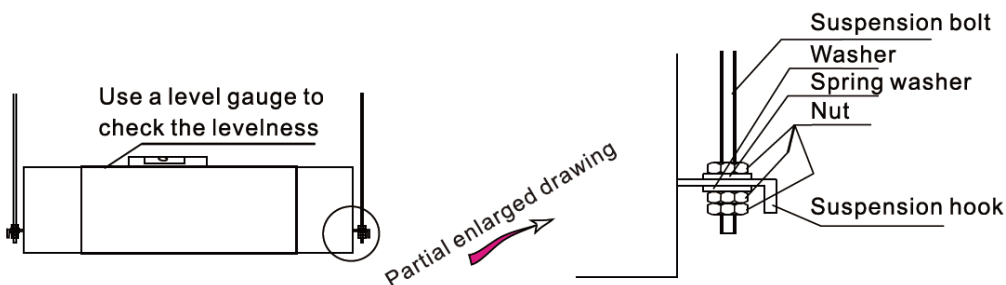

3.3 Drainage pipe

The drainage pipe should be properly insulated to prevent the generation of

R32 High Efficiency DC Inverter LCAC

condensation. Heat insulation material: the thickness of rubber insulation pipe should be more than 8mm

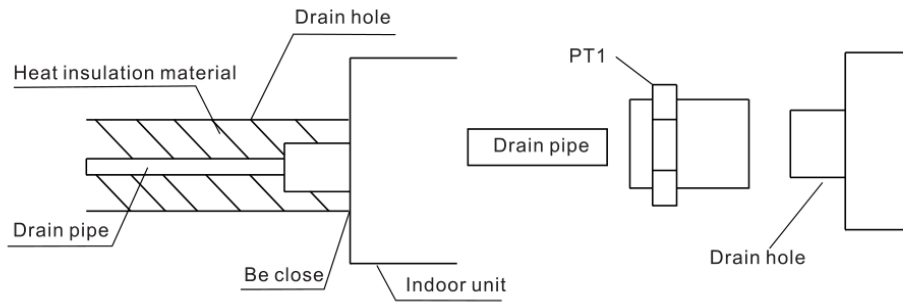

◇ Drainage pipe must have a downward gradient (1 / 50 1 / 100). To avoid water backflow or leakage etc.

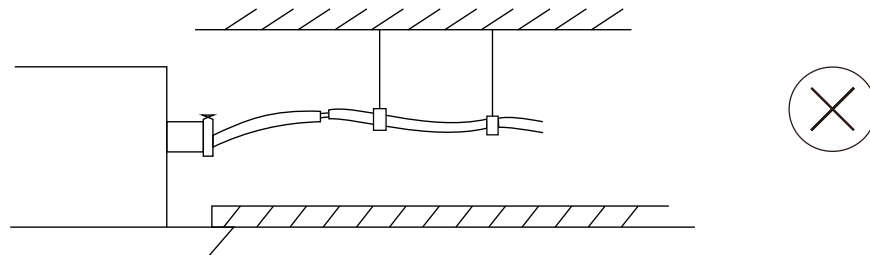
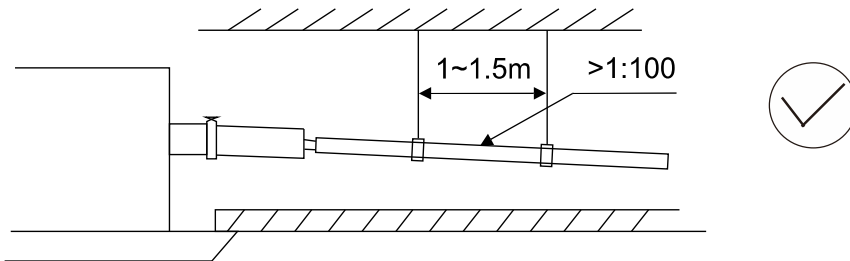

◇ The unit has a drain pump which will lift up to 1200mm. However after the pump stops the water left in the pipe will drain back and may overflow the drain tray causing water leakage. For this reason please install the drain pipe as shown

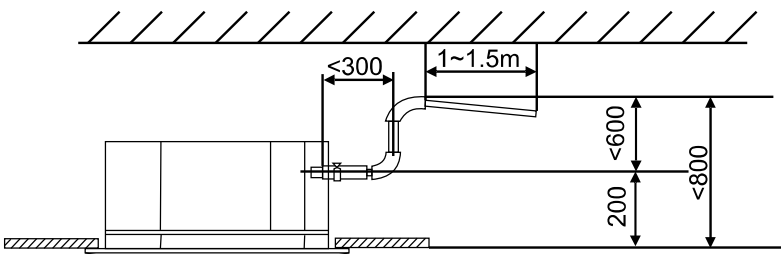

◇ When draining multiple units into a common drain line, this common drain should be installed about 100mm below each units drain outlet, as shown in the drawing.

R32 High Efficiency DC Inverter LCAC

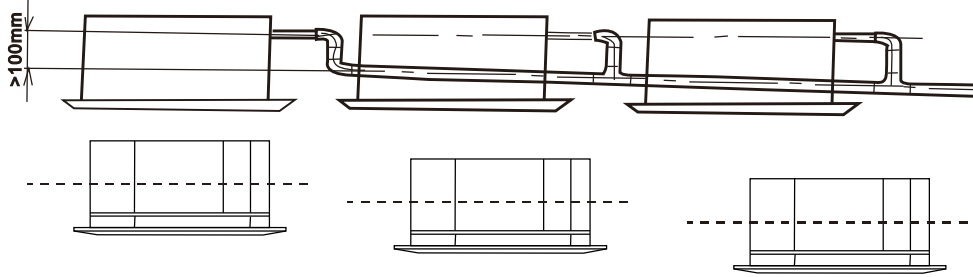

◇ When finish installation please carry out the drainage test to ensure that the water flow through the pipeline fluently, and carefully observe the junction to ensure that there is no water leakage. If the unit is installed in the newly built house, strongly recommend that this test taken before the ceiling installation. Even it is the heating only unit, this test is unavoidable.

3.4 Panel installation

Panel please refer to the following picture, the panel has four hooks which attach to corresponding hangers on the unit and the panel should be positioned using these first. The panel is then fixed into position by four bolts which are accessed through the four corner panels on the grille. The MB 13/MB09 Panel turn the four screws to the indoor unit.

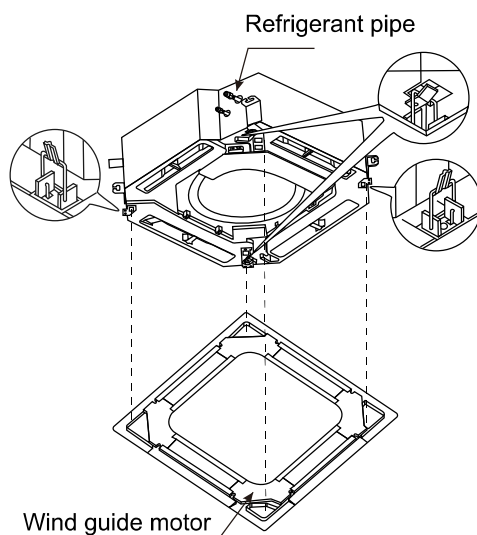

3.5 Connect, fresh air ventilation

In order to meet different customers' requirements and their different usage environment, the 24k indoor unit more than 24k reserves one fresh air ventilation hole and four duct connection holes. The fresh air can be introduced from outside or through

duct.

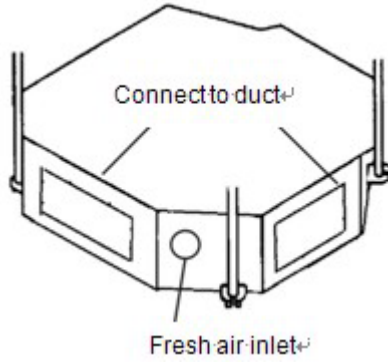

◇ Fresh air ventilation: In the corner of the unit there is a circular fresh air connection hole, if users want this feature, please cut down the circular metal sheet and connect it to the duct. Fresh air hole is connected to the return air inlet of the indoor unit, when operation, the fresh air can be introduced from outside due to the negative pressure.

3.6 Remove Air Filter

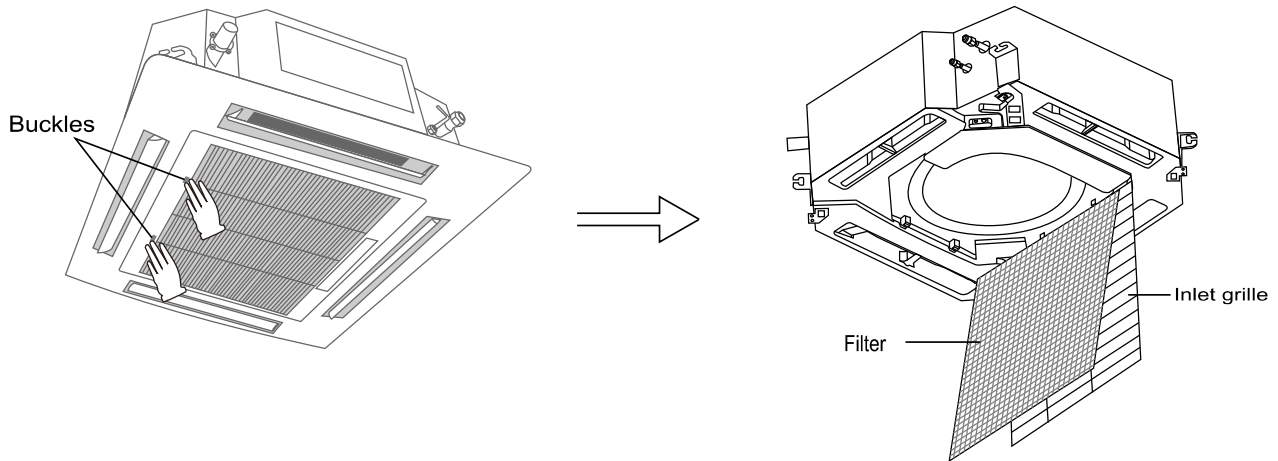

4. Ceiling Floor installation

4.1 Installation spacing

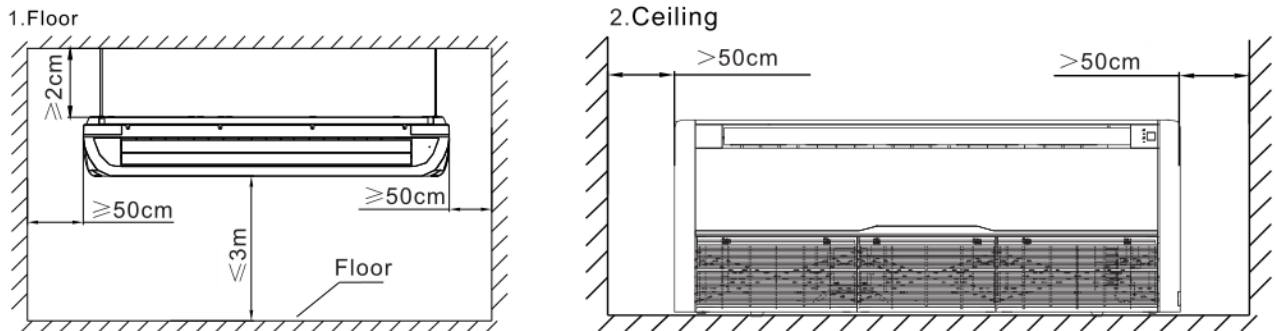

4.2 Indoor unit suspension

- ◇ Select the suspension foundation
- ◇ The suspension foundation is a structure of either wooden frame or reinforced concrete. It must be firm and reliable to bear at least 4 times weight of itself and capable of bearing vibration for long periods;
- Fixing of suspension foundation
- ◇ Fix the suspension bolts either as shown in the picture or by a steel or wooden bracket;

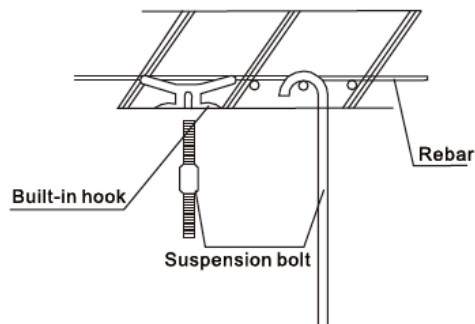

- ◇ Adjust the relative position of the suspension hook on the suspension bolt so that the unit can be in level position in all directions. Check with a level gauge after the installation is complete in order to ensure that the indoor unit is horizontal, otherwise it will cause water leakage, air leakage etc.

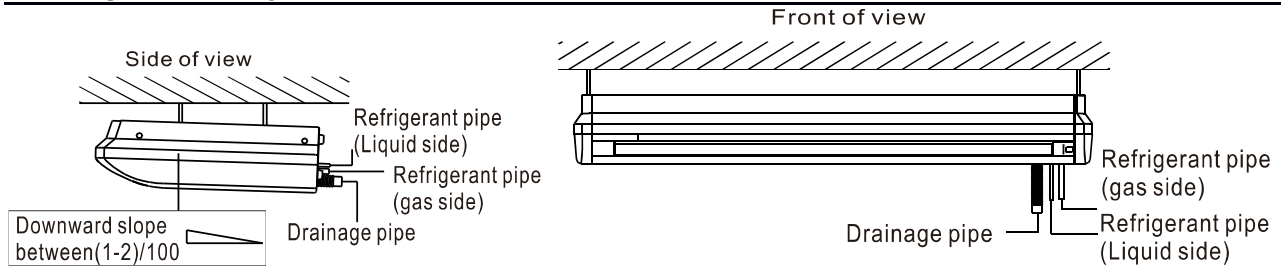

- ◇ Tighten the bolt and ensure that four hooks are in close contact with the nuts and washers, and the unit is suspended firmly and reliably onto the hooks.
- ◇ After the unit is installed ensure it is secure and does not shake or sway.

4.3 Drainage pipe

The drainage pipe should be properly insulated to prevent the generation of condensation. Heat insulation material: the thickness of rubber insulation pipe should be more than 8mm

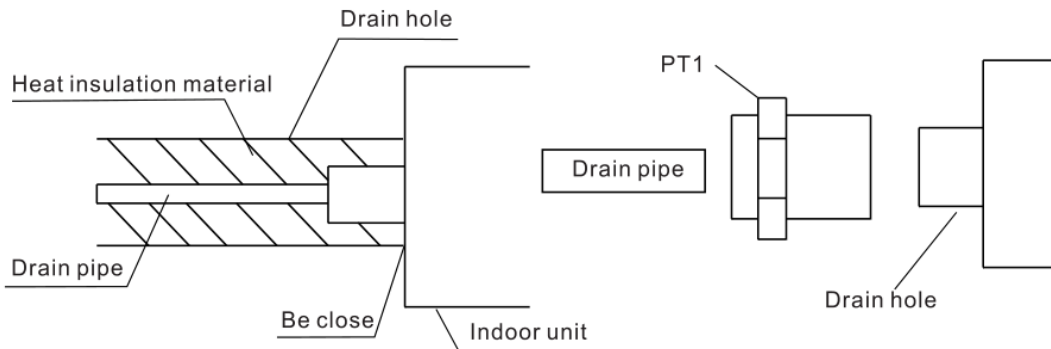

- ◇ Drainage pipe must have a downward gradient (1 / 50 1 / 100). To avoid water backflow or leakage etc.

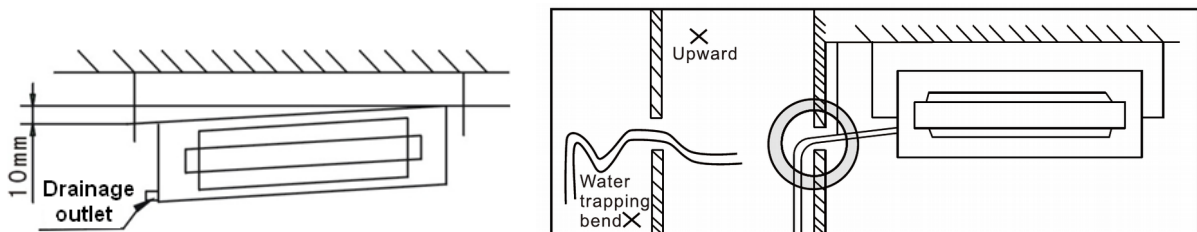

- ◇ When finish installation please carry out the drainage test to ensure that the water flow through the pipeline fluently, and carefully observe the junction to ensure that there is no water leakage at the junction. If the unit is installed in the newly built house, strongly recommend that this test taken before the CFiling installation. Even it is the heating only unit, this test is unavoidable.

5. Duct installation

5.1 Installation spacing

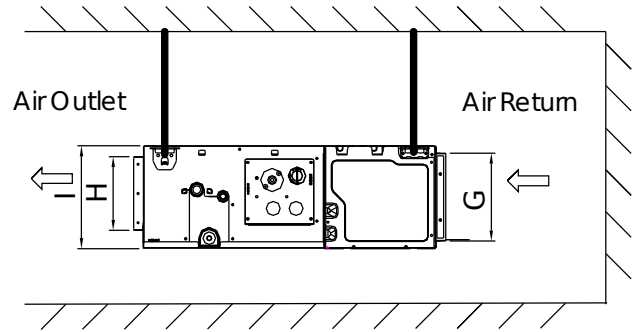
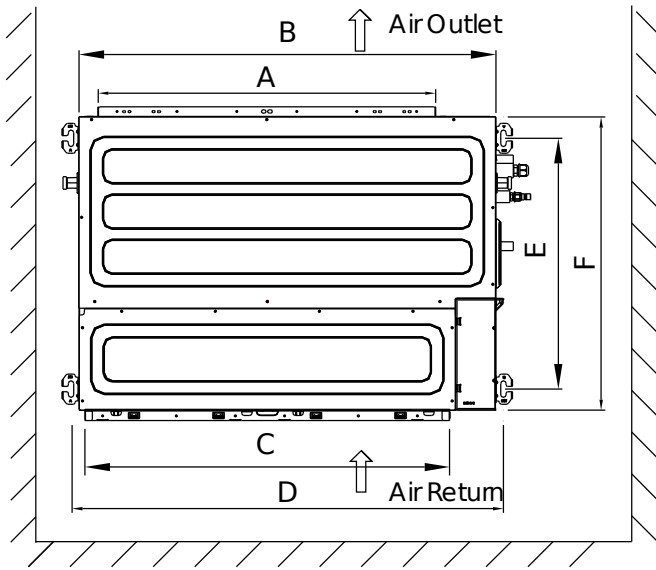

Model	A(mm)	B(mm)	C(mm)	D(mm)	E(mm)	F(mm)	G(mm)	H(mm)	I(mm)
18K 24K 30K	811	1000	874	1039	600	700	208	175	245
36K 42K 48K 60K	1213	1400	1275	1439	600	700	208	175	245

5.2 Indoor unit suspension

Warning :

Must seriously fasten bolts and nuts. The loosening would lead to air conditioner falling and so on.

As shown, the indoor unit should be leaning to the drain hole to be convenient for drainage.

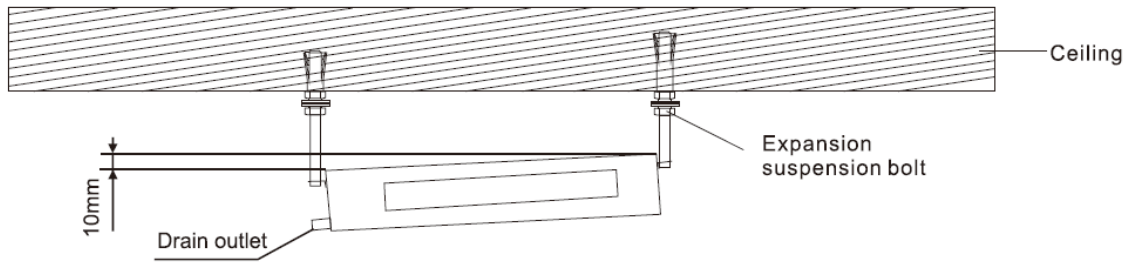

5.3 Installation of duct

There are two installation methods of duct ,as follow.

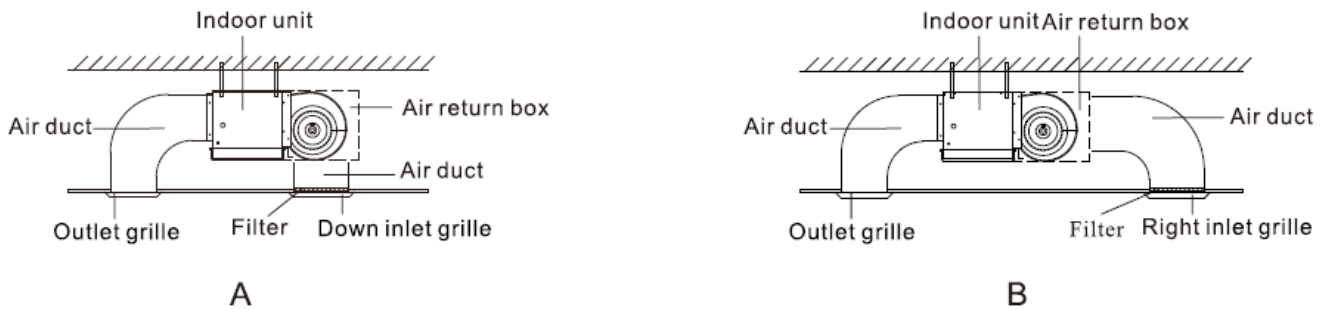

5.4 Drainage pipe

● The drainage pipes should have good insulation measures. The specific steps are as follows:

- The drainage hoses should be tightly clamped with the inner water outlet and the drainage pipe respectively, then fix with a hoop , as shown in Fig1
- Wrap the heat insulation cotton on the drain insulation pipe and the hoop , as shown in Fig 2
- Tighten the sponge with a bandage , as shown in Fig3

R32 High Efficiency DC Inverter LCAC

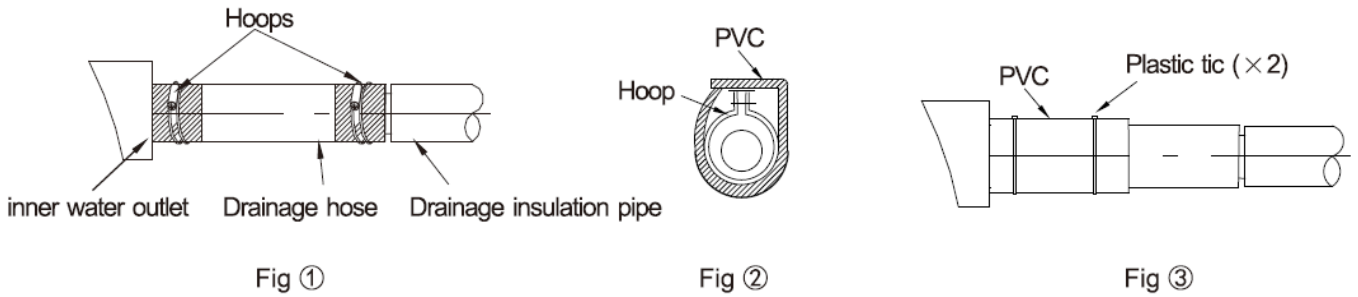

- The drain pipe must have a downward gradient(1/50-1/100).
- If the drain pipe is installed ups and downs or upward,it will lead to water back flow or leakage etc.
- During pipe connection, do not use too much force to the drain joint of indoor unit.
- The joint is PT1.
- There is a drain hole on each side of indoor unit;unused drain pipe must be closed.

Note : The drain pipe must be wrapped heat insulation material, otherwise it will cause condensation or water drops.

Heat insulation material: rubber insulation pipe with thickness more than 8mm.

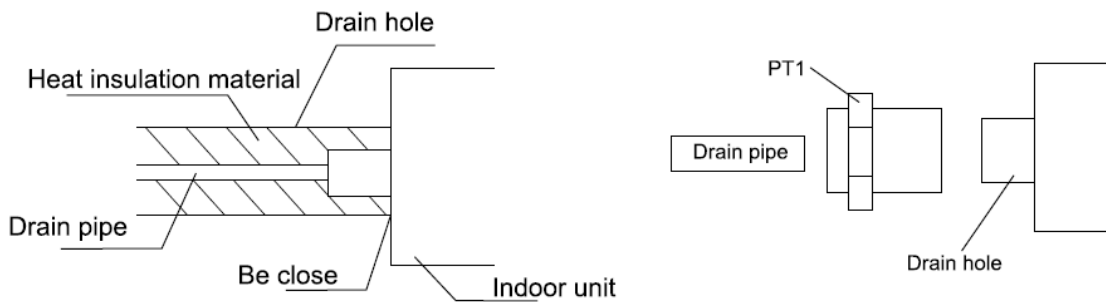

5.5 wired control connection

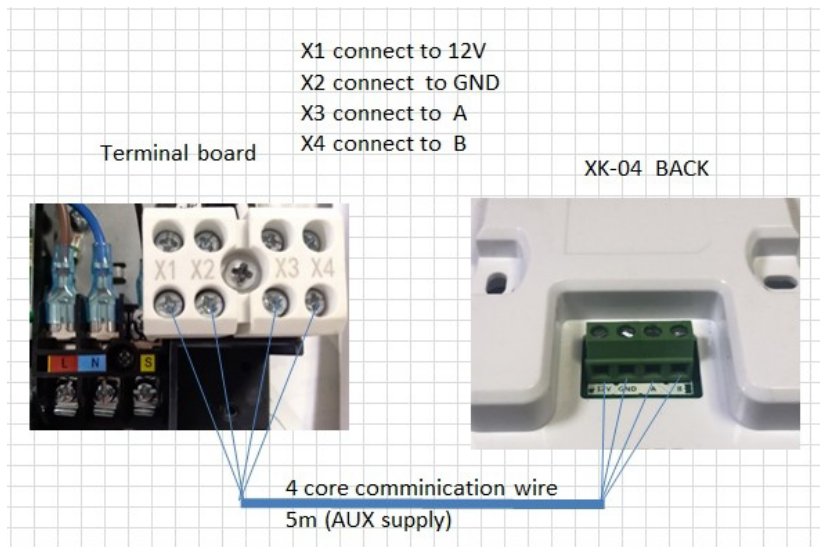

6. Outdoor Unit installation

6.1 Installation location

- ◇The site shall be strong enough to bear its weight, prevent noise and vibration.
- ◇The site shall be ensured to avoid direct sunshine, if necessary set a Have lock above the outdoor unit.
- ◇The site shall be easy to drainage the rain water and the frost water.
- ◇The site shall be ensured that the outdoor unit will not be covered by snow LD ring the winter season.
- ◇The site shall be ensured that the outlet is not facing the strong wind.
- ◇The site shall be ensured that outlet air and operation noise will not affect the neighbors' daily life.
- ◇The site shall be ensured that the outdoor unit will not be affected by the garbage and oil mist.

Warning :

If outdoor unit working under such environment which contains oil (including machine oil) salt(marine areas), sulfide gas (hot springs and oil refinery areas), those substance may lead to the failure work of the outdoor unit.

6.2 Installation spacing

- ◇The site shall be easy for ventilation then the outdoor unit can inhale and discharge air easily. What's more please reserve enough space for maintenance.

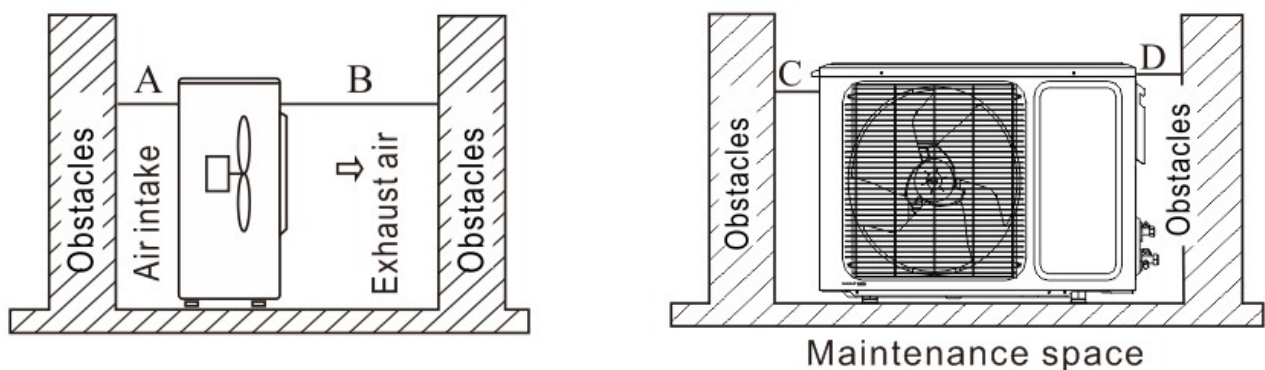

Note: Require A > 300mm; B > 1500mm; C > 300mm; D > 500mm;

6.3 Installation Foundation

- ◇Use size M10 bolt and nut to fasten the outdoor unit tightly on the bracket, keep it in the horizontal level. The suitable length for bolt shall 20mm over the base level, in order to

R32 High Efficiency DC Inverter LCAC

minimize vibration please do set a rubber shock absorber.



◇If the outdoor unit is mounted on the wall or on the rooftop, in order to prevent earthquake and strong wind please fasten it as tightly as possible.

◇Set a drainage channel to ensure the condensing water can drain out smoothly.

◇To avoid that only four angles metal sheet to support the outdoor unit.

Transport

When the outdoor unit is to be lifted, please use two slings longer than 8m and insert cushioning material between the slings and outdoor unit to avoid damaging the casing.

7. Connection piping installation

7.1 Installation precaution

Please choose the phosphorus deoxidation seamless copper pipe as the piping.

◇If use the lengthen piping needs welding:

Please welding before fasten the nut, when welding using nitrogen gas to replace the air in the pipe in order to prevent oxidation.

◇If there are many points to be welded when installing the lengthen piping, please set a filter in the pipe(buy from local market)

◇Please use nitrogen gas or air to remove the dust and water in the pipe,

◇Please lay out the piping according to the tend towards of the piping, but it is not allowed more than 3 times curved at the same point of the pipe(if do like this the pipe will become rigid)

◇Pipe bending machine is used during the process of bending the pipe, the curvature shall not be too small or it will affect the refrigerant flow.

7.2 Specification of connection pipe

Cooling Capacity(KBtu/h)	12K	18K	24K	30K	36K	42K	48K	60K	
Connection Pipe (mm)	Liquid Pipe	Φ6.35		Φ9.52					
	Gas Pipe	Φ12.7		Φ15.88			Φ19.05		
Max. Length	25	30	50	50	65	65	65	65	
Max. Height (m)	10	20	25	25	30	30	30	30	
Max. Bend Qty	5	5	5	8	10	10	10	10	

7.3 Piping specification selection

As to the detail selection please take reference to the cooling capacity adjust index figure during different installation situations.

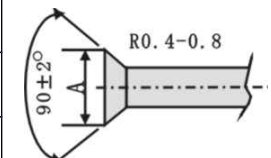
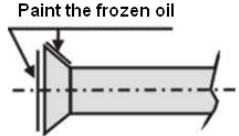
Piping diameter	Tighten	Expanding	Expanding shape	Paint the frozen
1/4in(φ6.35mm)	15-19(N·m)	8.3-8.7mm		
3/8in(φ9.52mm)	35-40(N·m)	12.0-		
1/2in(φ12.7mm)	50-60(N·m)	15.4-		
5/8in(φ15.88mm)	62-76(N·m)	18.6-		
3/4in(φ19.05mm)	70-75(N·m)	22.9-		

7.4 Oil Trap

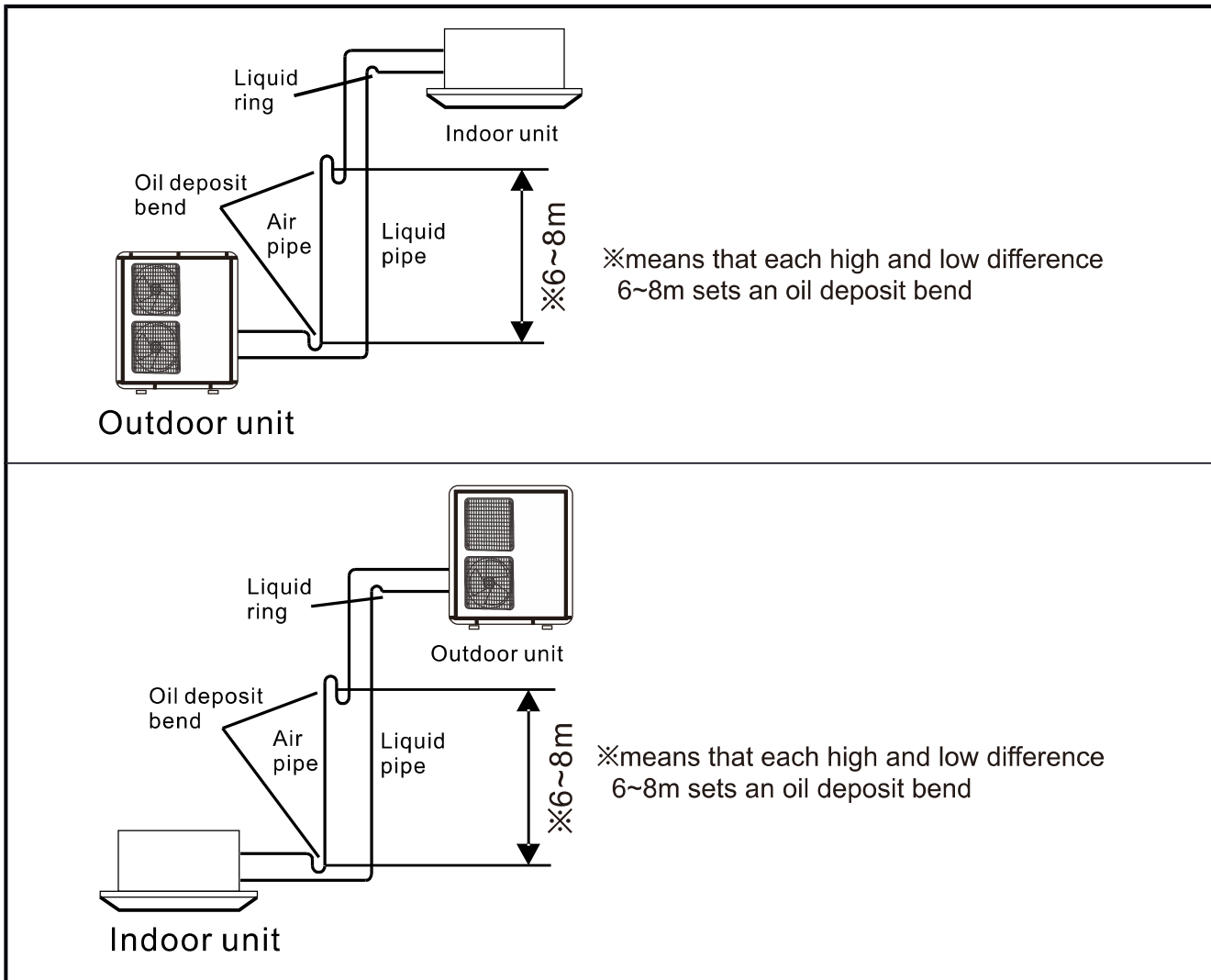

Note:

This chart is for explanation purposes. An actual installation will differ from this according to the site conditions. When making an oil trap the radius of the bend should be between 1.5 and 2 times the pipe diameter.

7.5 Piping connection

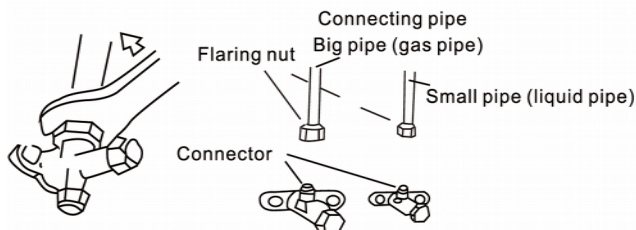

◇Using expanding machine to expand accessories, the size of horn shown in the above figure:

◇Paint a thin layer of frozen oil at both inside and outside part of the expanding.

R32 High Efficiency DC Inverter LCAC

◇Make the expanding right to the screw thread shape connection of the indoor unit, using hands to tighten the nut then using a wrench to tighten the nut again, the tighten torque as follows figure.

7.6 Equivalent pipe length conversion

Equivalent pipe length means converting pipe elbow to straight pipe length after considerate the pressure loss.

Elbow and Oil loop conversion tablet

Type Pipe Dia.(mm)	Bend	Oil Loop
6.35	0.10	0.7
9.52	0.18	1.3
12.70	0.20	1.5
15.88	0.25	2.0
19.05	0.35	2.4
22.02	0.40	3.0

Equivalent pipe length L = ActualPipe length L+ Bend Qty× Equivalent pipe bend length+ Oil Loop Qty × Equivalent Oil Loop length

Sample:

ALCA-H24/NDR3HAA Actual Pipe length is 20 meters, Gas pipe diameter is 15.88mm. If there's 4 bends and 2 oil loops during the installation, then the equivalent pipe length should be:

$$L=20+0.25\times 4+2\times 2=25(m)$$

8. Emptying or Vacuum

Before charging the refrigerant to the system, to ensure that there is no impurities, water or non-condensable gas. So, emptying and vacuum operation should be carried out.

◇Vacuum: when process this operation please be sure that the connection pipe is tightened up.

1. Screw off the cover of maintenance valve connection, connect the pressure gauge to the connection of maintenance valve
2. Connect the vacuum pump to the pressure gauge, turn on the vacuum pump and pressure gauge to process the vacuum operation toward the indoor unit and piping, while to ensure that the absolute pressure is no less than 50Pa after this operation.
3. Turn off the pressure gauge and vacuum pump to keep the pressure in the same level in 20 minutes.

◇Emptying: when process this operation, please disconnect the high pressure valve with liquid valve.

1. Connect the gas valve of the stop valve to the thimble side of the rubber hoses, the other side of rubber hoses should be connected to the refrigerant tank.
2. Open the refrigerant tank valve, using the refrigerant inside the tank with high speed to empty the air in the indoor unit and the connection piping. When the outlet air becomes mist (it feels cold by touching it), then the air is emptied.
3. When ensure that the air is emptied, connect and tighten the high pressure valve of outdoor unit stop valve and liquid side connection pipe, keep this state more than 10 seconds.
4. Use soapy what to test each connection junctions (including lengthen piping welding junction)
5. Confirmed that there is no leakage, turn off the valve of refrigerant tank, take down the rubber hose as well.

◇Turn on the high-low pressure valve of the outdoor unit.

After vacuum and emptying, screw back the cover of the maintenance valve of outdoor unit low pressure valve, screw off the high-low pressure valve of the outdoor unit (note: shall totally turned off). Connect the refrigerant to the system.

9. Insulation

◇ Use heat insulation material with good insulation performance to wrap the pipe.

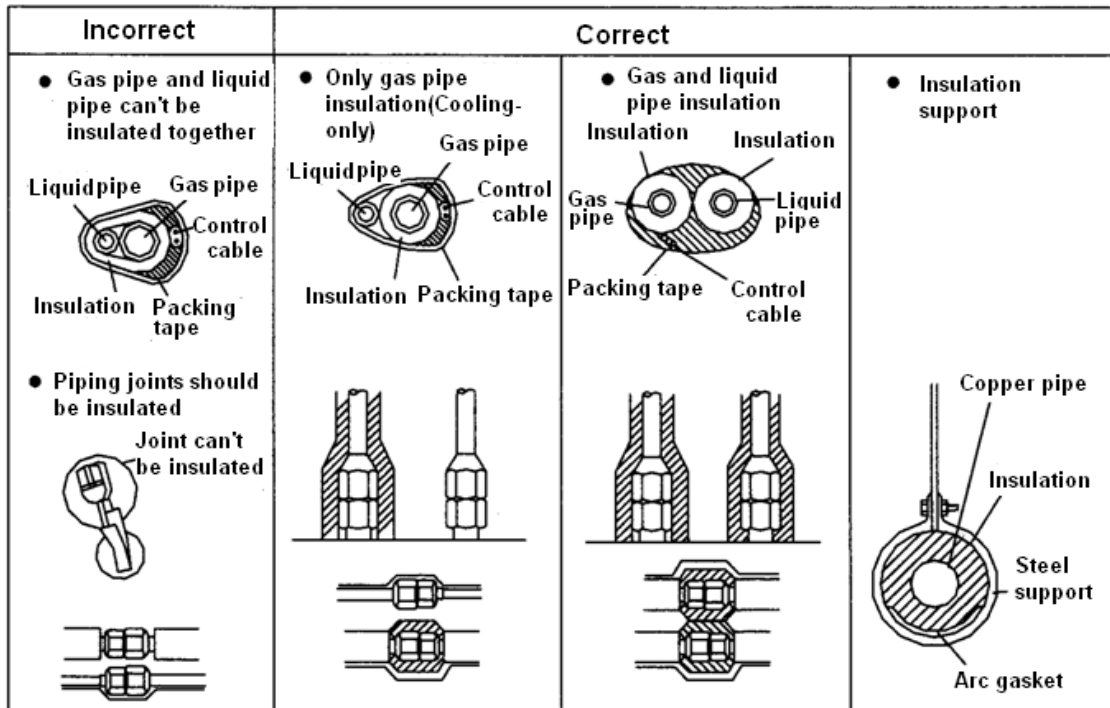

Notes

Drainage pipe and connection piping should be wrapped by heat insulation material respectively or there will be dew or leakage

During the high temperature working environment, our air conditioner is proved my dew conditioner experiment. But if it keeps on working during the high humidity (the dew temperature is more than 23°C) environment which may lead to water leakage, in such condition please use following additional insulation material:

◇ Glass fiber insulation material with the thickness between 10~20mm can be used.

◇ The part of indoor unit which get in touch with the back side of ceiling should pasted with insulation material.

◇ Besides the previously more than 8mm thick insulation material, connection piping (both gas pipe and liquid pipe), drainage pipe should be wrapped by additional 10~30 mm thick insulation material.

To seal the hole on the wall.

◇ To prevent rainwater or other foreign bodies from entering the room and air-conditioner after installing the tubing and drain pipe, the gap between wall hole and tubing, drain pipe and electric wire should be sealed with mastic, sealant rubber or putty, or poor performance or leakage will result

R32 High Efficiency DC Inverter LCAC

◇If the outdoor unit is higher than indoor unit, tubing should be bent to ensure that the lowest point of the tubing is lower than the wall hole to prevent rainwater entering the room or air-conditioner along the piping system.

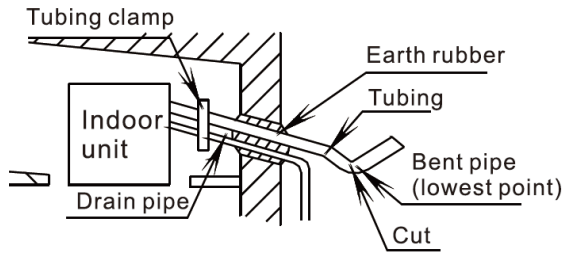

Make a cut in the heat insulation materials of bent pipe (for drainage)

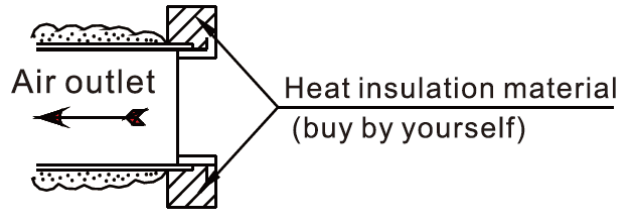

10. Additional refrigerant charge

When pipe length exceeds 5m, please add refrigerant according to the table below:

Connection piping	Capacity	Piping size)		Additional refrigerant charge amount (kg/m)
		Gas pipe	Liquid pipe	
	12K、 18K	$\phi 12.7 \times 1 \text{mm}$	$\phi 6.35 \times 0.75 \text{mm}$	0.02
	24K、 30K、 36K、 42K	$\phi 15.88 \times 1 \text{mm}$	$\phi 9.52 \times 0.75 \text{mm}$	0.04
	48K、 60K	$\phi 19.05 \times 1 \text{mm}$	$\phi 9.52 \times 0.75 \text{mm}$	0.04

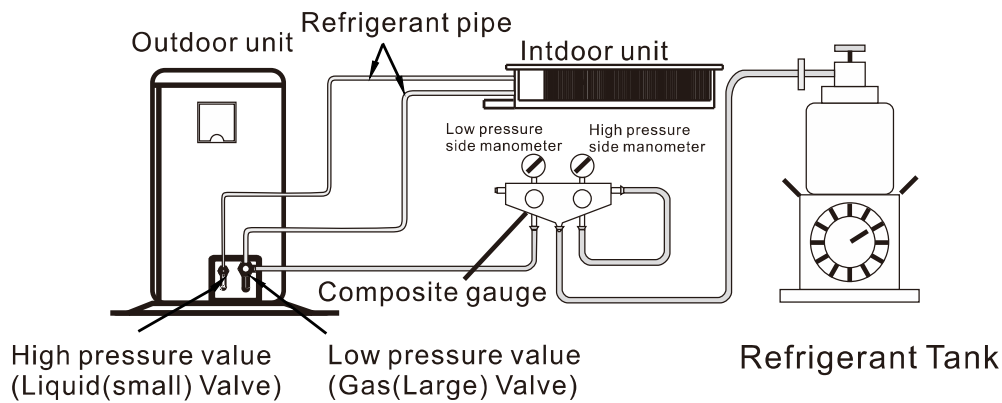

11. Electrical connection

11.1 Electrical connection precaution

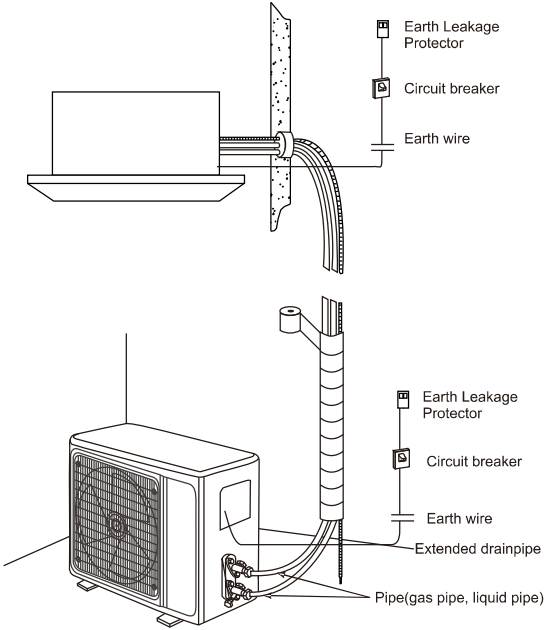
	<p>Warning</p> <p>Installation of electric items must be carried out by qualified, professional technicians. An isolated circuitry should be fixed with whole-pole disconnection devices, which is with at least 3mm gap of touch point. . Power supply and indoor to outdoor connection should use special cable. Providing the necessity of installation or replacement, the professional technician of service store appointed by manufacturer must be required, while self-operation by users is prohibited. In case of any electric shock accident, the creepage protection devices /power supply on-off and breaker must be required with power supply.</p>
---	--

The specification of fuse for single phase control board is F5AL 250V, while for 3 phase control board, both indoor and outdoor unit, it is F3.15AL 250V.

Machine must be earthed surely. If not, it'll be probably caused creepage.

Equivalent 227IEC53(RVV) type of power cord of GB5023 or the excelled must be required. The cords should be fixed properly against broken, while ends/joints of cords is under outside force. Improper connection or fixation will cause disaster like fire....etc. Equivalent 245IEC57(YZW) type of power cord of GB5023 or the excelled must be used as connection line of indoor and outdoor.

Notice

The earth line is neither allowed to connect to gas pipe, water pipe or circuitry of telephone or lighting rod, nor to the earth line of other devices.

Others

Please fix power supply cord and connection wires of indoor and outdoor, in accordance with circuit diagram

Fix the cords into terminal boards properly and safely with cable fixation tools to avoid any danger caused by the power cord under outside forces.

After fixation, use bind tape (affixed) to bind wires avoiding any collision with other components like compressor, copper pipes...etc

11.2 Specification of wire

Wiring Diagram of Indoor Unit and Outdoor Unit

R32 High Efficiency DC Inverter LCAC

Power line must be properly fixed; Outdoor unit must be grounded;

Each indoor unit must be grounded; Power wire must be thickened when it is overlong.

Wiring Diagram of Modular Outdoor Unit

12K,18K,24K,30K,36K,42K(Single phase)

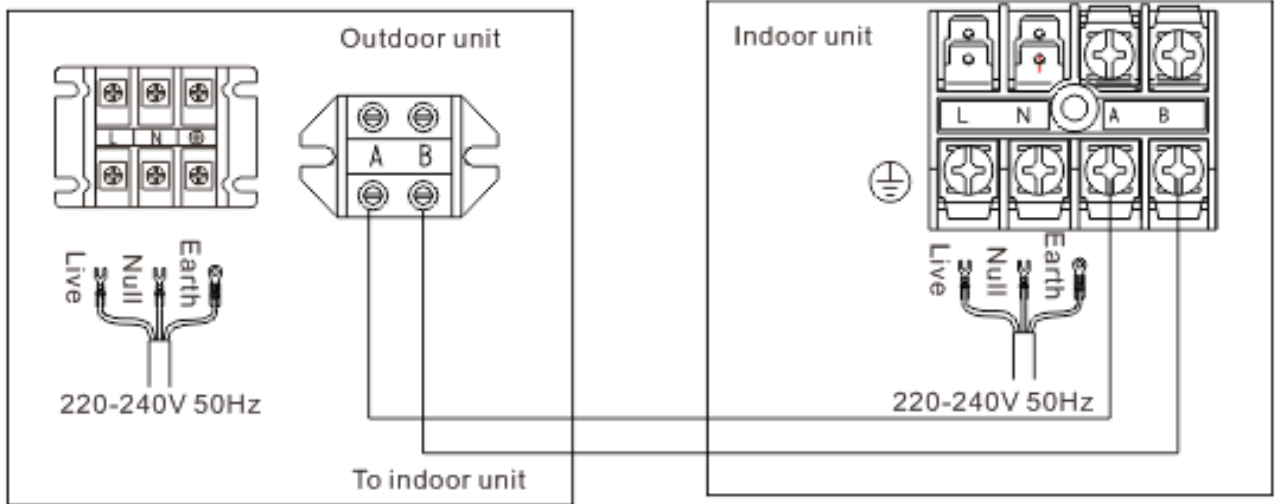

Indoor unit Power wire	Outdoor unit Power wire	Signal wire
3×1mm ²	3×2.5mm ²	2×0.5mm ²

48K,60K(Three phase)

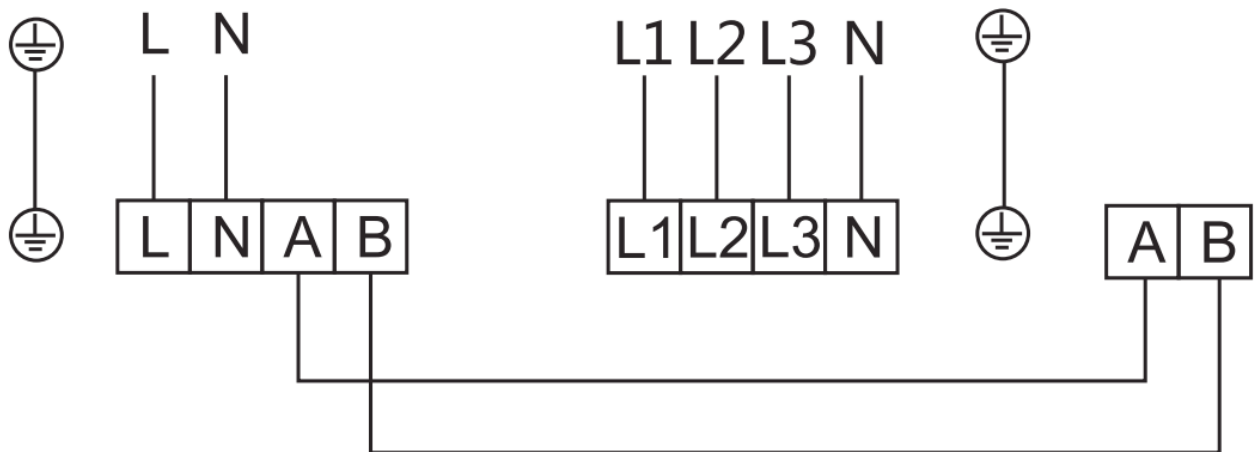

Recommended Specification for Power Line of Outdoor Unit (stand-alone power supply)

Unit Type	Item	Power supply	Power Line (mm ²)	ground wire(mm ²)
Separate power	12K	220~240V 1Ph ~ 50Hz	3*2.5	2.5
	18K		3*2.5	2.5
	24K		3*2.5	2.5
	30K		3*2.5	2.5
	36K		3*2.5	2.5
	42K		3*2.5	2.5
	48K	380~415V 3Ph ~ 50Hz	5*2.5	2.5
	60K		5*2.5	2.5

Outdoor wire connection

- ◇ Remove the electric item cover, which is positioned in the right side of outdoor unit, connect the wires in accordance with the electric diagram on the back of the cover.
- ◇ Be sure that pressing the wires tightly with the terminal boards while it through the board, the wire ends must be tightly fixed into terminal boards. The earth wire must be fixed into appointed position.
- ◇ After all the wire connected, bundle connection pipe, connection wires and drainage pipewith strips like mentioned drawing below:

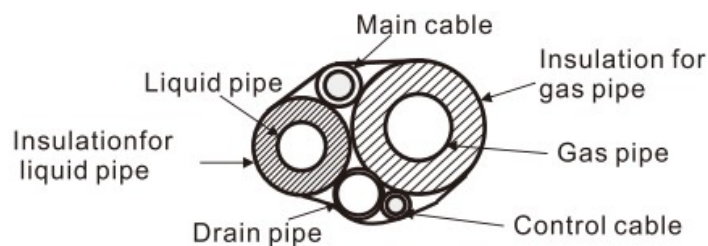

Notice:

- ◇ Be sure do't make the drainage pipe flat while bundled.

Commissioning

Check installation condition

- ◇ Check indoor/outdoor unit installation and wire connection in accordance with the requirement of service manual.

R32 High Efficiency DC Inverter LCAC

- ◇ Check the power supplying, diameter of wires, air on-off and make it sure that the items can be matched with machines and, earth wire connection safety.
- ◇ Check air inlet/outlet duct and make it sure that the items is clean, operating smoothly.

Commissioning

- ★ The system should be power on for 8 hours for preheat before the first time start up..
- ★ During winter, while after 8 hours power off, the performance test should be 2 and half hours power on later:
 - ◇ Power on the system and start up, r cooling mode.
 - ◇ After 3 minutes compressor protection, check whether there is normal cooling air come from indoor unit and if there is abnormal noise come from indoor/outdoor units
 - ◇ Configure the mode with “fan” and check whether there is high air come from indoor unit.
 - ◇ Operate “swing” mode, check whether the louver is properly swaying.
 - ◇ Press the other buttons on the remote controller and check whether the complete unit is on proper working condition
 - ◇ Keep on running for 1 hour with “cooling” mode and check if the drainage system is on proper condition
 - ◇ Switch the mode for “heating” and check whether there is warm air flow come from indoor unit, whether there is abnormal noise come from indoor/outdoor units
 - ◇ After confirmation of normal working condition, press the “on-off” button to stop the system.
 - ◇ At last, train the end users with operation, maintaining and special notice.

Part12 PCB Instruction

1. Outdoor Unit PCB

1.1 12K,18K,24K

Mian PCB and Driver modular

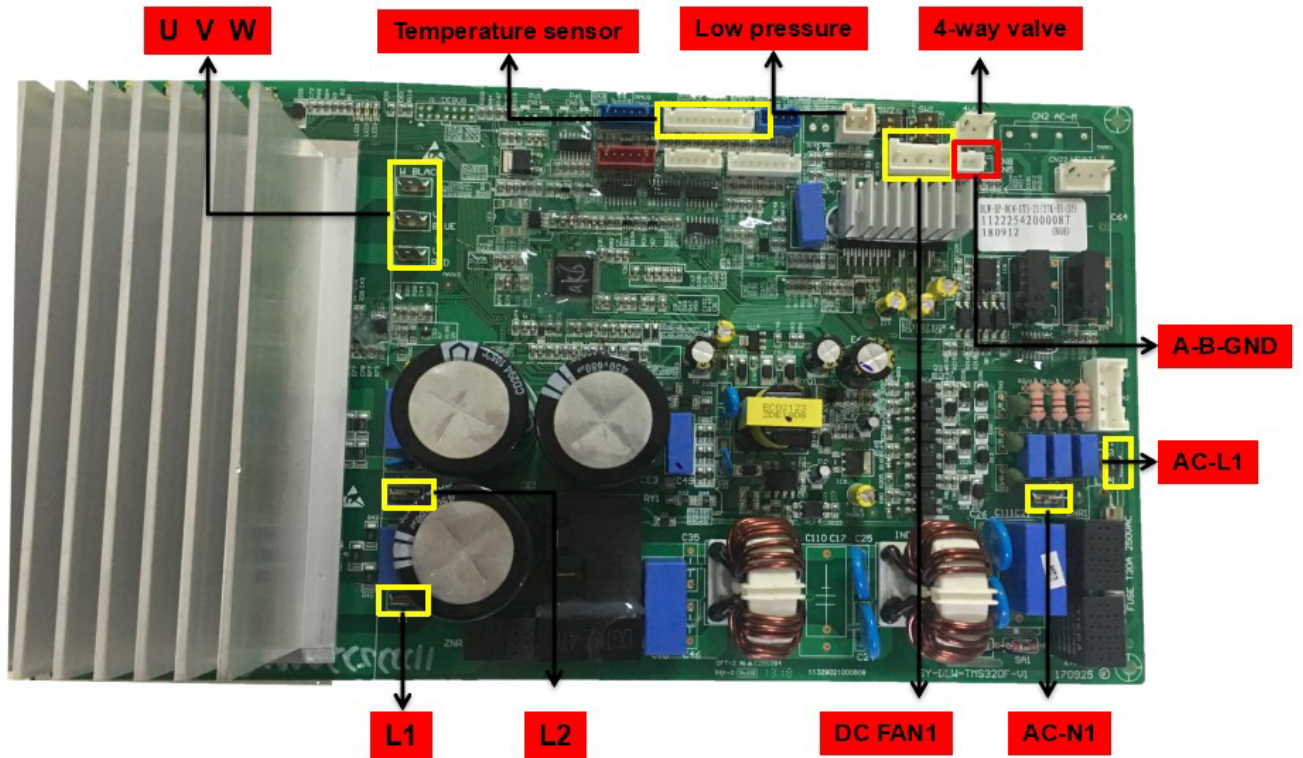

R32 High Efficiency DC Inverter LCAC

1.2 30K,36K, 42K

Main PCB

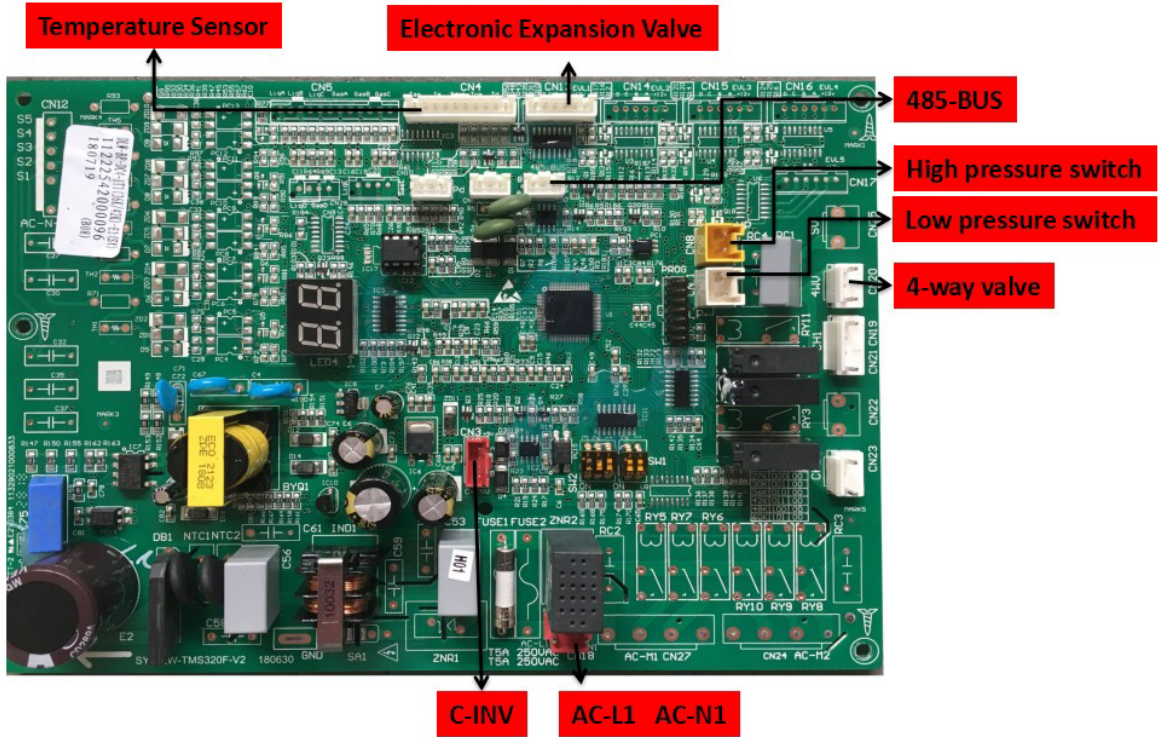

Drive Modular Board

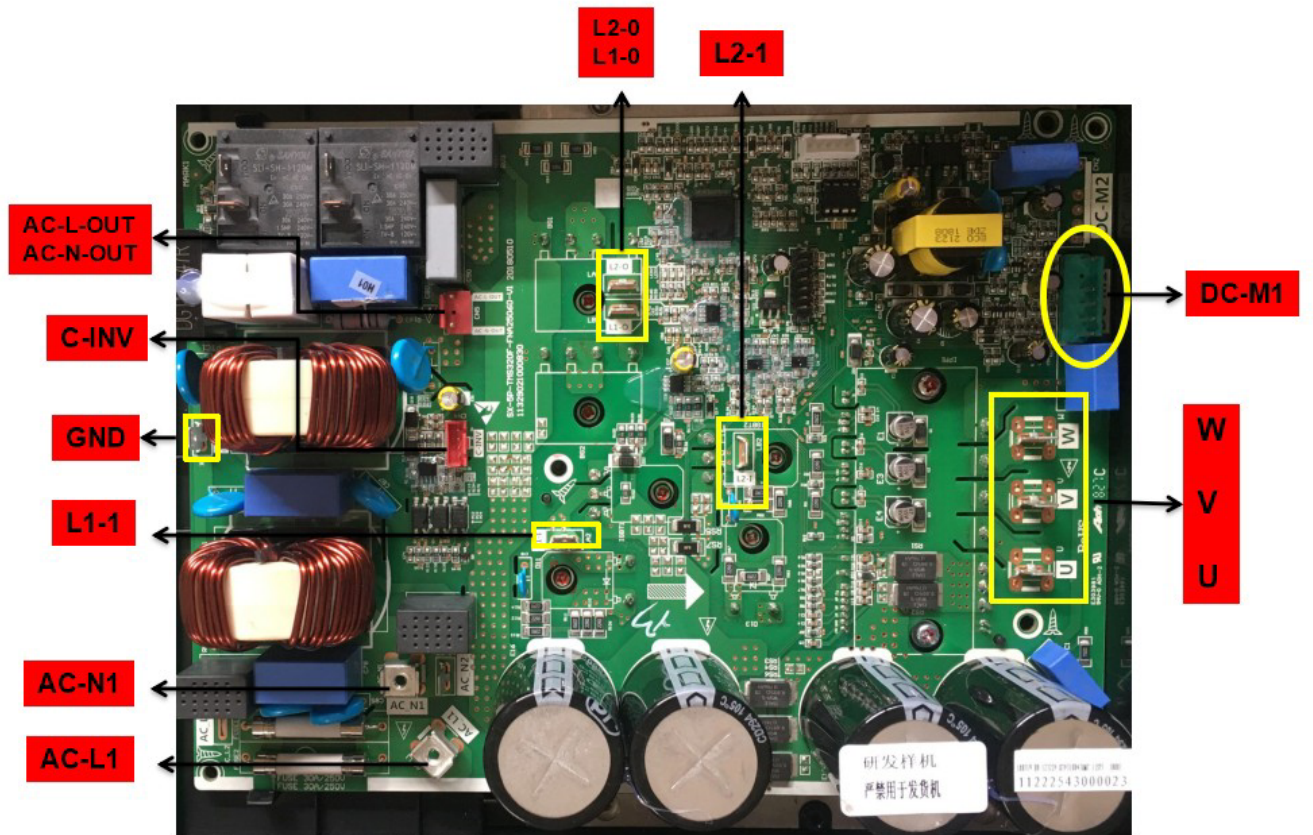

R32 High Efficiency DC Inverter LCAC

1.3 48K,60K

Main PCB

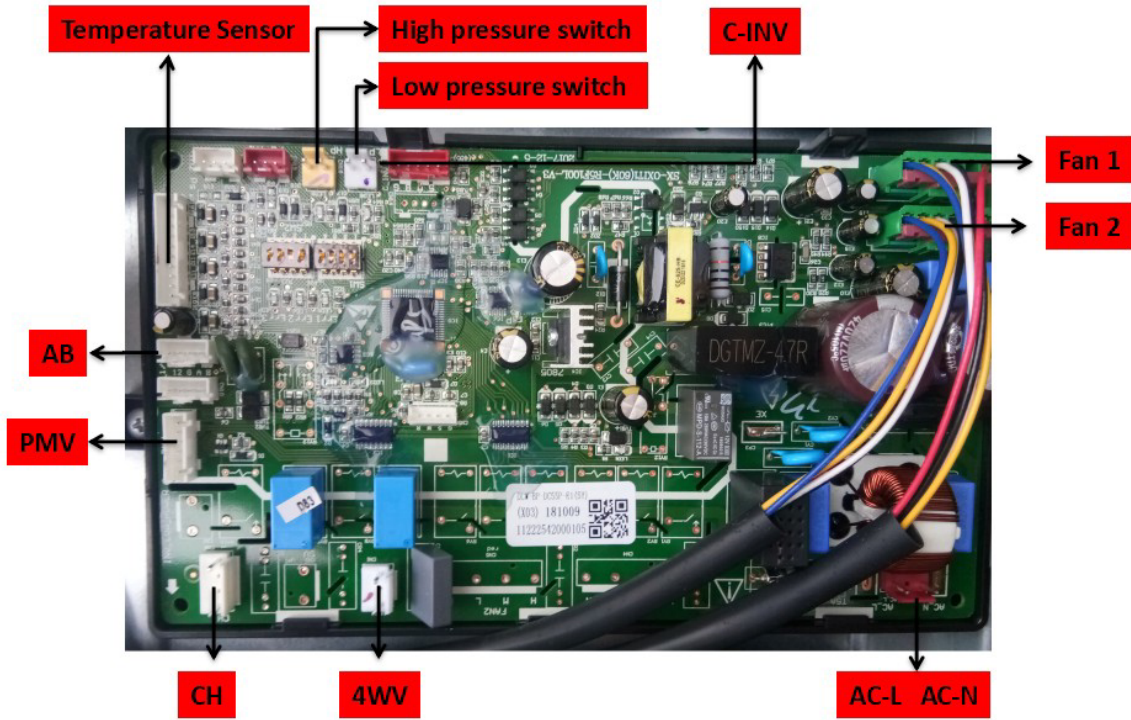

Drive Modular Board

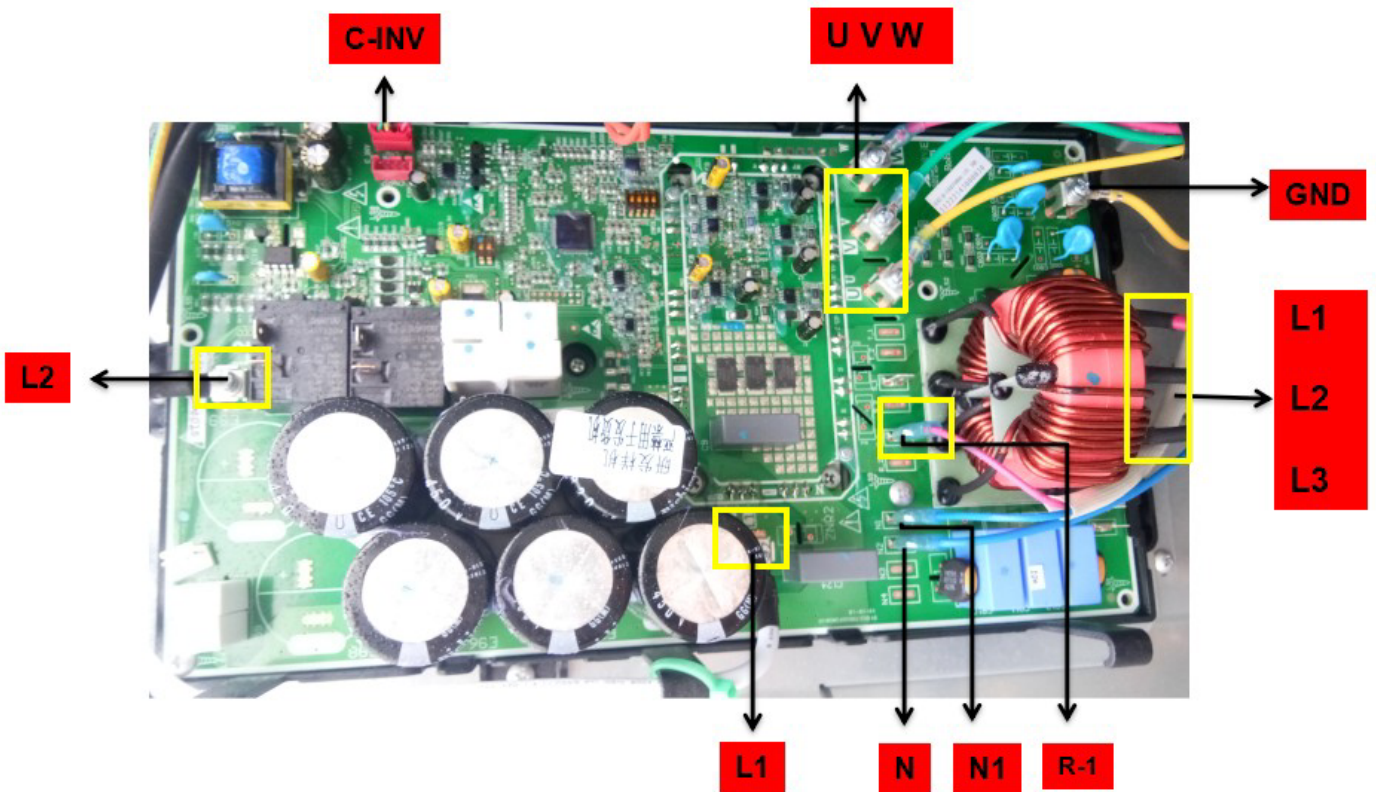

2. Indoor Unit PCB

2.1 12K~60K (Cassette,Ceilling&Floor)

Main PCB

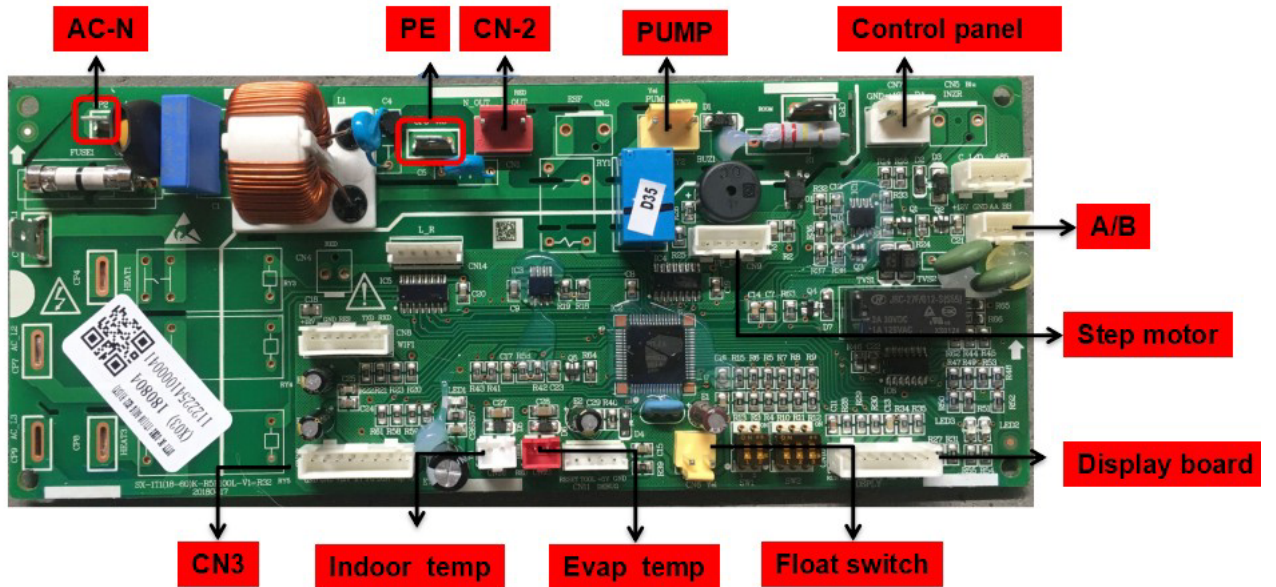

Driver Modular

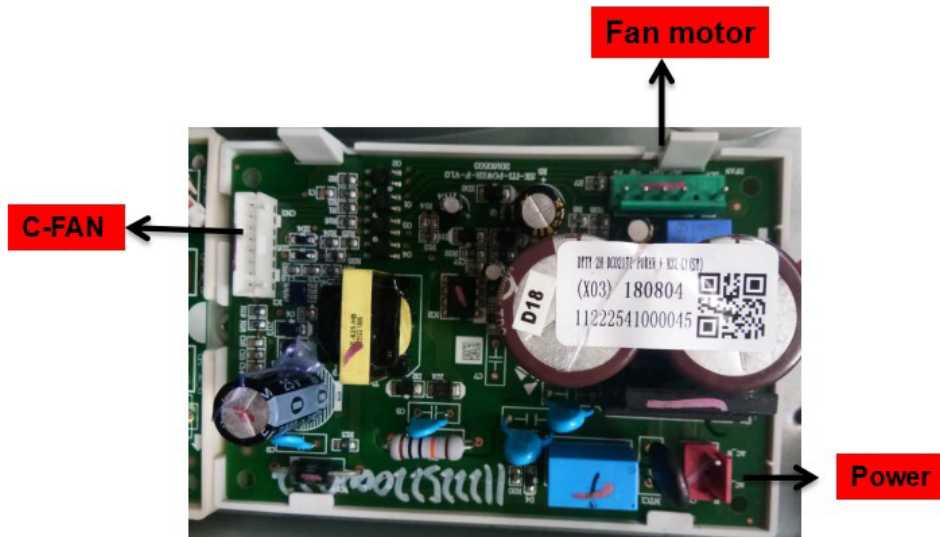

2.2 12K~60K(Duct)

Main PCB

R32 High Efficiency DC Inverter LCAC

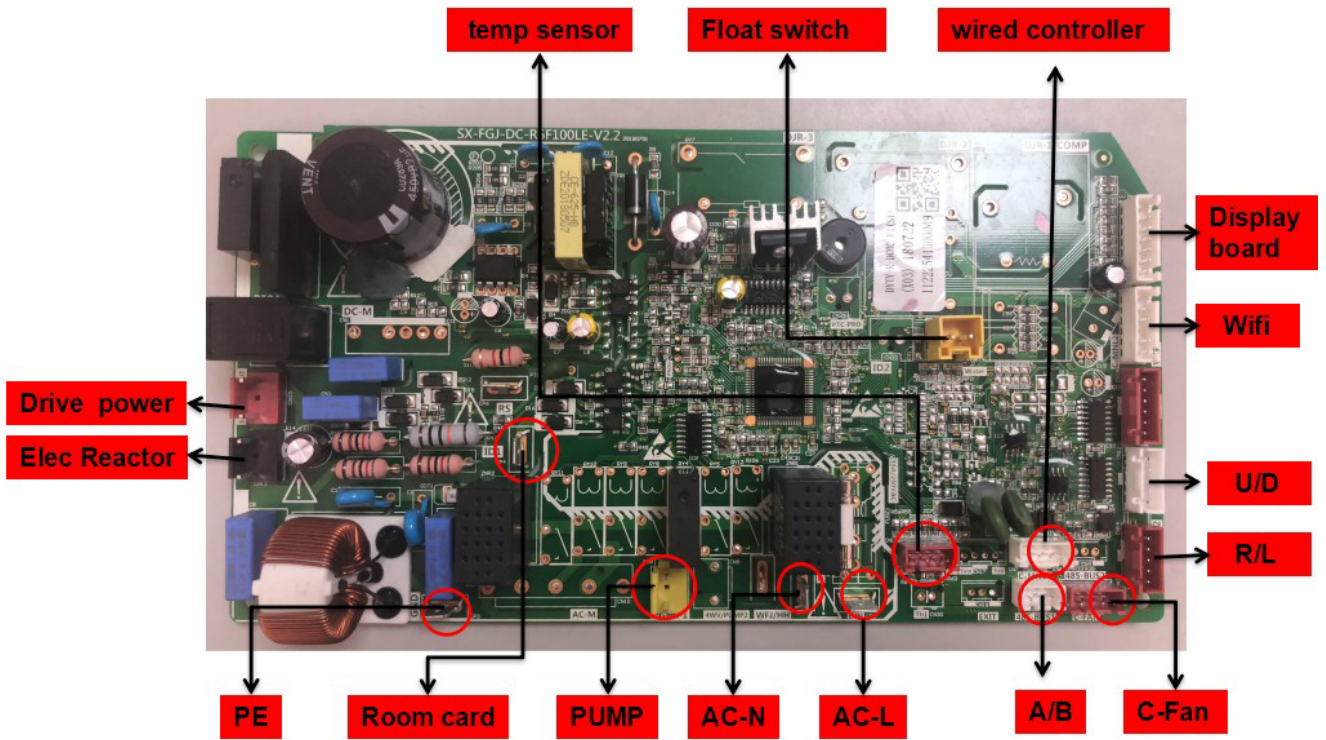

Driver Modular

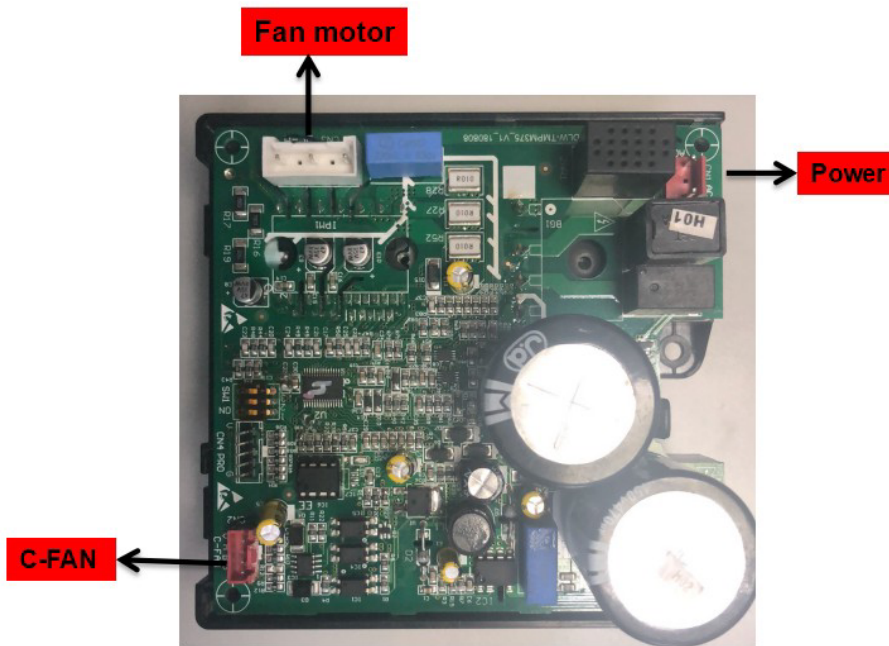

Part13 Trouble Shooting

1. Failure code display

SN	ERROR CODE (display board) (wired controller)	DESCRIPTION
1	31	Fault with the inverter module protection
2	35	Fault with the over-electric current protection
3	36	Fault with the over-voltage or low voltage protection
4	38	Fault with the Compressor Power supply Phase deficiency protection
5	3E	Fault with the compressor start
6	3H	Fault with the Fan motor of outdoor unit
7	A1	Fault with the room temperature seneor(Tico) on the indoor unit
8	A2	Fault with the temperature seneor(Ticm) on the indoor unit
9	A5	Fault with the drainage
10	A6	Fault with the Fan motor of indoor unit
11	A9	Communication error between the outdoor unit and the indoor unit
12	AA	Communication error between the wired controler and main PCB of the indoor unit
13	AJ	Fault with anti-Frozen protection of indoor unit in heating model
14	C1	Fault with the Enviromental temperature seneor(Tao) on the outdoor unit
15	C3	fault with the discharge temperature sensor
16	C6	fault with the suction temperature sensor
17	C8	Fault with the temperature seneor(Tcm) on the outdoor unit
18	E1	fault of four way valve
19	E3	Protection high temperature discharge
20	E8	Fault with anti-high temperature protection of indoor unit in heating model
21	F6	fault with the low pressure
22	FH	Protection lower temperature discharge
23	H1	fault with the High pressure switch
24	H4	fault with the low pressure switch
25	J3	Communication error between the driver PCB and main PCB of the outdoor unit
26	J6	Communication error between the driver PCB and main PCB of the indoor unit
27	J7	Fault with the outdoor unit EPROM

2. Failure analysis

2.1 [AA] Wired controller communication failure

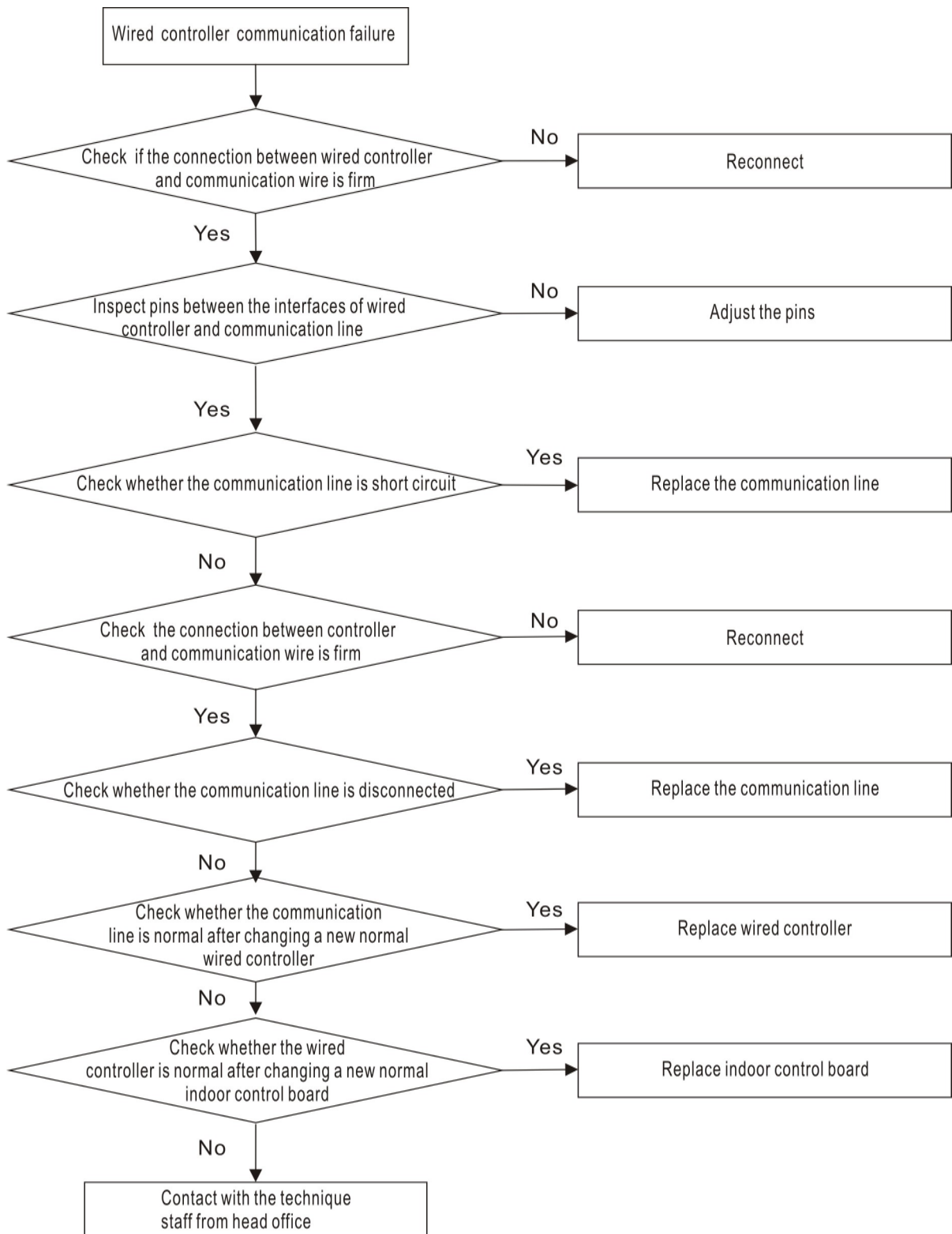

2.2 [A9] Communication failure between indoor and outdoor unit

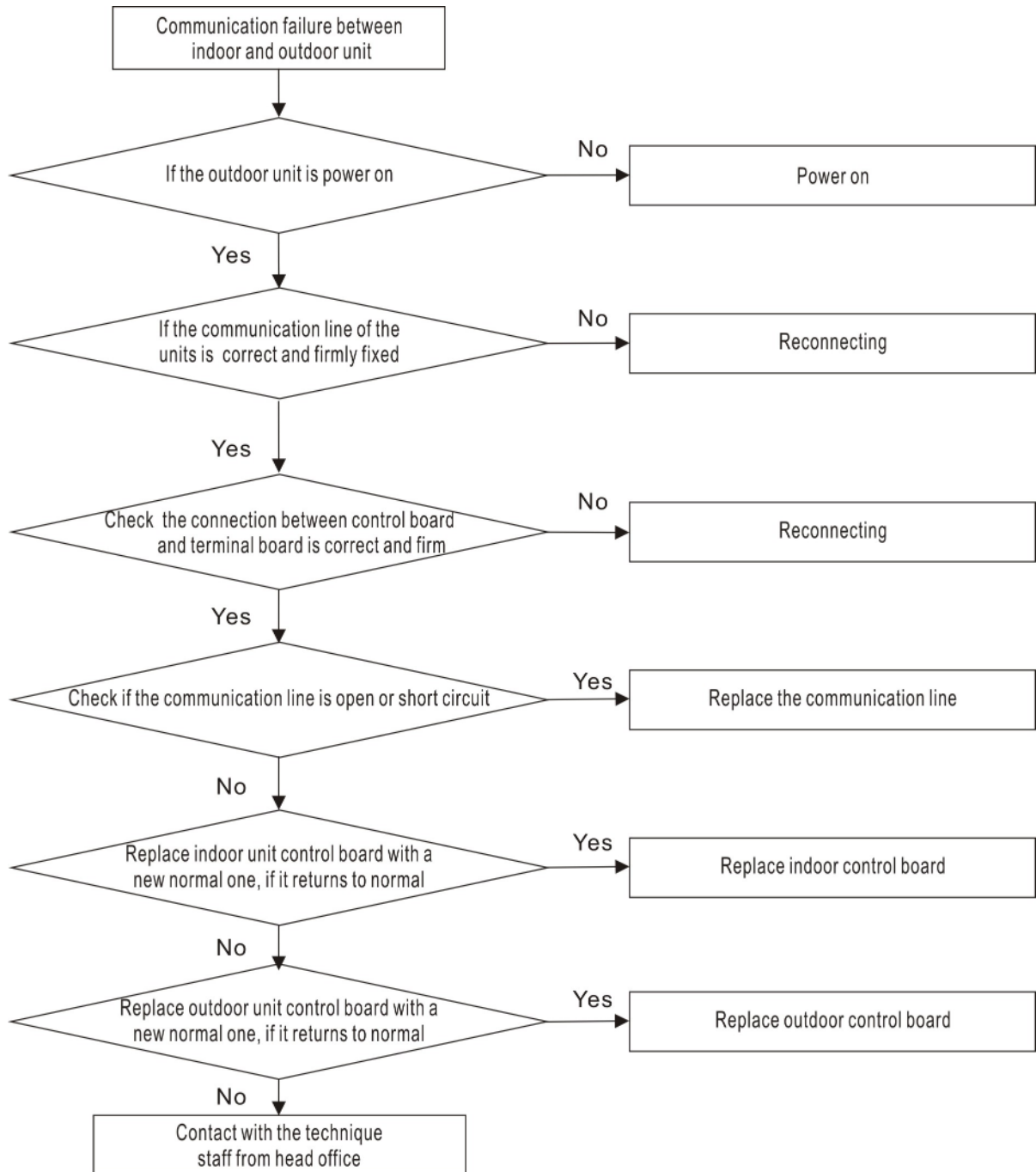

Outdoor protection(phase sequence)

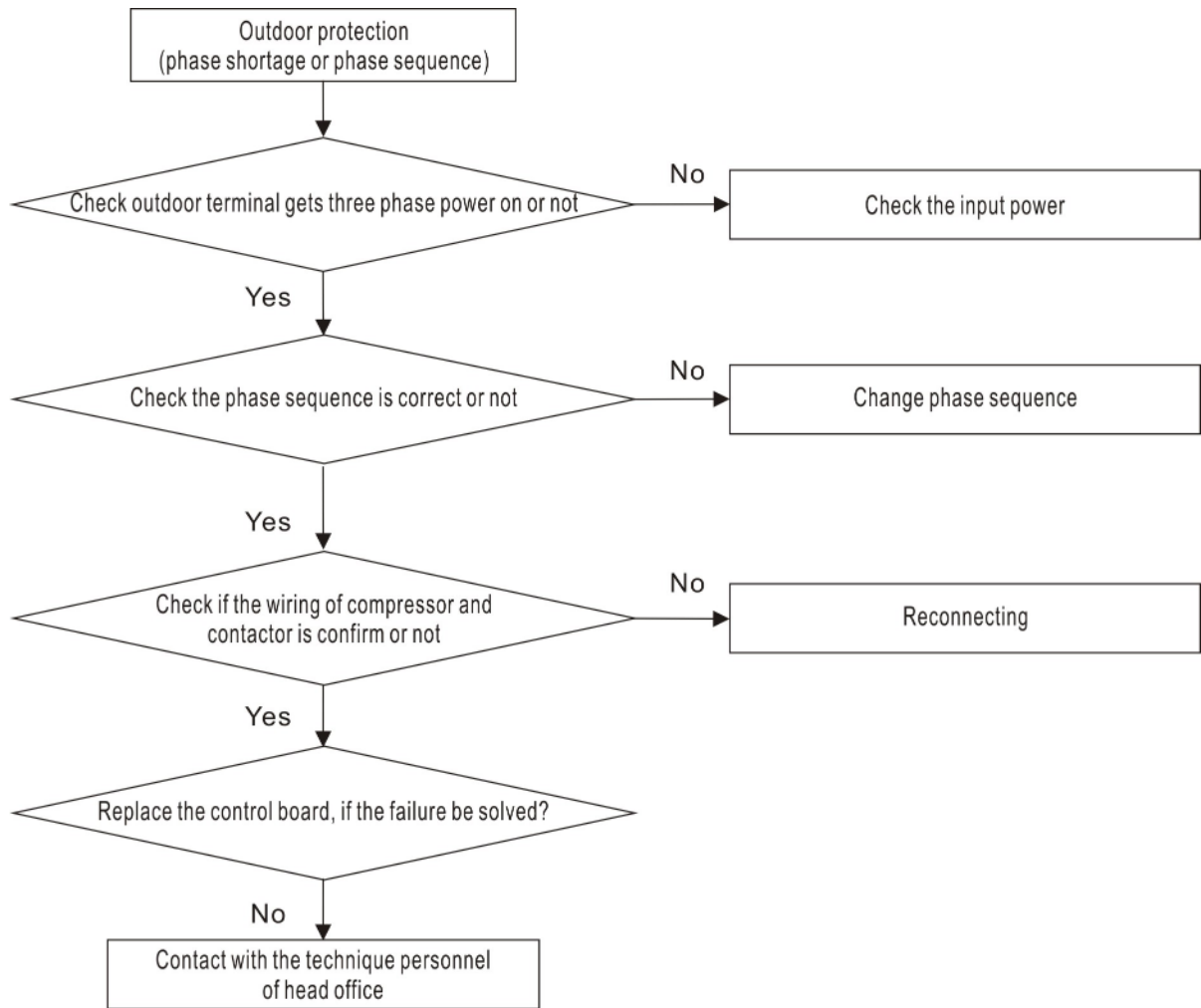

2.3 【H1】 high pressure protection

Cooling high pressure protection

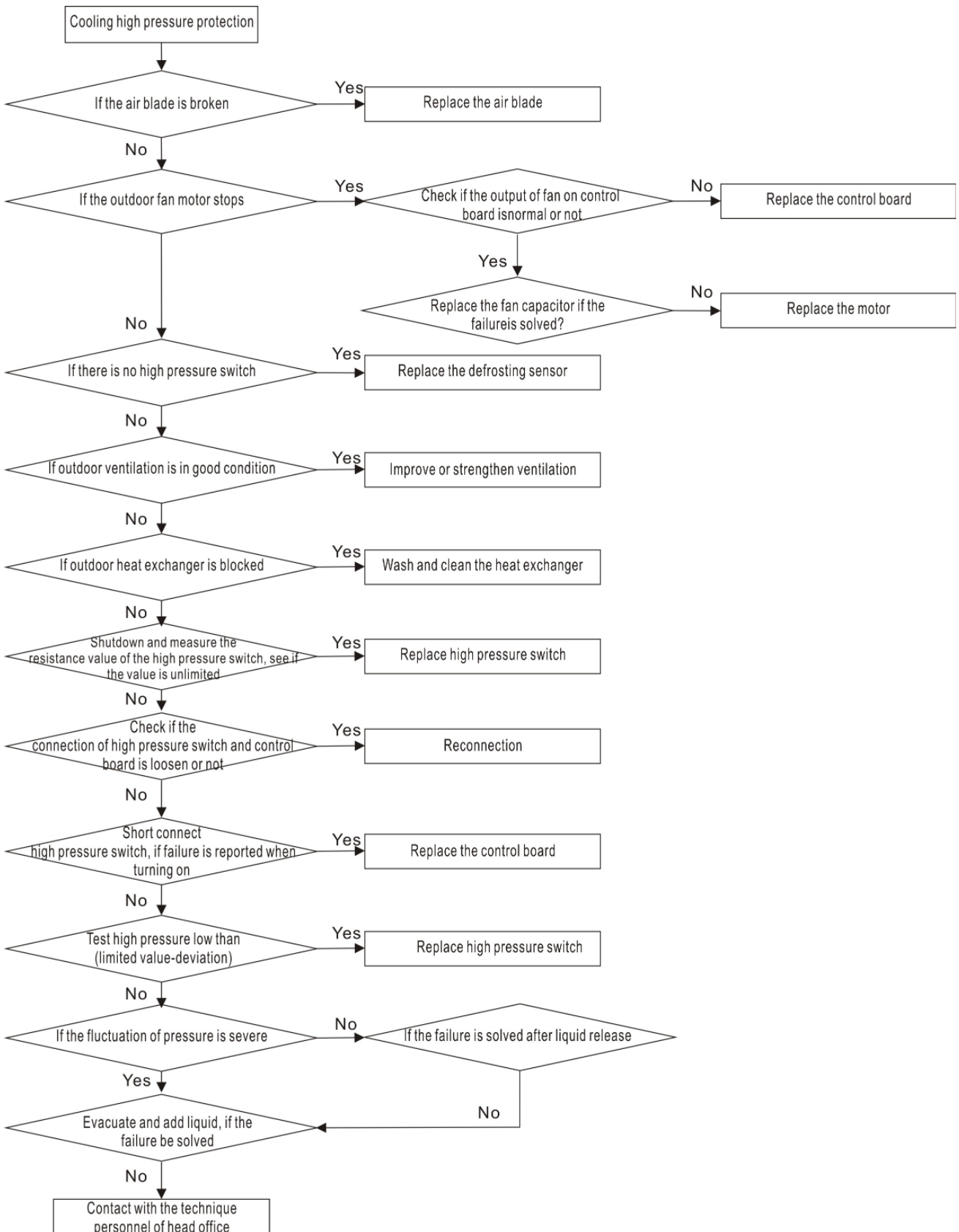

Heating high pressure protection

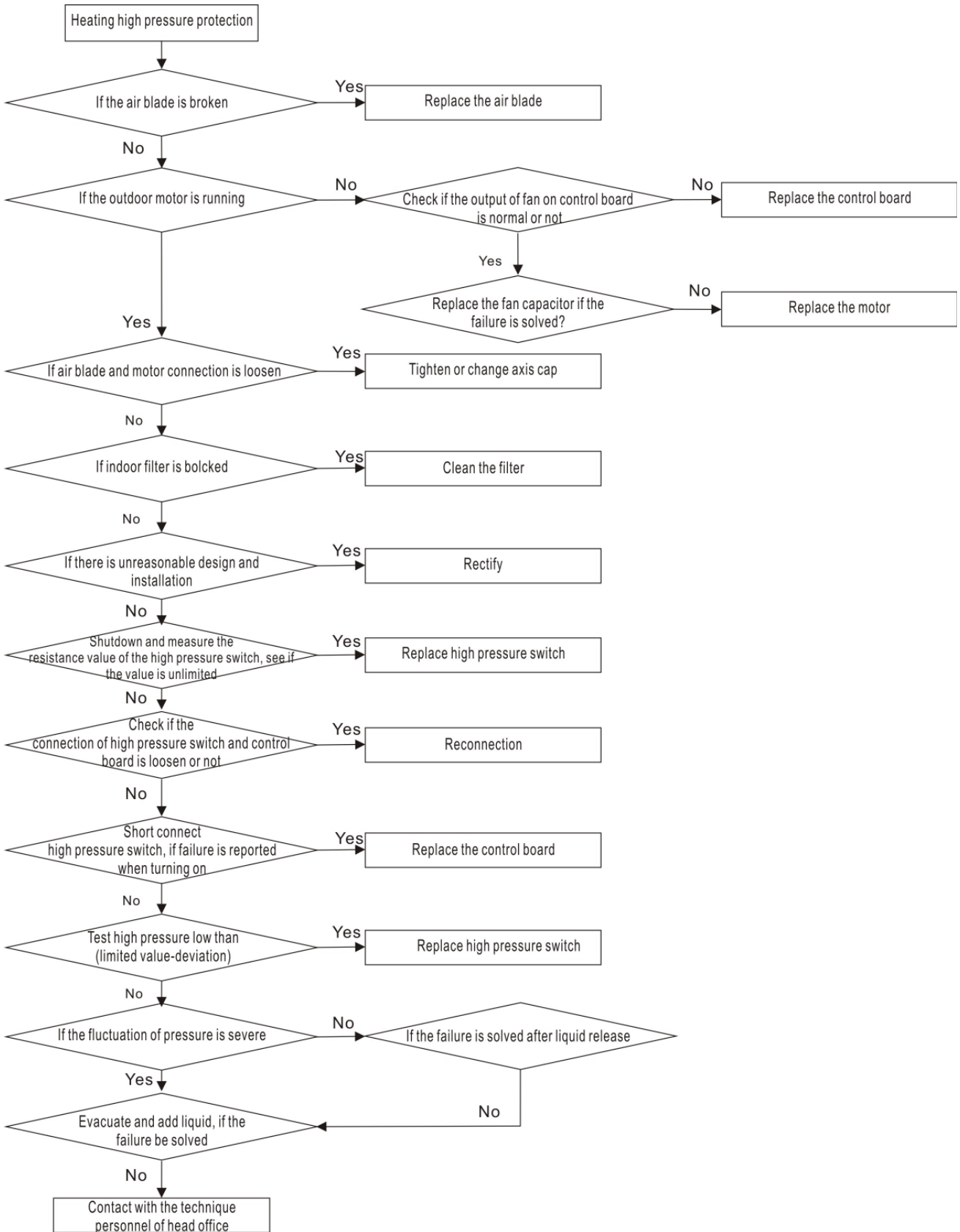

2.4 [H4] low pressure protection

2.4.1 Cooling low pressure protection

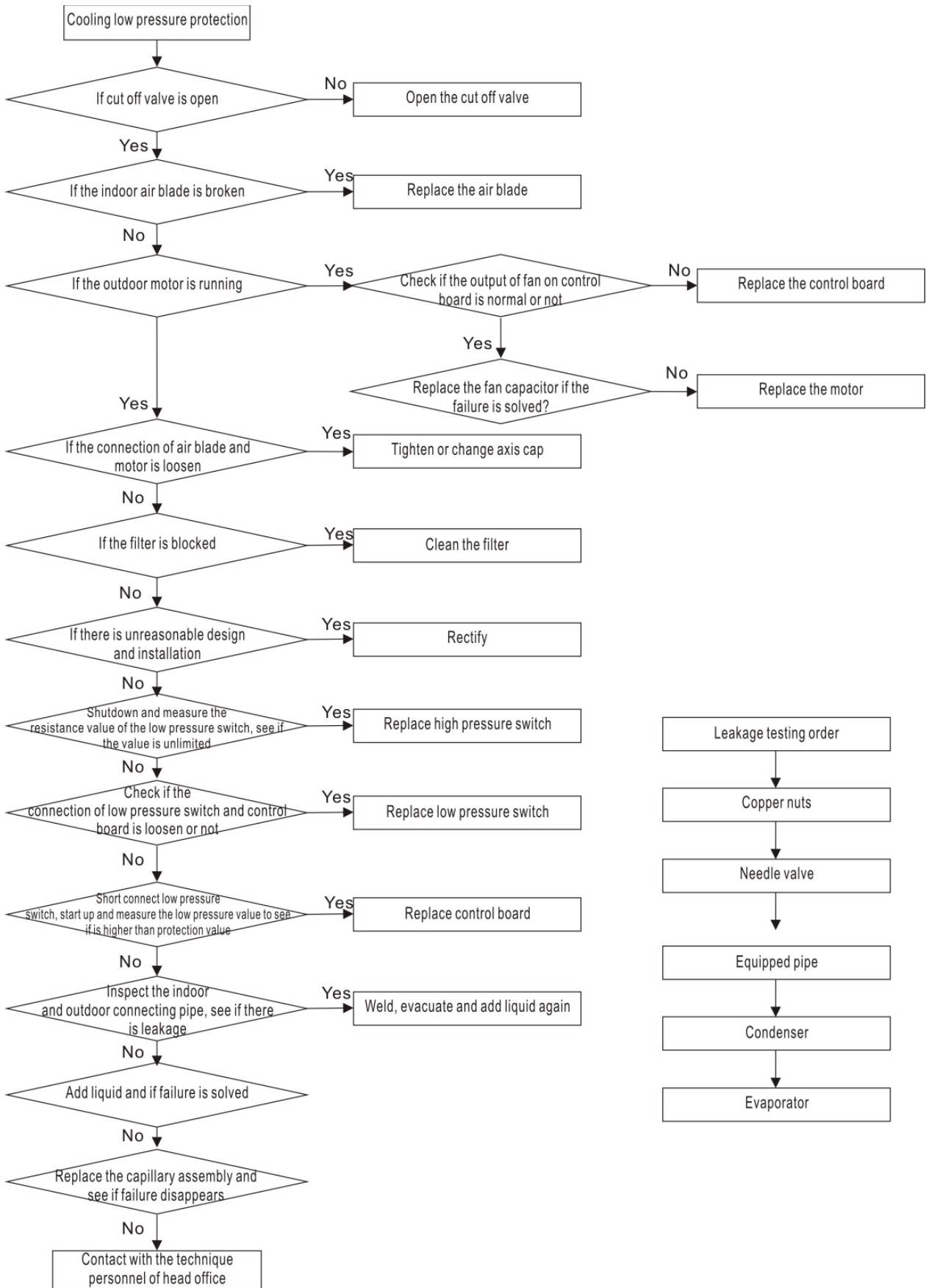

2.4.2 Heating low pressure protection

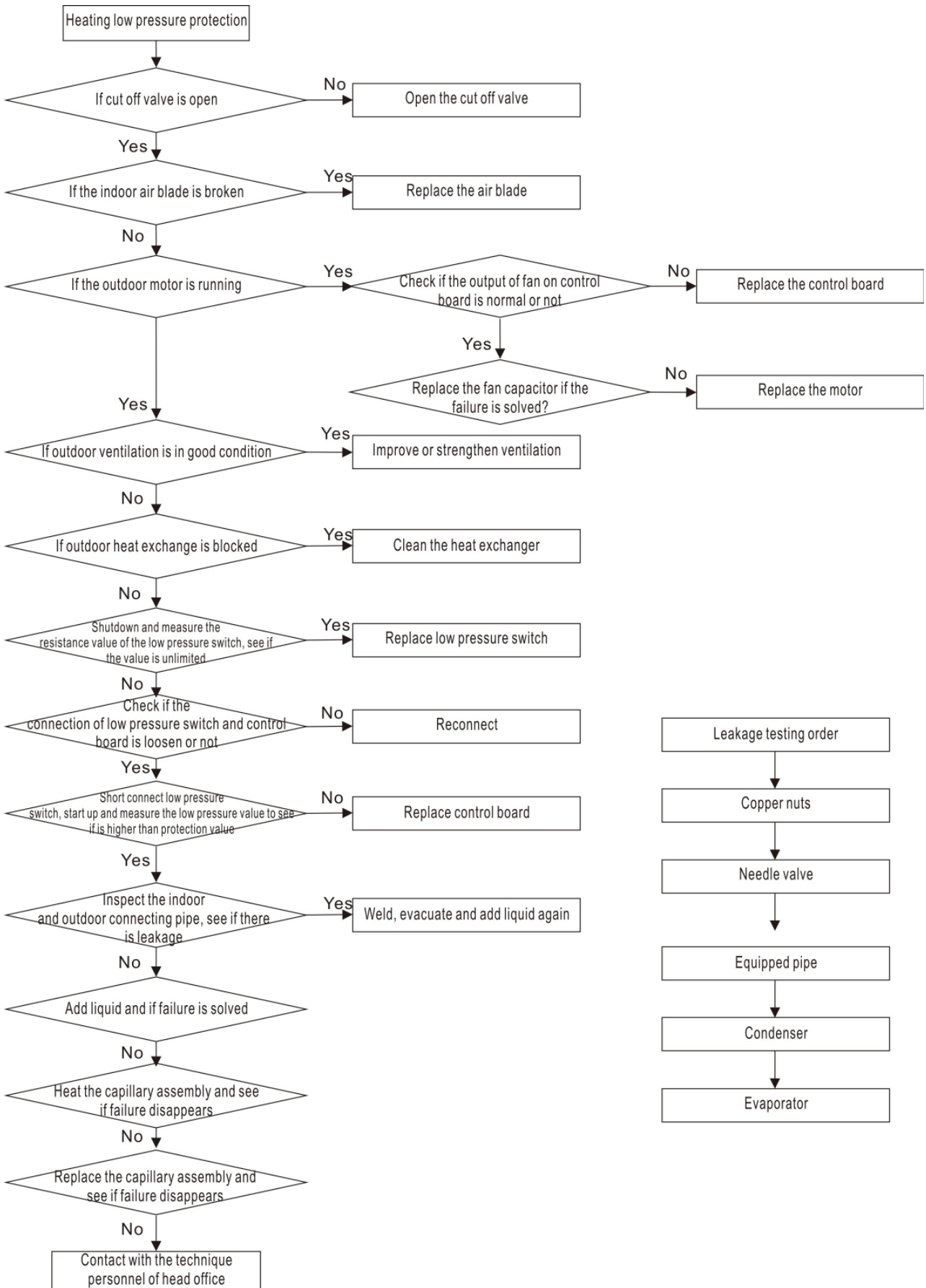

2.5 [E3] High exhaust temperature protection

Cooling exhaust temperature protection

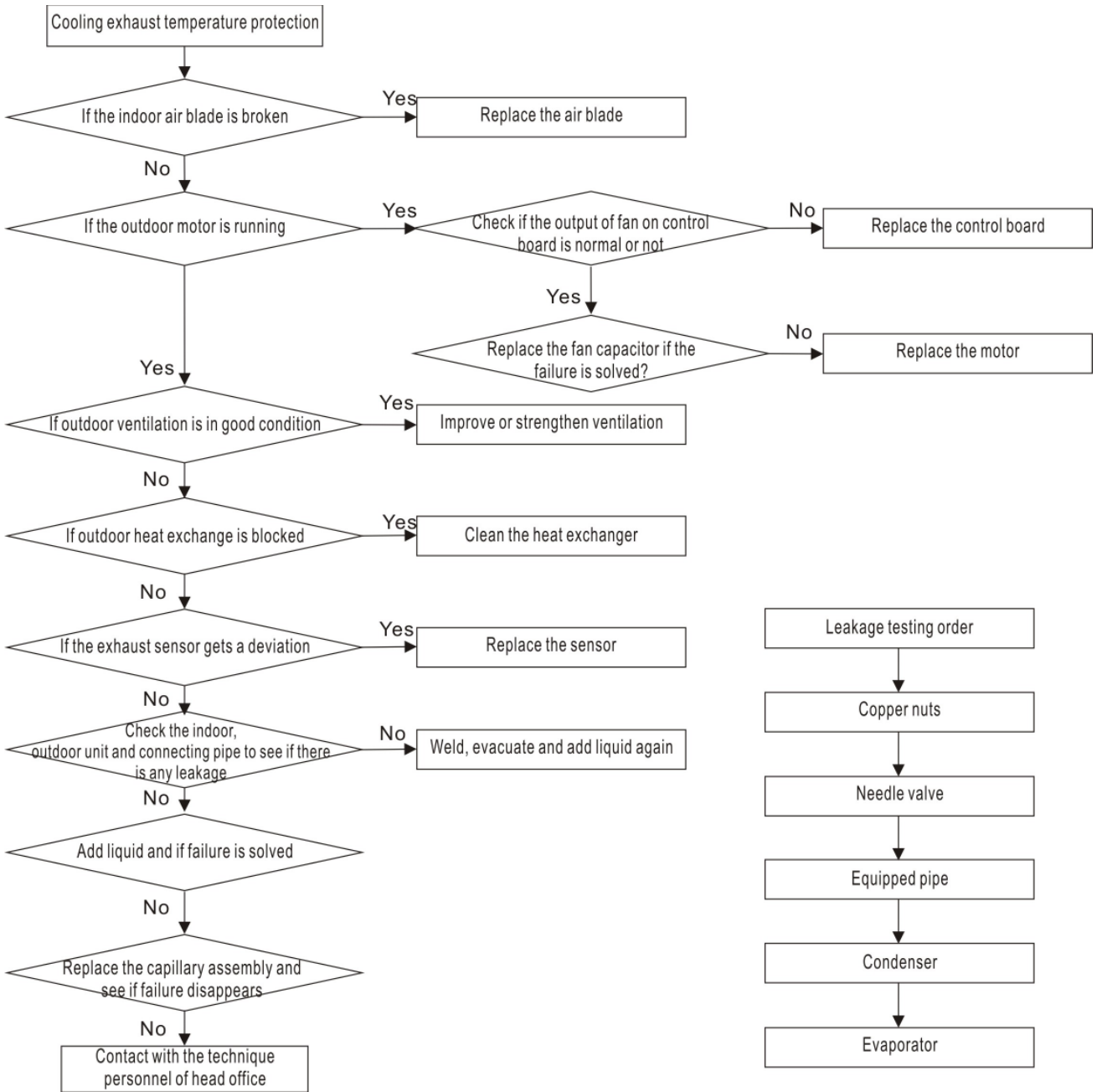

Heating exhaust temperature protection

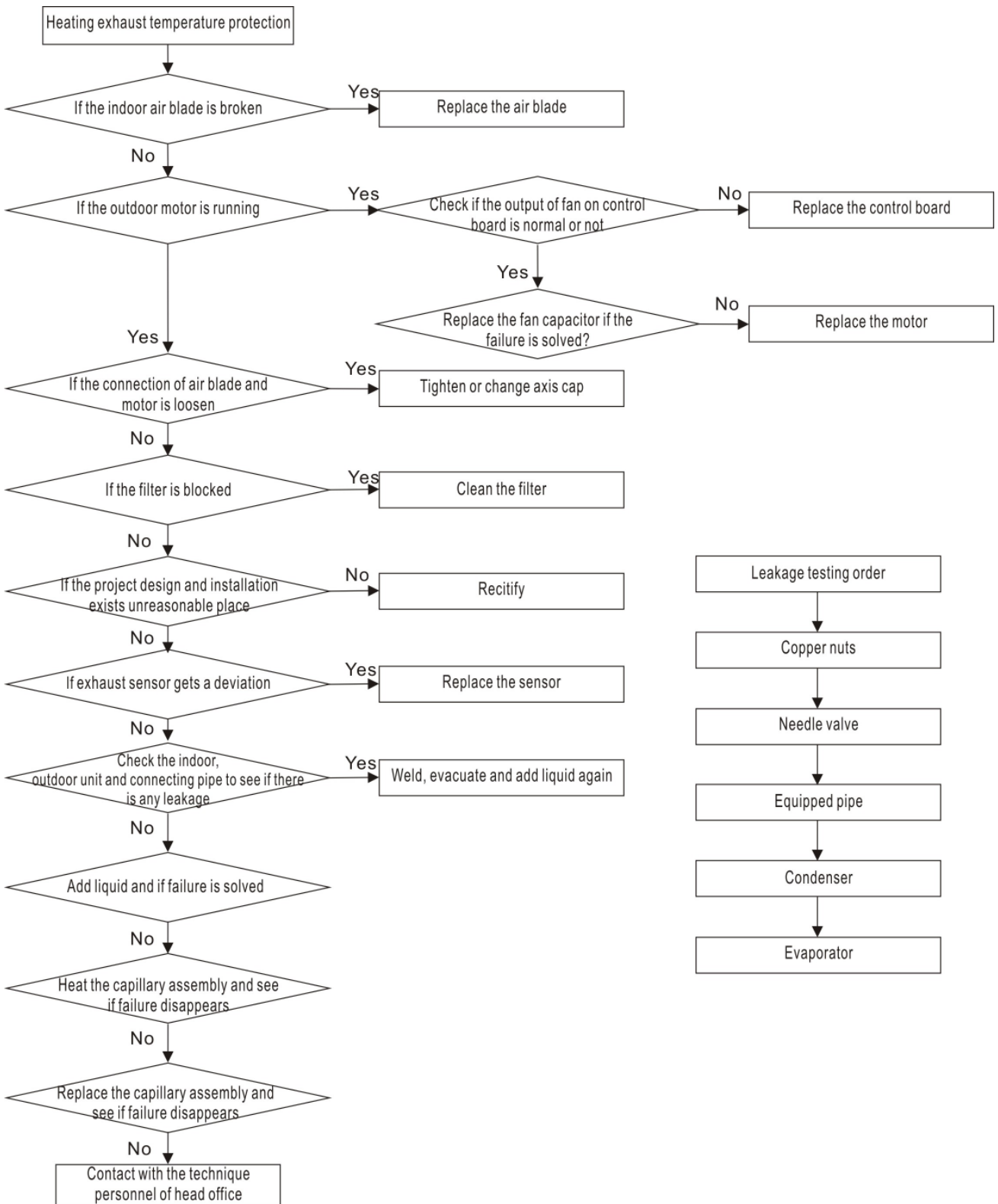

2.6 [E1] four way valve failure protection

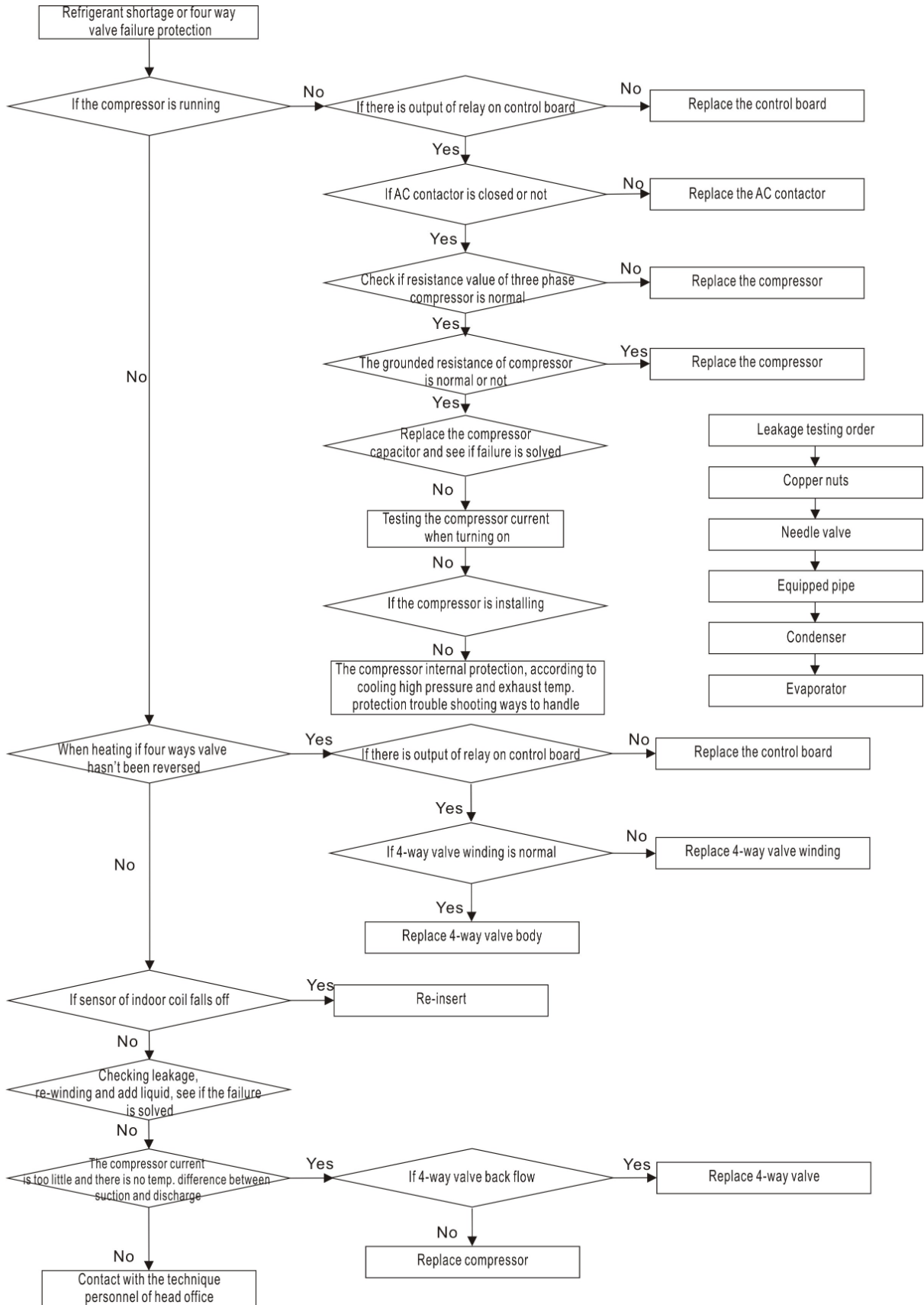

2.7 Sensor failure protection

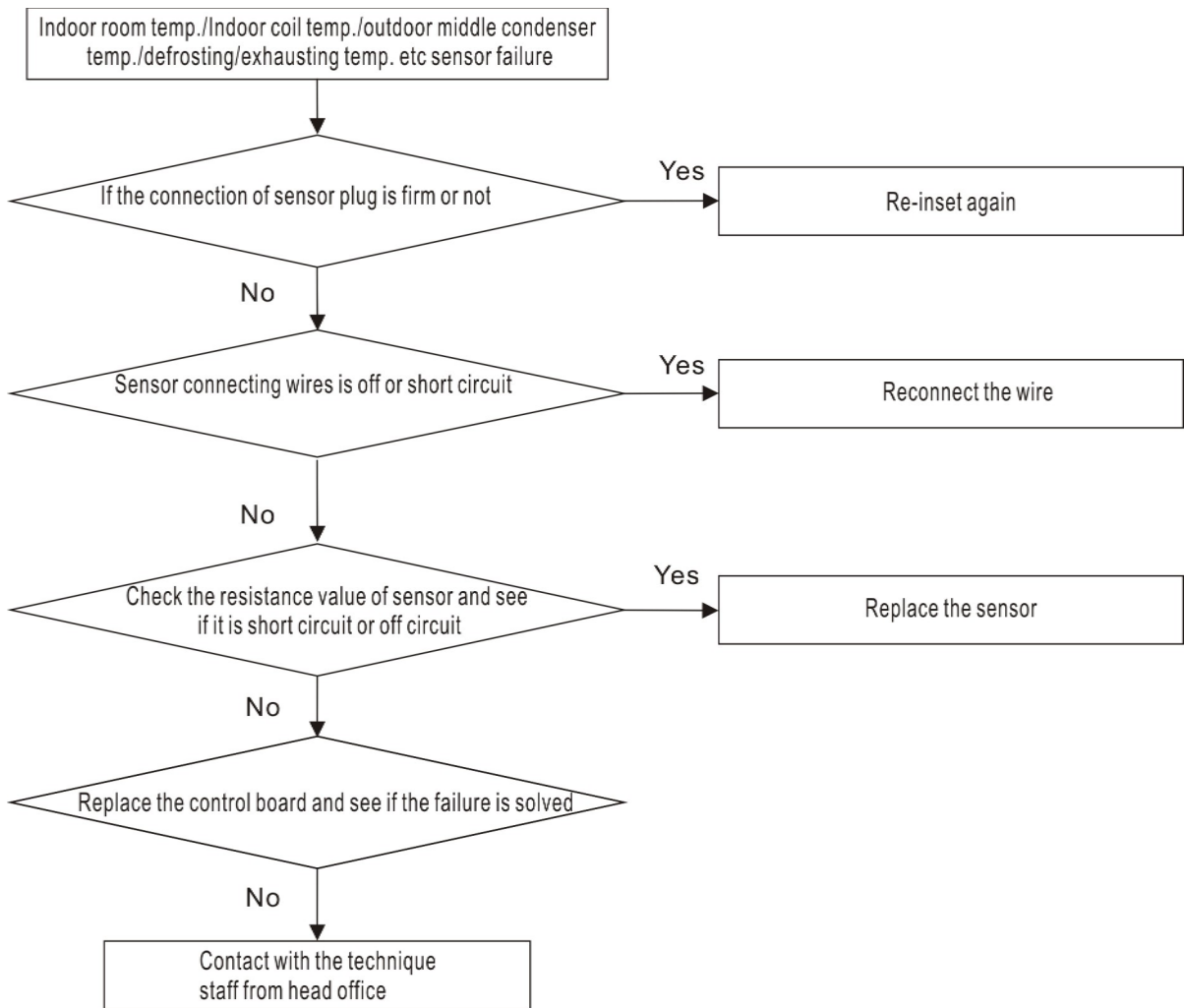



Technology leads Intelligent life

NINGBO AUX ELECTRIC CO.,LTD

Web:[Http://auxcac.cn](http://auxcac.cn)

Tel:+86-574-88220564

E-mail:auxcac@mail.auxgroup.com

Add: NO. 1166 North Mingguang Road, Jiangshan, Ningbo, Zhejinag, PR. China

The above designs and specifications are subject to charge without prior notice. Final specifications please refer to latest technical specification provided by sales representative. 201810 *Technical Support Department*